

THIS DRAWING IS UNPUBLISHED. RELEASED FOR PUBLICATION 2005
 © COPYRIGHT 2005 BY TYCO ELECTRONICS CORPORATION. ALL RIGHTS RESERVED.

LOC	DIST	REVISIONS					
		P	LTR	DESCRIPTION	DATE	DWN	APVD
A1	-						

Matrize in Kombination mit Ergocrimp Basishandzange PN 539635-1 verwenden
 Use die in combination with Ergocrimp basis hand tool PN 539635-1

Matrize im Karton mit Bedienungsanleitung 411-18336 verpackt
 Die packed in a cardboard with instruction sheet 411-18336

3-1579021-7	1	4-0744011-2	Instruction Sheet	Bedienungsanleitung	6
	1	0-0519024-2	Nut M4 DIN 985	Mutter M4 DIN 985	5
	1	1-0519151-3	Screw M4x25	Schraube M4x25	4
	1	1-0519151-1	Screw M4x16	Schraube M4x16	3
	1	8-1579015-2	Locator Assembly	Drahtanschlag	2
	1	7-1579015-8	Contact Locator	Kontaktpositionierer	1
	QTY Stck	PN	Description	Benennung	Pos.

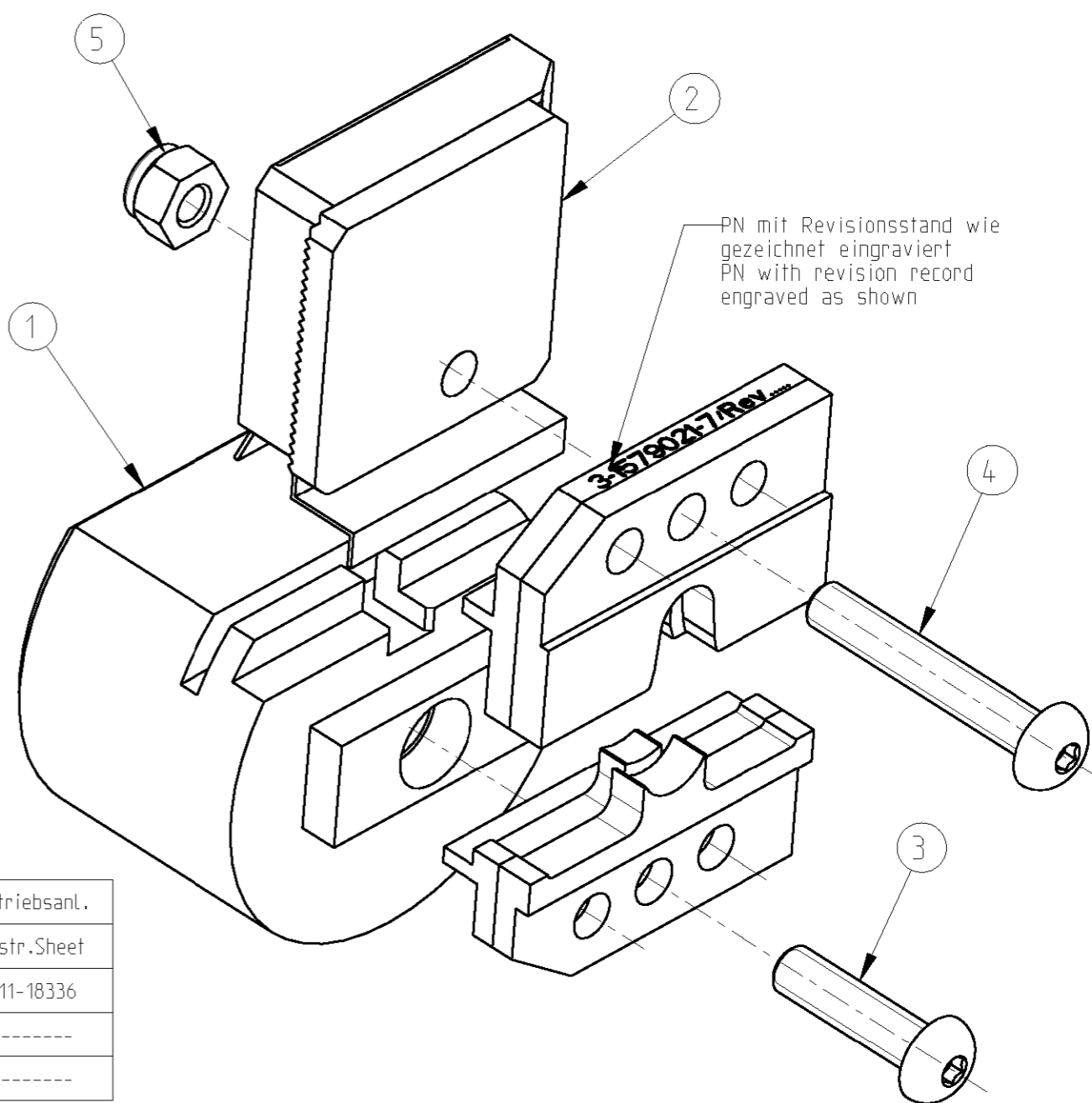

Kontakt	DGB (mm ²)	Drahtcrimp / Wire Crimp		Isolationscrimp/Insulationcrimp		Isol.∅	Betriebsanl.
Contact	Wire Range	Hoehe/Height mm	Breite/Width mm	Hoehe/Height mm	Breite/Width mm	Ins.Range	Instr.Sheet
1241419	6.0	2.58 ±0.05	4.06 F	6.9 max.	6.86 0	4.3 max.	411-18336
-----	-----	-----	-----	-----	-----	-----	-----
-----	-----	-----	-----	-----	-----	-----	-----

<small>THIS DRAWING IS A CONTROLLED DOCUMENT FOR TYCO ELECTRONICS CORPORATION IT IS SUBJECT TO CHANGE AND THE CONTROLLING ENGINEERING ORGANIZATION SHOULD BE CONTACTED FOR THE LATEST REVISION.</small>		DWN Ch.Witt 05SEP2005 CHK - APVD - PRODUCT SPEC - APPLICATION SPEC - WEIGHT -	tyco Electronics tyco Electronics AMP GmbH D - 64625 Bensheim
DIMENSIONS: mm 	TOLERANCES UNLESS OTHERWISE SPECIFIED: 0 PLC ± 1 PLC ± 2 PLC ± 3 PLC ± 4 PLC ± ANGLES ±1° MATERIAL - FINISH -	NAME ERGOCRIMP DIE SET FOR MCP 6.3 / 4.8K Ergocrimp Matrize fuer MCP 6.3 / 4.8K	RESTRICTED TO -
SIZE A3 CAGE CODE 00779 DRAWING NO. C-3-1579021-7		SCALE 5:1 SHEET 1 OF 1 REV A	