

Technical Data – OV100M

Product description

- Premium quality privacy film
- Anti-glare
- Anti-bacterial
- Anti-scratch

Construction

- Surface protection tape (PET)
- Anti-glare hard coating
- PET film
- Blind louver
- PET film
- UV hard coating

Application

- Protection of confidential data for ATM, LCD Monitor, Notebook, Kiosk, Tablet PC, etc.

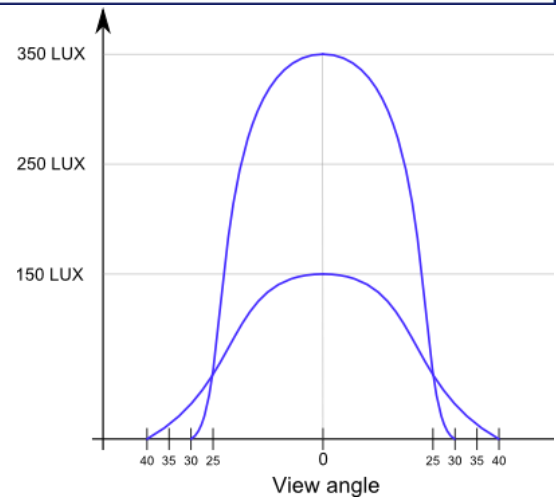
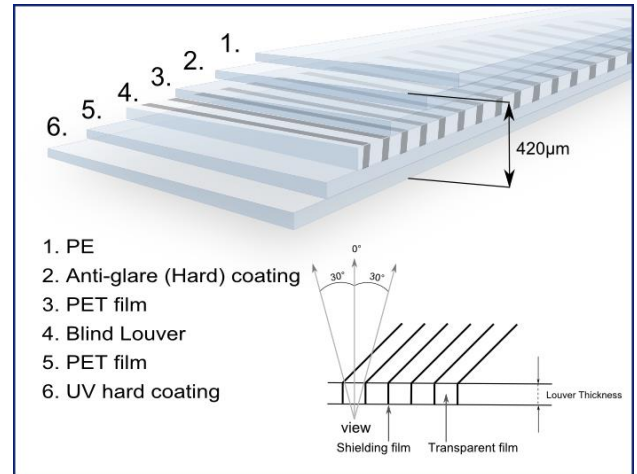

Technical data

Item	Unit		Spec.		Test method
Total thickness	µm	Inch	420±50	0.017±0.002	ASTM D3652
Transmittance	%	-	60±5	-	-
Left view angle	Degree	-	30±5	-	250Lux Standard
Right view angle	Degree	-	30±5	-	250Lux Standard
UV reduction	%	-	95±4	-	-
Temperature test	°C	°F	-20~80	-4~176	-

Note

Unless stated otherwise all values given are average. All of the tapes in our range should be thoroughly tested on the substrates in the particular application they are intended for. Hi-Bond Tapes Ltd. will not be responsible for product failure unless full testing has been completed. The customer has to decide on the tapes suitability for the intended application.

Quality Protection Films for Mobile Devices

1 Crucible Road, Phoenix Parkway, Corby, Northamptonshire NN17 5TS
 Telephone: +44 (0)1536 260660 Fax: +44 (0)1536 260044

email: sales@clear-diamond.co.uk
 www.clear-diamond.com

Company Registration No. 3985595



MEMBER
 GERMAN-BRITISH
 CHAMBER OF INDUSTRY & COMMERCE