



A2F

Ex db I/IIC, Ex eb I/IIC, Ex ta IIIC, Ex nR IIC

COMPRESSION GLAND for Single or Multi-Core Unarmoured Cable

Features and Benefits

- Passes the IECEx / UKEX / ATEX 100% pull test, so no additional cable clamping is required.
- For indoor, outdoor, Group I, II, III, Zone 1, 2, 20, 21 and 22 hazardous areas.
- Fitted with a specially formulated elastomeric displacement seal, giving superior cable retention, explosion protection and IP rating.
- Precision manufactured from high-quality brass (Marine Grade Electroless Nickel Plated™) available in aluminium or stainless steel 316/316L on request. (Note: Aluminium is not suitable for Group I applications.)
- Supplied with a thread sealing gasket (parallel threads only).



Technical Data

| | |
|--------------------------|---|
| Type: | A2F |
| Gland Material: | Brass (Marine Grade Electroless Nickel Plated™), Aluminium or Stainless Steel 316/316L |
| Seal Material: | Standard Thermoset Elastomer or Extreme Temperature Seals |
| Sealing Gasket Material: | HDPE, Nylon 66 or PTFE |
| Cable Type: | Single or Multi-Core Unarmoured |
| Sealing Area: | Outer Sheath |
| Optional Accessories: | Adaptor, Reducer, Earth Tag, Locknut, Serrated Washer and Shroud |
| Note: | The installer should ensure that the materials are suitable for the installation environment. |

Standards and Certifications

| | |
|------------------------------------|--|
| Equipment Protection Levels: | IECEX/INMETRO: Ex db eb I Mb, Ex db eb IIC Gb, Ex nR IIC Gc, Ex ta IIIC Da ATEX/UKEX: Ⓢ I M2, Ⓢ II 2/3 G, Ex db eb I Mb, Ex db eb IIC Gb, Ex nR IIC Gc, Ex ta IIIC Da CCC: Ex db IIC Gb, Ex eb IIC Gb, Ex ta IIIC Da |
| Continuous Operating Temp: | Standard Seals: -60°C to +95°C /100°C (HDPE/ Nylon Sealing Gasket) Extreme Temp. Seals: -60°C to +160°C (PTFE Sealing Gasket) |
| Conformance: | Standard: Certificate: |
| IEC/BS EN | IEC/BS EN 62444 CML 14CA364 |
| IECEX | IEC 60079 Part 0, 1, 7, 15, 31 IECEX TSA 23.0026 |
| ATEX | EN 60079 Part 0, 1, 7, 31 CML 20ATEX1026 EN 60079 Part 0, 15 CML 22ATEX4116 |
| UKEX | BS EN 60079 Part 0, 1, 7, 31 CML 21UKEX1013 BS EN 60079 Part 0, 15 CML 22UKEX4117 |
| INMETRO (Brazil) | ABNT NBR IEC 60079 Part 0, 1, 7, 15, 31 TÜV 24.0267 |
| CCC/CNEx (Chinese) | GB/T3836.1, 2, 3, 31-2021 CNEx 21.3389X CCC 2021312313000392 |
| SANS | SANS/IEC 60079 Part 0, 1, 7, 15, 31 MASC S/20-9022 |
| IP66/68 850m – Parallel | IEC 60529 CML 15Y728 |
| IP65/66 – Tapered | IEC 60529 |
| IP68 – Tapered and approved grease | IEC 60529 IECEX TSA 23.0026 |
| Deluge Protection | DTS-01 CML 14CA370-2 |
| Corrosion Protection | ASTM B117-11, BS EN ISO 3231 EXOVA N968667 |
| Marine ABS | IEC/EN 60079 Part 0, 1, 7, 15, 31 25-0164964-PDA |
| DNV | IEC/EN 60079 Part 0, 1, 7, 15, 31 TAE0000010 |
| ClassNK | IEC 60079 Part 0, 1, 7, 15, 31 TA25241M |

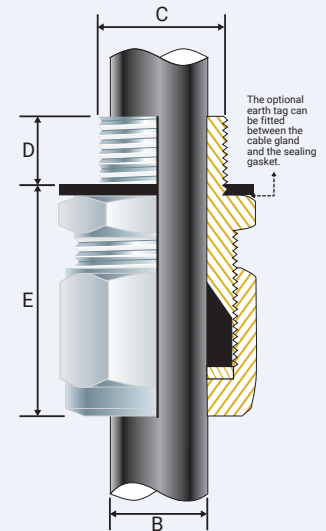

Conditions for Safe Use - X

- None.
- Note: According to IEC 60079-14, 10.6.2: An Ex d gland will only maintain Ex d integrity when used with substantially round, compact and filled cable. If not a CCG VORTEX® barrier gland should be used.

| Product Code | Material | Gland Size Ref | Metric Entry Thread | | NPT Entry Thread | | Cable Detail | | Maximum Length 'E' | Hexagonal Detail | | Installation Torque Value Nm |
|--------------|-----------------|----------------|---------------------|---------|------------------|---------|--------------|---------|--------------------|------------------|------------|------------------------------|
| | | | 'C' | Min 'D' | 'C' | Min 'D' | Min 'B' | Max 'B' | | Max 'Flats' | Max 'Crns' | |
| 50260 | Brass | 00-20ss | M20x1.5 | 15 | 1/2/3/4 | 15 | 3.0 | 8.5 | 25.0 | 24.0 | 27.0 | 32.5 |
| 50261 | Brass | 0-20s | M20x1.5 | 15 | 1/2/3/4 | 15 | 7.0 | 12.0 | 25.0 | 24.0 | 27.0 | 32.5 |
| 50262 | Brass | 1-20 | M20x1.5 | 15 | 1/2/3/4 | 15 | 11.0 | 15.0 | 30.0 | 27.0 | 30.0 | 32.5 |
| 50263 | Brass | 2-25 | M25x1.5 | 15 | 3/4/1 | 15/19 | 15.0 | 20.0 | 30.0 | 35.0 | 39.0 | 47.5 |
| 50264 | Stainless Steel | 00-20ss | M20x1.5 | 15 | 1/2/3/4 | 15 | 3.0 | 8.5 | 25.0 | 24.0 | 27.0 | 32.5 |
| 50265 | Stainless Steel | 0-20s | M20x1.5 | 15 | 1/2/3/4 | 15 | 7.0 | 12.0 | 25.0 | 24.0 | 27.0 | 32.5 |
| 50266 | Stainless Steel | 1-20 | M20x1.5 | 15 | 1/2/3/4 | 15 | 11.0 | 15.0 | 30.0 | 27.0 | 30.0 | 32.5 |

All dimensions except NPT are in mm. Intermediate thread sizes are available on request. NPT threads should be tightened 'wrench tight'

CCG reserves the right to make alterations to the technical data, dimensions, designs and products available without notice. The illustrations cannot be considered binding. Please contact Moflash for assistance.

A2F-GH090126MF

A2F COMPRESSION GLAND

ENCLOSURES AND EQUIPMENT TO WHICH CABLE GLANDS ARE FITTED:-

- Must be made from materials which are compatible with the cable gland materials.
- Have a sealing area around the cable gland entry point with a surface roughness <math>< Ra 6.3 \mu m</math>.
- Have entries that are perpendicular to the enclosure face in the area where the cable gland will seal to within 2.5°.
- Are sealed using the supplied sealing gasket (parallel threads) or by fully tightening into a threaded entry (tapered threads). Note that for tapered threads the IP rating can be improved to IP68 with the use of a suitable thread sealant.

MUST HAVE THREADED ENTRIES

- The same thread size as the cable gland. (Thread adapters should be used to correct

any mismatch).

- With a thread tolerance of metric class '6H' or equivalent.
- Where the thread length is a minimum of 10mm for Ex d applications or 3mm for all other applications

OR CLEARANCE HOLES (not Ex d)

- Where the hole size is the thread nominal size with a tolerance of +0.1 to +0.7mm. (e.g. the clearance hole for an M20 thread will have a diameter between 20.1mm and 20.7mm).
- Through material that is between 1mm and 12mm thick. (Thicker materials can be accommodated using glands with extended entry threads.)

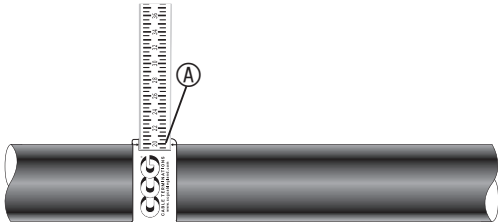

1. For accurate sizing, use a CCG Dimension Tape (A) on the outer cable sheath.

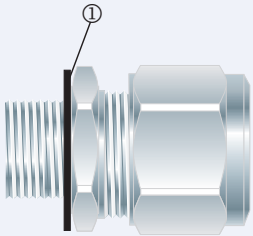

2. To maintain IP66/68, ensure the gasket (1) is in place.

If the gland has NPT entry threads fitted to a threaded entry then IP68 (2m) can be achieved by applying one of the following tested and approved grease types to the thread:- Renolit Lubrene CA700 or LX220 EP2, Renolit LC-WP2 or Moly LX2, or Dow Corning 4 Electrical Compound.

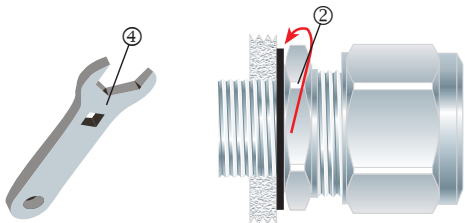

3. Screw the inner (2) into the apparatus. Tighten the inner (2) to the installation torque using a CCG Spanner (4).

Alternative installation through an unthreaded entry.

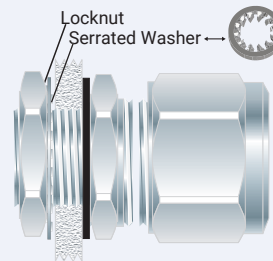

If the apparatus is unthreaded use a locknut.

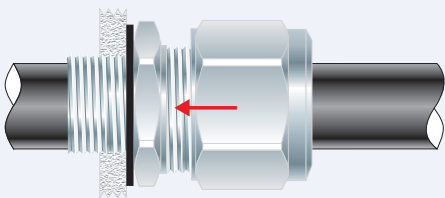

4. Pass the cable end through the gland assembly.

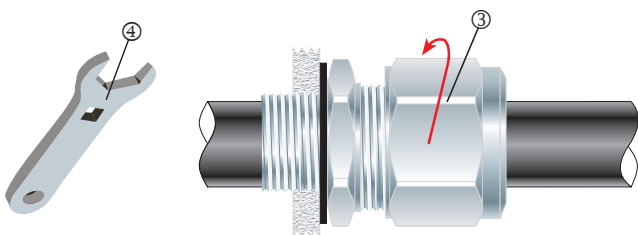

5. Tighten the outer nut (3) to the installation torque using a CCG Spanner (4) to produce a seal and grip on the cable.