

NOTE

All numerical values are in metric units. Dimensions are in millimeters, and unless otherwise specified, dimensions have a tolerance of ± 0.13 and angles have a tolerance of $\pm 2^\circ$. Figures and illustrations are for identification only and are not drawn to scale.

1. INTRODUCTION

This specification covers the requirements for application of the AMP* Z-PACK 2mm FB (Futurebus+) receptacles and pin headers for printed circuit (pc) board applications. The connectors have in-row and row-to-row centerline spacing of 2mm. They are available in either 4- or 5-row configurations.

The connectors use an open pin field construction (no ground planes) for high signal density and require minimal pc board space. The receptacles are right-angle configurations and the pin headers are both vertical and right-angle configurations; both are available with either solder tine or press-fit compliant pin contacts. Accessories and their identifying features are described and shown in Section 3 of this specification.

When corresponding with AMP personnel, use the terminology provided on this specification to help facilitate your inquiry for information. Basic terms and features of components are provided in Figure 1.

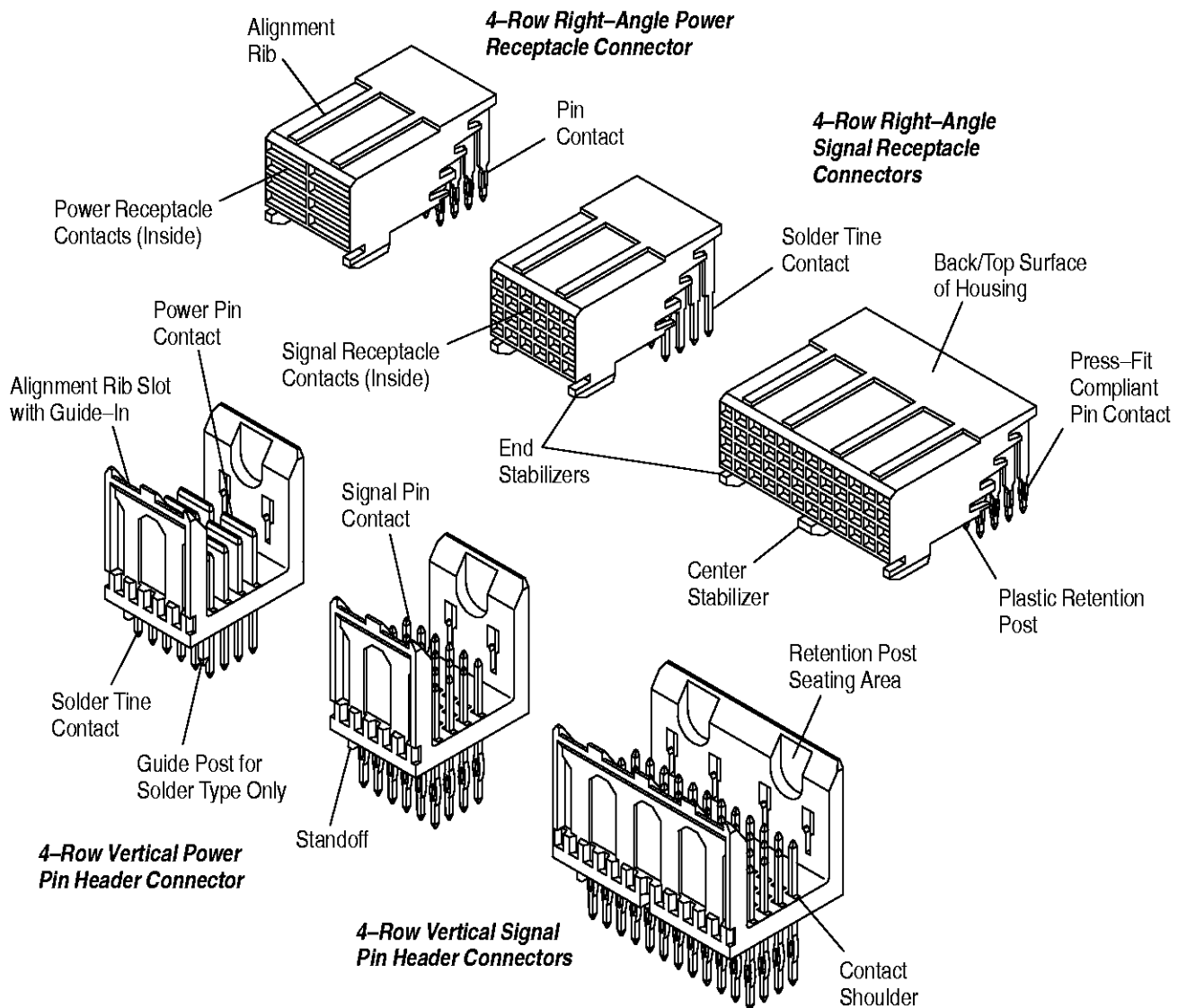

Figure 1 (cont'd)

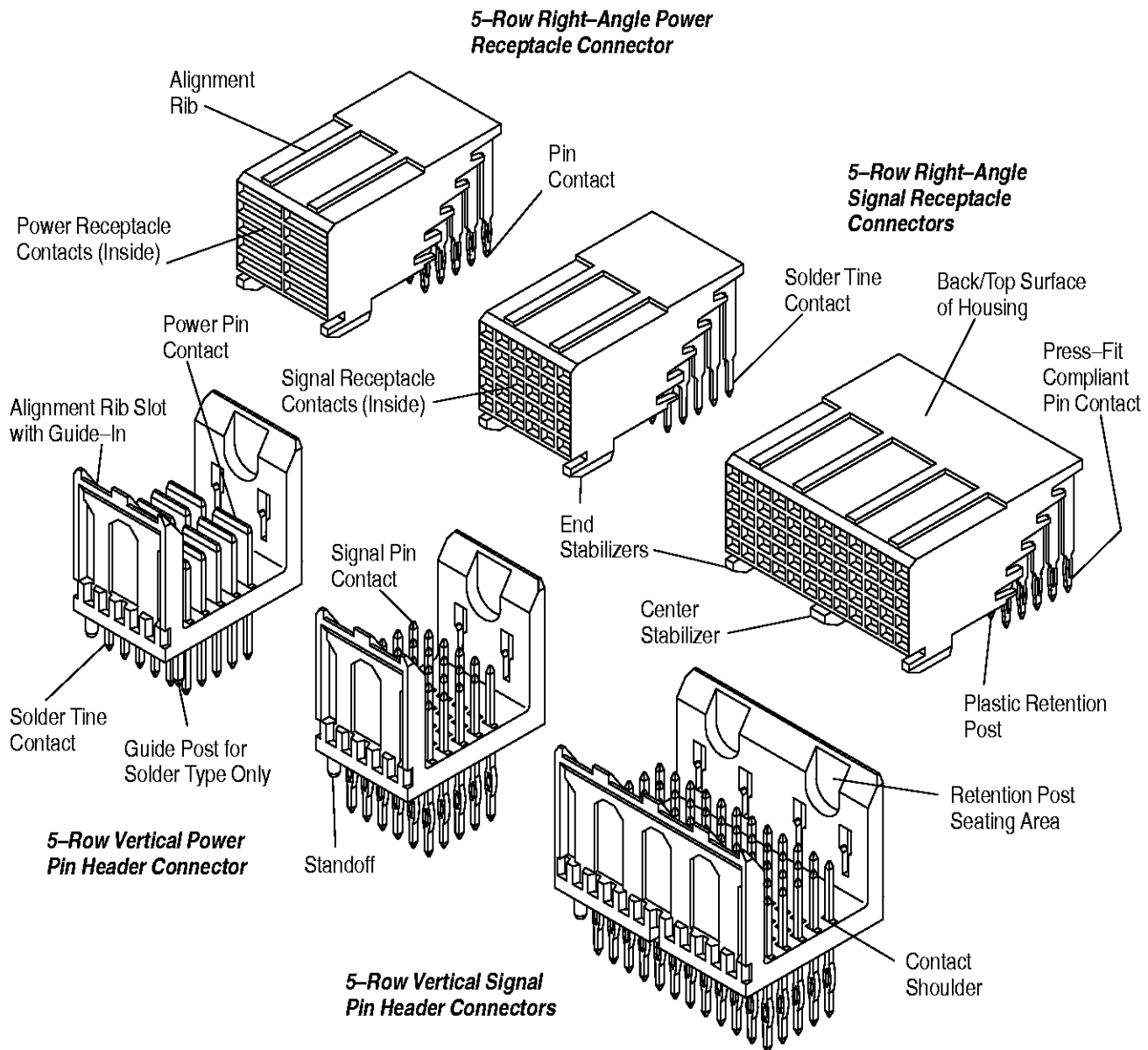

Figure 1 (end)

2. REFERENCE MATERIAL

2.1. Revision Summary

This paragraph is reserved for a revision summary of the most recent additions and changes made to this specification which include the following:

Per EC: 0990-0677-98

- Update specification to current format and application requirements
- Add 5-row connectors and related information
- Remove references to metal retention clips
- Add new documentation to Paragraph 2.6
- Add new pc board layouts for 5-row connectors
- Change art in Figure 10
- Add new tooling information in the table in Figure 12

2.2. Customer Assistance

Reference Part Number 536507 and Product Code 1830 are representative numbers of AMP Z-PACK 2mm FB Receptacle and Pin Header Connectors. Use of these numbers will identify the product line and expedite your inquiries through an AMP service network established to help you obtain product and tooling information. Such information can be obtained through a local AMP Representative (Field Sales Engineer, Field Applications Engineer, etc.) or, after purchase, by calling the Tooling Assistance Center or AMP FAX/Product Information number at the bottom of page 1.

2.3. Drawings

AMP Customer Drawings for specific products are available from the service network. The information contained in Customer Drawings takes priority if there is a conflict with this specification or with any other technical documentation supplied by AMP Incorporated.

2.4. Bulletin

AMP Corporate Bulletin 401-52 is available from the service network. This bulletin provides information on various flux types and characteristics along with the commercial designation and flux removal procedures. A checklist is attached to the bulletin as required for information on soldering problems.

2.5. Specifications

AMP Product Specification 108-1441 covers test and performance requirements.

2.6. Instructional Material

The following list includes available AMP instruction sheets (408-series) that provide assembly procedures for product, operation, maintenance and repair of tooling, as well as setup and operation procedures of applicators; and customer manuals (409-series) that provides setup, operation, and maintenance of AMP machines.

<u>Document Number</u>	<u>Document Title</u>
408-4038	PC Board Support Fixtures 679980-1, -2 for AMP Z-PACK 2mm FB (Futurebus) and 2mm HM Receptacle Tooling
408-4157	AMP Vertical Power Contact Header Connector Seating Tool 58512-[] (4-Row)
408-4250	AMP Vertical Signal Contact Header Connector Seating Tool 318860-[] (5-Row)
408-4488	AMP Vertical Power Contact Header Connector Seating Tool 1214224-[] (5-Row)
408-6927	Design Recommendations for PC Board Support Fixture
408-9910	AMP Vertical Signal Contact Header Connector Seating Tools 58511-[] (4-Row)
408-9979	Pin Repair Kit 354687-1
409-5567	AMP 10/20-Ton H-Frame Power Unit 803880-6
409-5626	AMP SM-3 Machines 814700-[]

3. REQUIREMENTS

3.1. Storage and Chemical Exposure Limitations

A. Storage

Connectors are packaged and shipped in protective anti-static tubes. To prevent damage to the housing and contact tines, connectors should remain in tubes until ready for use. They should be stored at normal room temperatures with low humidity, and used on a first in, first out basis.

B. Chemical Exposure Limitations

Do not store connectors near any chemicals listed, as they may cause stress corrosion cracking in the components.

Alkalies	Ammonia	Citrates	Phosphates	Citrates	Sulfur Compounds
Amines	Carbonates	Nitrites	Sulfur	Nitrites	Tartrates

3.2. Connector Features

A. Materials

All Z-PACK 2mm FB Connector Housings are constructed of high-temperature thermoplastic. The signal and power pin contacts are phosphor bronze and plated at the contact interface with gold flash over palladium-nickel. The signal receptacle contacts are copper alloy and plated at the contact interface with a gold flash over palladium-nickel. Power receptacle contacts are beryllium copper and plated at interface with a gold flash over palladium-nickel. All contacts have a nickel underplate and tin-lead tines.

B. Size

Connectors are available in three types: all-signal, all-power, and signal/power mix. The 4-row signal connectors are available in a range of 12-mm-length (24 positions) to 132-mm-length (264 positions) in increments of 12 mm. Also, the 4-row power connectors are available in 12-mm-length (8 positions) only. The 5-row signal connectors are available in a range of 12-mm-length (30 positions) to 132-mm-length (330 positions) in increments of 12 mm. Also, the 5-row power connectors are available in 12-mm-length (10 positions) only. Signal/power mix connectors are available in any configuration in a range of 24 mm to 132 mm in increments of 12 mm.

The contact type and length for each connector type is provided in Figure 2.

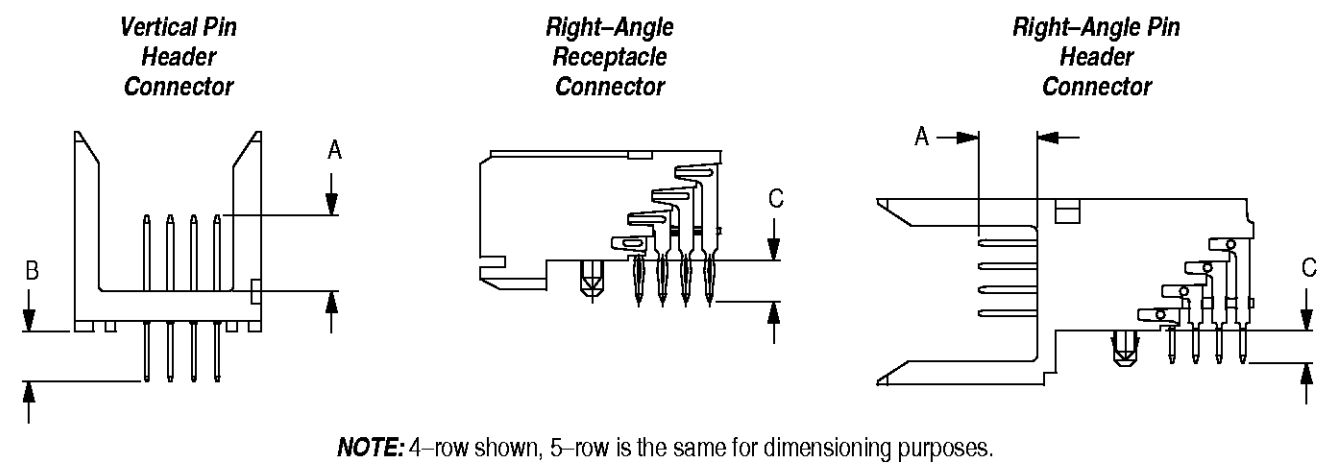

CONNECTOR		CONTACT			
TYPE	CONFIGURATION	TYPE	DIMENSION (Length)		
			A	B	C
Signal	Vertical Pin Header	Solder	5.0, 5.75, 6.5, 7.25, 8.0	3.20, 4.25	—
		Compliant Pin		4.25, 11.8, 13.6, 15.6, 17.0	
	Right-Angle Header	Solder	5.0	—	2.73
		Compliant Pin		—	3.35
	Right-Angle Receptacle	Solder	—	—	2.73, 3.53
		Compliant Pin		—	3.55
Power	Vertical Pin Header	Solder	6.5, 7.25, 8.0	3.20, 4.25,	—
		Compliant Pin		4.25	
	Right-Angle Receptacle	Solder	—	—	2.73, 3.53
		Compliant Pin		—	3.56

Figure 2

C. Guides

The pin headers have alignment slots with a guide-in that helps position the pin and socket contacts prior to engagement of the circuits. See Figure 1.

D. End-to-End Placement

The end contacts in the pin header and receptacle are one half the contact spacing distance from the ends of the housing. This design feature makes it possible to mount connectors end-to-end while maintaining the 2 mm grid pattern. When making this type of application, note that the contacts in the pin header are closer to one side of the housing to allow space for the mating pc board. The contacts and board slots must be aligned with each other when mating with a continuous pc board connector. Connectors can be mounted end-to-end within the specified dimension. See Figure 3.

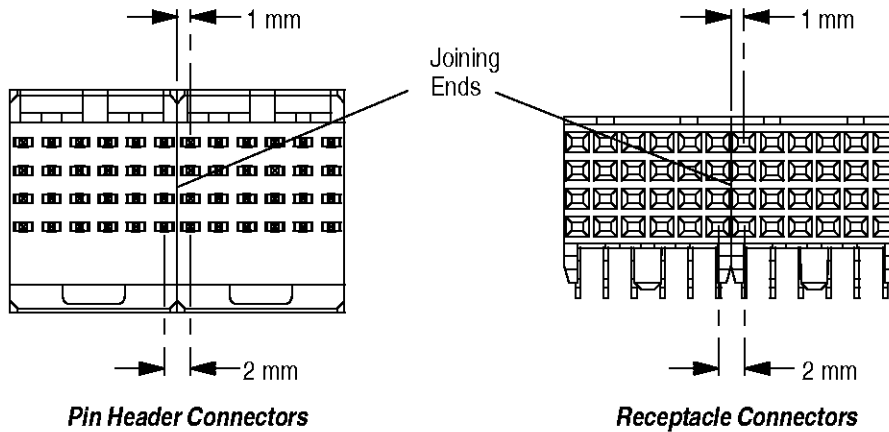

NOTE: 4-row shown, 5-row is the same for dimensioning purposes.

Figure 3

3.3. Alignment

Proper alignment is essential to ensure full engagement of mating connectors, and to ensure that contacts are not bent or otherwise damaged during mating and unmating. For tolerance limitations, see Figure 4.

NOTE: 4-row shown, 5-row is the same for dimensioning purposes.

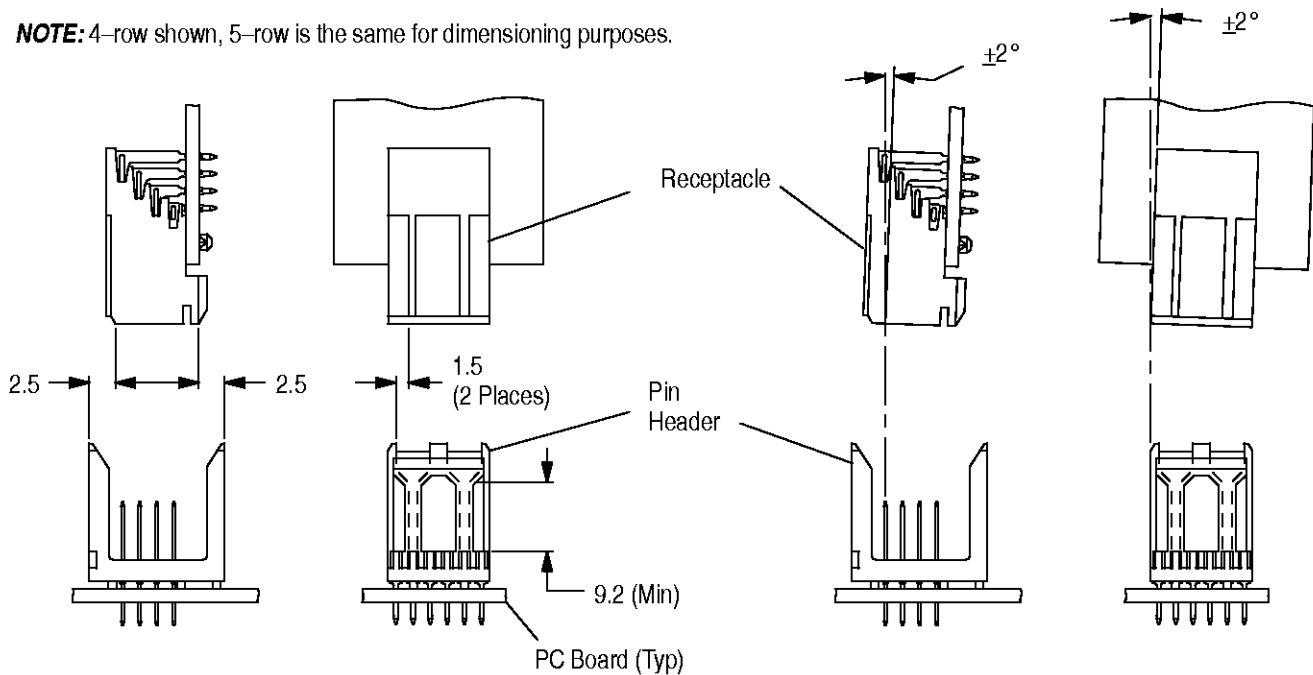
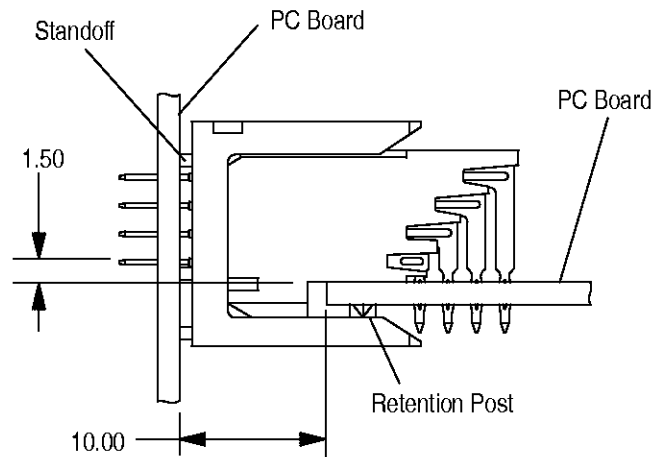

Figure 4

3.4. Mating Dimension

Full mating of connectors is necessary to ensure a good connection. The dimension from the surface of the pc board to which the pin header is mounted and the first row of contacts in the receptacle must be as shown in Figure 5.

Right Angle-to-Vertical



Right Angle-to-Right Angle

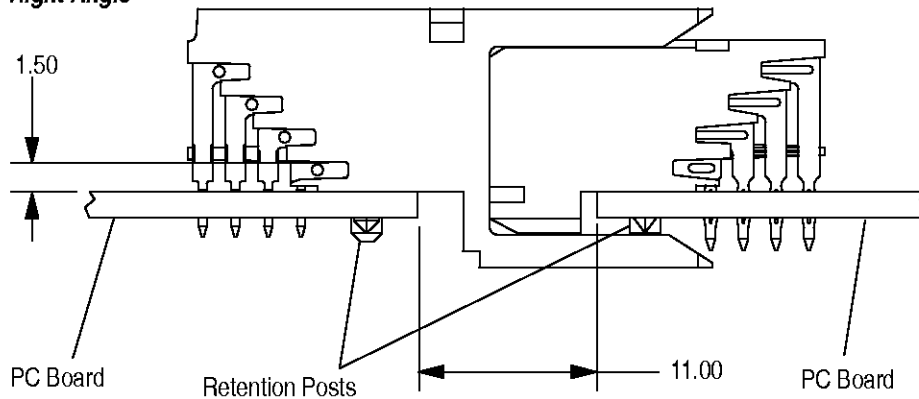

NOTE: 4-row shown, 5-row is the same for dimensioning purposes.

Figure 5

3.5. PC Board Requirements

A. PC Board Thickness

Right-angle receptacle and right-angle pin header connectors with compliant pins require a pc board with a minimum thickness of 1.30. Those with solder tines will accommodate any pc board thickness that allows the tine to protrude a minimum of 1.00 from the bottom surface of the pc board.

Vertical pin header connectors with compliant pin contacts require a pc board with a minimum thickness of 2.40. Pin header connectors with solder tines will accommodate any pc board thickness that allows the solder tines to protrude a minimum of 1.00 from the bottom surface of the pc board.

Mating pc boards for pin header connectors require a maximum allowable thickness of 2.50.

B. PC Board Circuit Pattern Layout

The pc board layout patterns for the placement of Z-PACK 2mm FB Pin Header and Receptacle Connectors are provided in Figure 6.

NOTE

For applications requiring the minimum installation force for the connector, the pc board through-hole size should favor the high end of the allowable tolerance. For applications using IR or vapor phase soldering techniques in conjunction with solder paste, through-hole size should favor the low end of the allowable tolerance to ensure optimum solder fill.

NOTE: Vertical connector pc board layouts are the same for both solder type and press fit except press fit does not have guide post holes. Right-angle connector pc board layouts are the same for both solder type and press-fit.

Recommended 4-Row PC Board Circuit Pattern Layouts (Component Side)

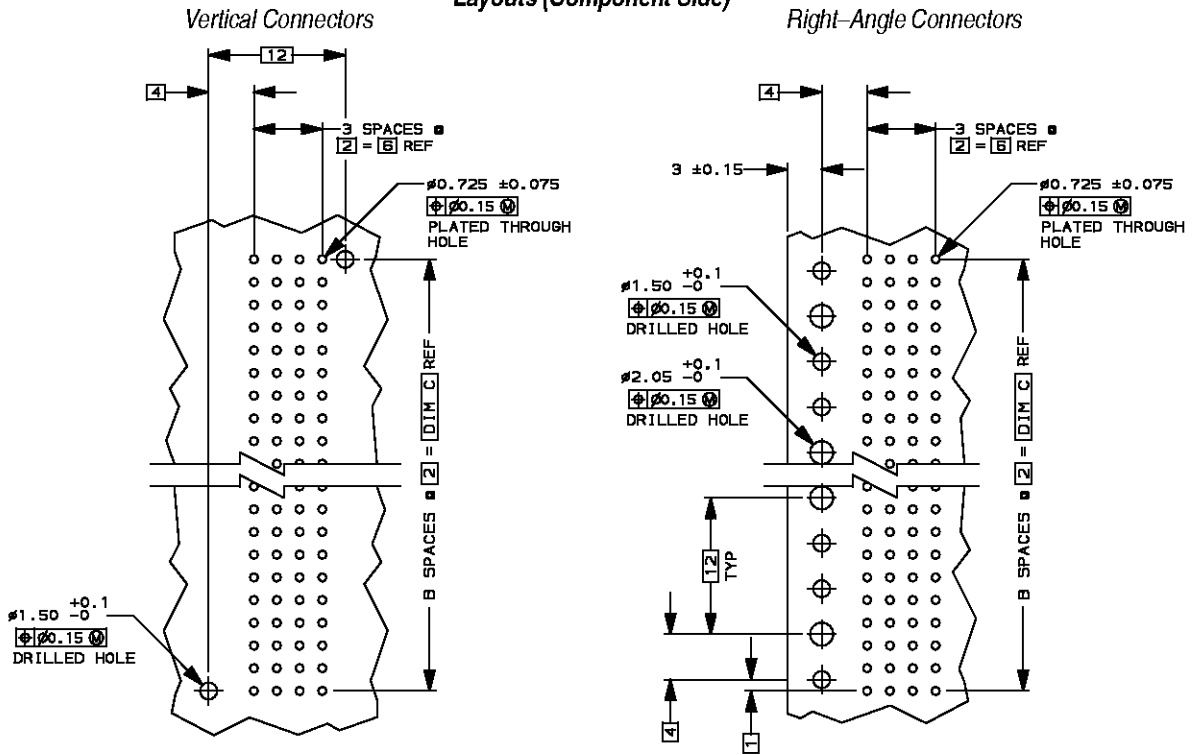

Recommended 5-Row PC Board Circuit Pattern Layouts (Component Side)

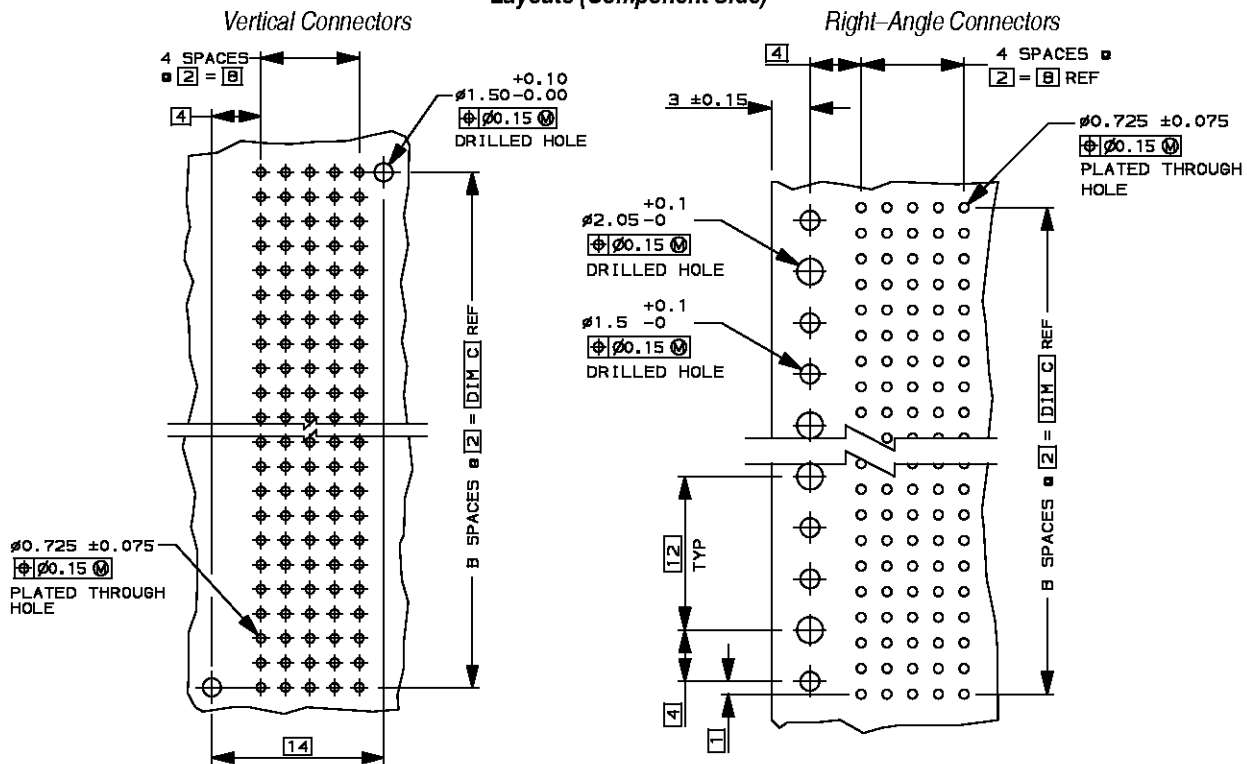
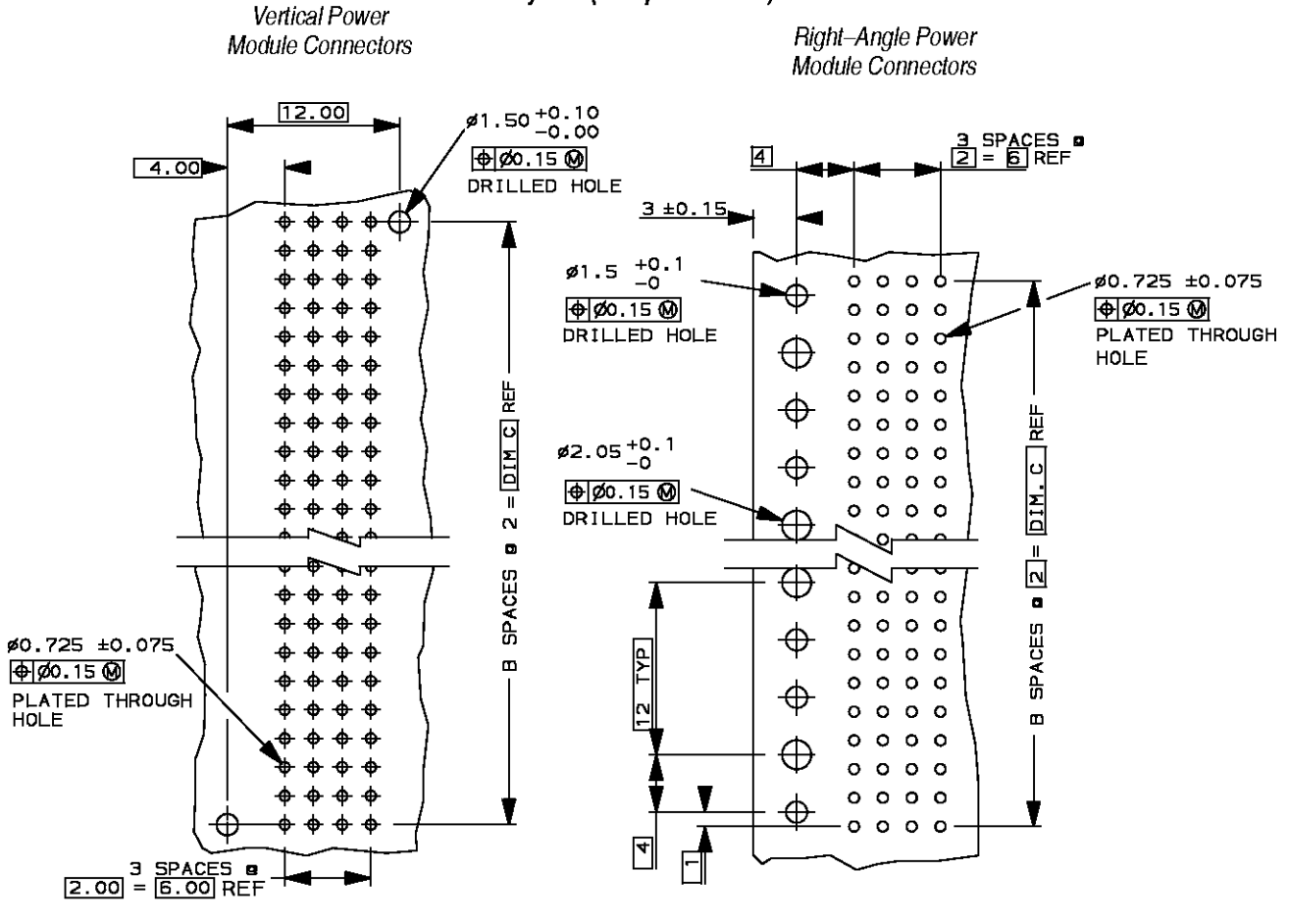

Figure 6 (cont'd)

NOTE: Vertical connector pc board layouts are the same for both solder type and press fit except press fit does not have guide post holes. Right-angle connector pc board layouts are the same for both solder type and press-fit.

Recommended 4-Row PC Board Circuit Pattern Layouts (Component Side)



Recommended 5-Row PC Board Circuit Pattern Layouts (Component Side)

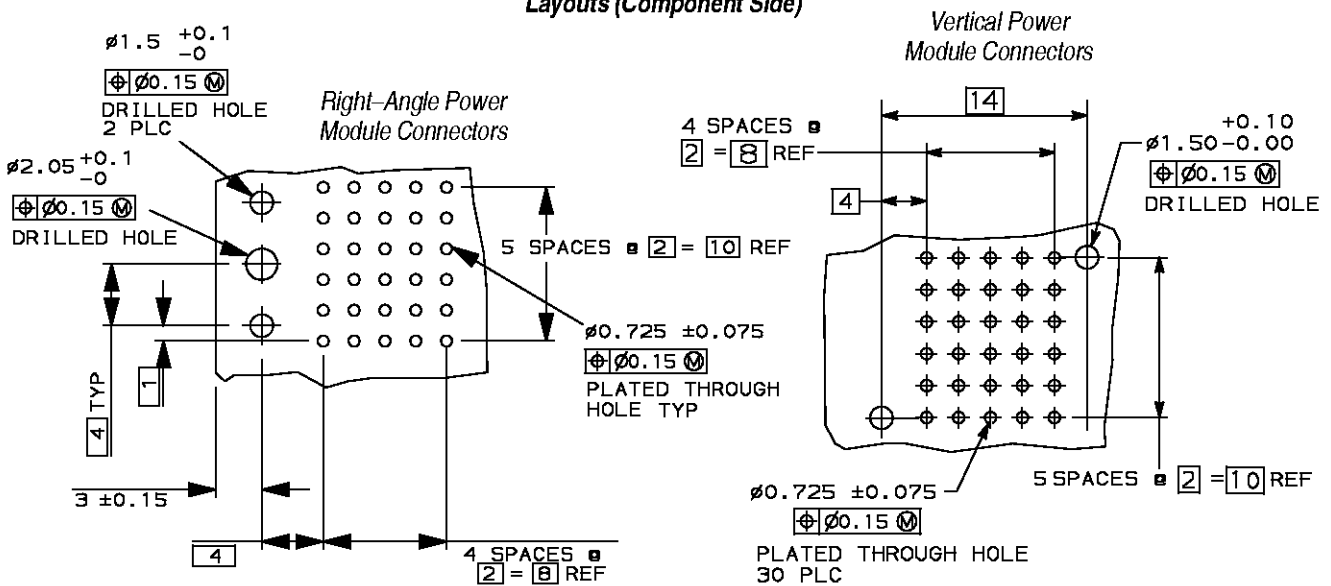

Figure 6 (cont'd)

NUMBER OF SIGNAL POSITIONS		DIMENSION B	DIMENSION C
4-ROW	5-ROW		
—	630	125	250
	540	107	214
264	330	65	130
240	300	59	118
216	270	53	106
192	240	47	94
168	210	41	82
144	180	35	70
120	150	29	58
96	120	23	46
72	90	17	34
48	60	11	22
24	30	5	10

Figure 6 (end)

C. Contact Hole Configuration

The contact holes in the pc board for all connectors must be prepared to the dimensions specified in Figure 7.

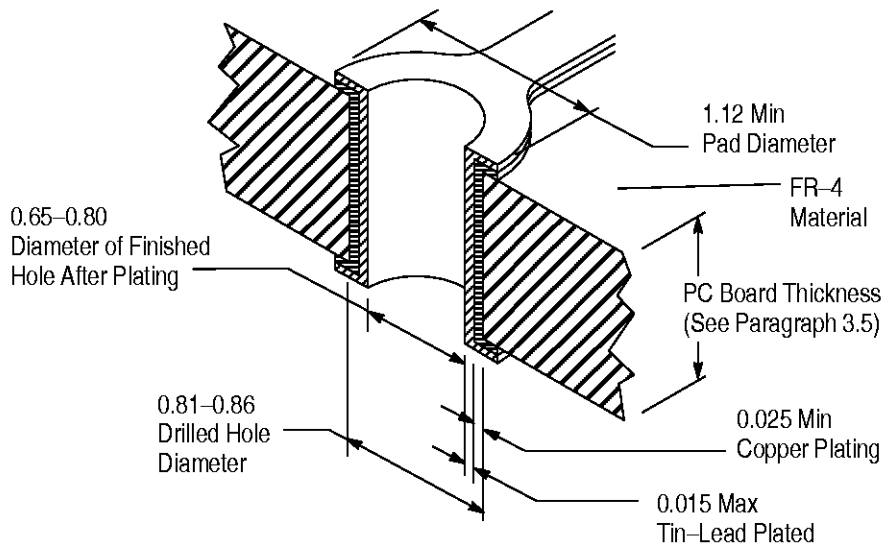

Figure 7

3.6. Special Handling

A. Initial Positioning

Prior to positioning a connector, the pc board should be placed on an appropriate board support fixture. Connectors should be gripped by the housing only and not by the contacts. When placing a connector into a pc board, all contact pins should be aligned and inserted into the pc board simultaneously to prevent twisting or bending of the contacts. If using robotic equipment, a total equipment accuracy of ± 0.13 , including the gripper and fixture tolerance and equipment repeatability, is required.

B. Seating Connectors

Seating force must be applied evenly on the connectors to prevent deformation or other damage to the contacts and housings. The standoffs must be within 0.13 of the pc board (after insertion or soldering). Refer to Paragraph 3.8.

When installing vertical pin header connectors with compliant pins, the insertion force must be simultaneously applied to the shoulder of each contact on the inside floor surface of the connector. When installing right-angle connectors with compliant contact pins, the insertion force must be evenly applied to the back/top surface of the connector housing (see Figure 1) with a force of approximately 67 N per pin.

When installing vertical pin header connectors with solder tines, the insertion force must be evenly distributed to the inside floor surface of the connector. When installing right-angle connectors with solder tines, the insertion force must be evenly applied to the back/top surface of the connector housing (See Figure 1) with a force of approximately 40 N per each 12 mm of length of the connector. Connectors will remain securely on the pc board until passed through soldering providing that they are not jarred in any manner. Tooling recommendations are covered in Section 5.

3.7. Soldering

Connectors with solder tines must be soldered to the pc board.

A. Flux Selection

The solder tines must be fluxed prior to soldering with a rosin base flux. Selection of the proper flux will depend on the type of pc board and other components mounted on the pc board. The flux must be compatible with the wave solder line, and all manufacturing and safety requirements.

DANGER

To avoid personal injury, strict attention must be given to the recommendations of the solvent manufacturer regarding toxicity and other safety requirements. Request the Material Safety Data Sheet (MSDS) from the supplier.

B. Cleaning

After soldering, removal of fluxes, residues, and activators is necessary. Consult with the supplier of the solder and flux for recommended cleaning solvents. A list of common cleaning solvents that will not affect the connectors for the time and temperature specified is provided in Figure 8.

CLEANER		TIME (Minutes)	TEMPERATURES (Maximum)	
NAME	TYPE		CELSIUS	FAHRENHEIT
Alpha 2110■	Aqueous	1	132	270
Bioact EC-7◆	Solvent	5	100	212
Carbitol●	Solvent	1	Room Ambience	
Isopropyl Alcohol	Solvent	5	100	212
Kester 5778⚡	Aqueous	5	100	212
Kester 5779⚡	Aqueous	5	100	212
Lonco 520●	Aqueous	5	100	212
Lonco 530●	Aqueous	5	100	212
Terpene Solvent	Solvent	5	100	212

■ Product of Fry's Metals, Inc. ◆ Product of Petroferm, Inc. ● Product of Union Carbide Corp. ⚡ Product of Litton Systems, Inc.

Figure 8

C. Drying

When drying cleaned assemblies and pc boards, do not exceed the temperature limitations of -55° to 125°C. Excessive temperatures may cause housing degradation.

D. Soldering Guidelines

Refer to Paragraph 2.4 for reference material bulletin that is available for establishing soldering guidelines.

3.8. Inspection

A. Solder Fillets

All solder fillets should comply to the AMP Workmanship Standard 101-21. For a typical fillet for these connectors, refer to Figure 9.

B. Housing Stand-Offs

The connector housing standoffs must be seated within the dimension shown in Figure 9 of the pc board (after insertion or soldering).

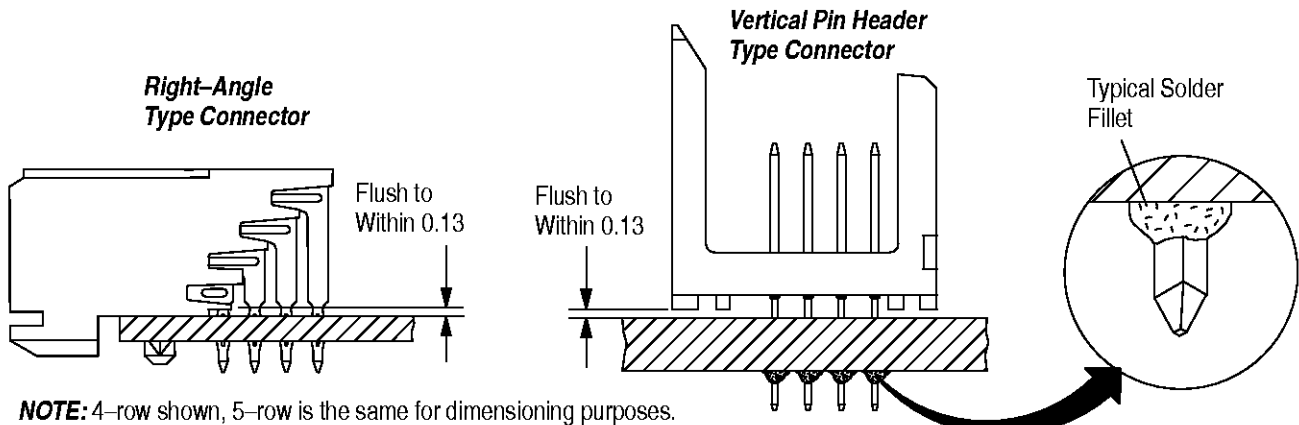

Figure 9

3.9. Repair

Damaged contacts can not be removed from receptacle housing connectors. The entire connector will have to be removed and replaced with a new one.

A. Right-Angle Receptacles with Solder Tines

Before removing the connectors from the pc board, remove solder from all solder tines by heating them and removing the solder fillet. Do NOT apply heat to the pc board, otherwise you could damage plated-through holes. After solder is removed, grip the center of the housing with a pair of pliers and pull the connector straight away from the pc board. Drill the holes with a 0.60 drill bit; then clean the holes. Insert a new connector and solder it using standard hand soldering technique. See Figure 10.

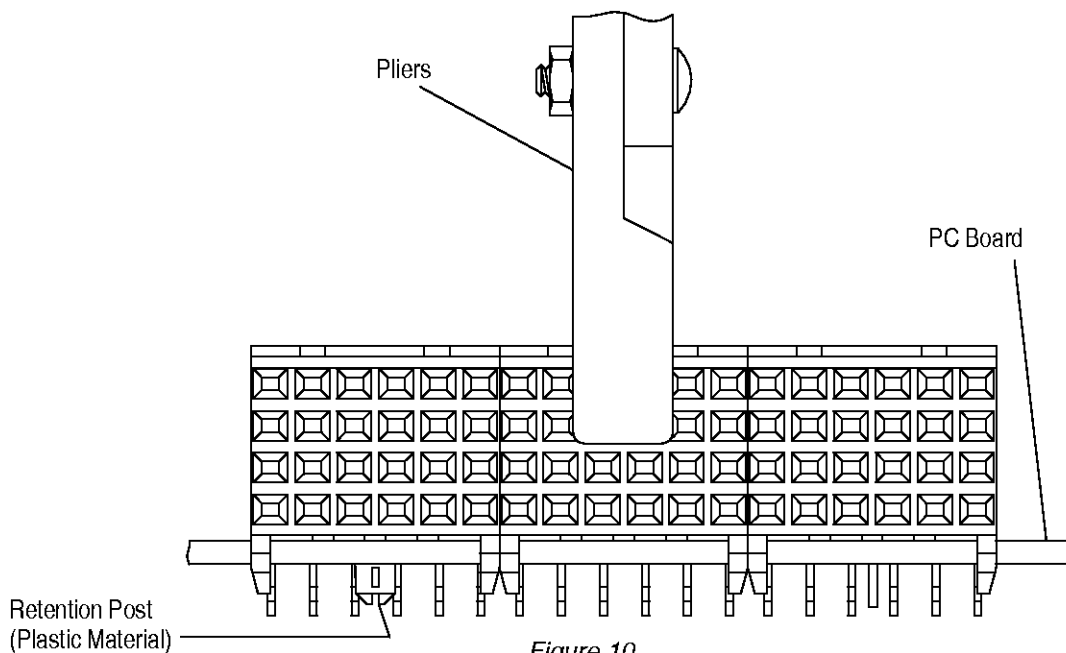

Figure 10

B. Right-Angle Connectors with Compliant Pins

Place the connector in a housing support that has a slot wide enough and deep enough to receive the full length of the housing and contacts. Make sure the tool support will not interfere with any other components on the pc board. Apply an even force simultaneously to all compliant pins with a push bar and press capable of applying 100 N per pin. See Figure 11.

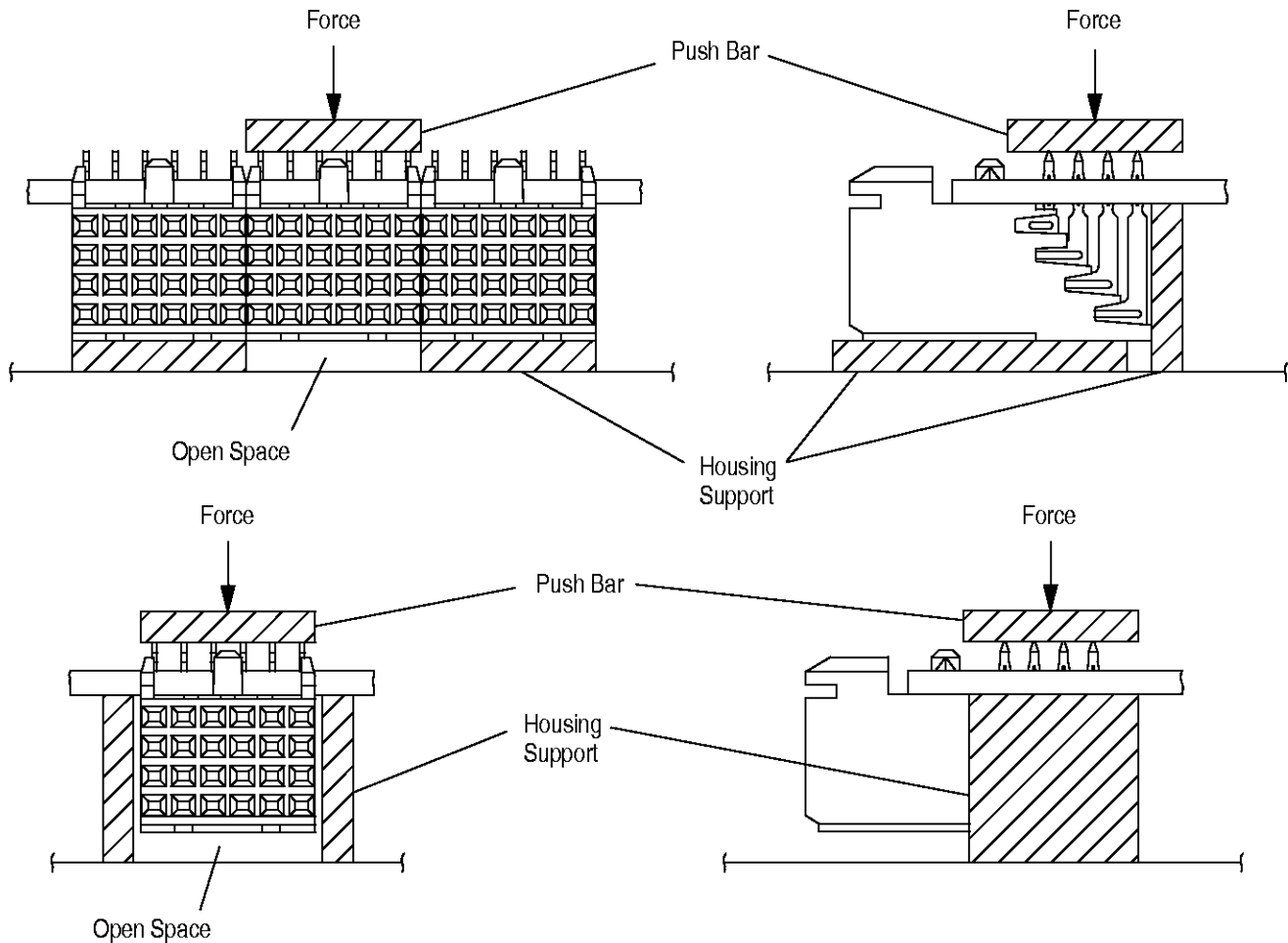

Figure 11

C. Vertical Pin Headers with Solder Tines

Individual solder tine contacts can be removed by removing the solder fillet and gripping the front of the contact with a pair of needle-nosed pliers and pulling it straight out the front of the pin header. Replace contact with a new one.

D. Vertical Pin Headers with Compliant Pins

Individual compliant pin connector contacts can be removed and replaced with a new one without removing the pin header module from the pc board. If the pin header housing is damaged, the entire connector must be removed and replaced with a new one. In either case, the pc board must be firmly supported while in-line force is applied on the contact pin. Replace contact with a new one. See Section 5 for recommended impact repair tool.

4. QUALIFICATION

These connectors meet Institute of Electrical and Electronic Engineers (IEEE), Electronic Industries Association (EIA), and International Electrotechnical Commission (IEC) specifications for printed circuit boards. AMP Z-PACK 2mm FB Connectors are component recognized by Underwriters Laboratories Inc. (UL) under File No. E28476 and certified by the Canadian Standards Association (CSA) under File No. LR7189.

5. TOOLING

AMP has existing tooling and tooling concepts for applying these connectors. Part numbers of available tools and the applicable instructional material for each is provided in Figure 12.

- **Robotic Equipment**

Robotic equipment for placement of connectors on a pc board must have a true position accuracy of 0.13 to ensure proper location and insertion of the contact pins. This includes gripper and fixture tolerances as well as equipment repeatability. It must use the connector datum surface to ensure reliable connector placement. If you need assistance in setting up prototype or production line equipment, contact AMP Tooling Engineering through your local AMP Representative or call the AMP Tooling Assistance Center number at the bottom of page 1.

- **Seating Tool**

AMP seating tools are designed to push evenly on the shoulders of the vertical pin contact and force the compliant pins into the pc board. See Figure 1.

- **Push Bar**

Commercially available bar stock with a flat surface large enough to cover the top surface of right-angle connectors and capable of exerting 67 N per pin can be used as a push bar to seat the compliant pin and solder tine connectors onto the pc board. The same type tooling can be used to remove damaged right-angle connectors from a pc board by pressing evenly on the compliant end of the contacts.

- **PC Board Support**

A pc board support must be used to prevent bowing of the pc board during insertion of the connectors. It should have a flat surface with holes or a channel large enough to receive the pins during installation.

- **Housing Support**

A housing support with sides and ends as close as possible to the receptacle housing is recommended for removing damaged receptacle connectors from pc boards.

- **Repair Tool**

A repair tool kit consisting of a spring-loaded impact tool handle assembly, a removal tip, and a replacement tip is available for removing damaged compliant pin contacts and replacing them with new ones. The housing must be supported and the contact must be free to back out of housing with a suitable housing support that will not damage housing.

NOTE

The tooling referenced in Figure 12 may be used for both compliant pin and solder type connectors.

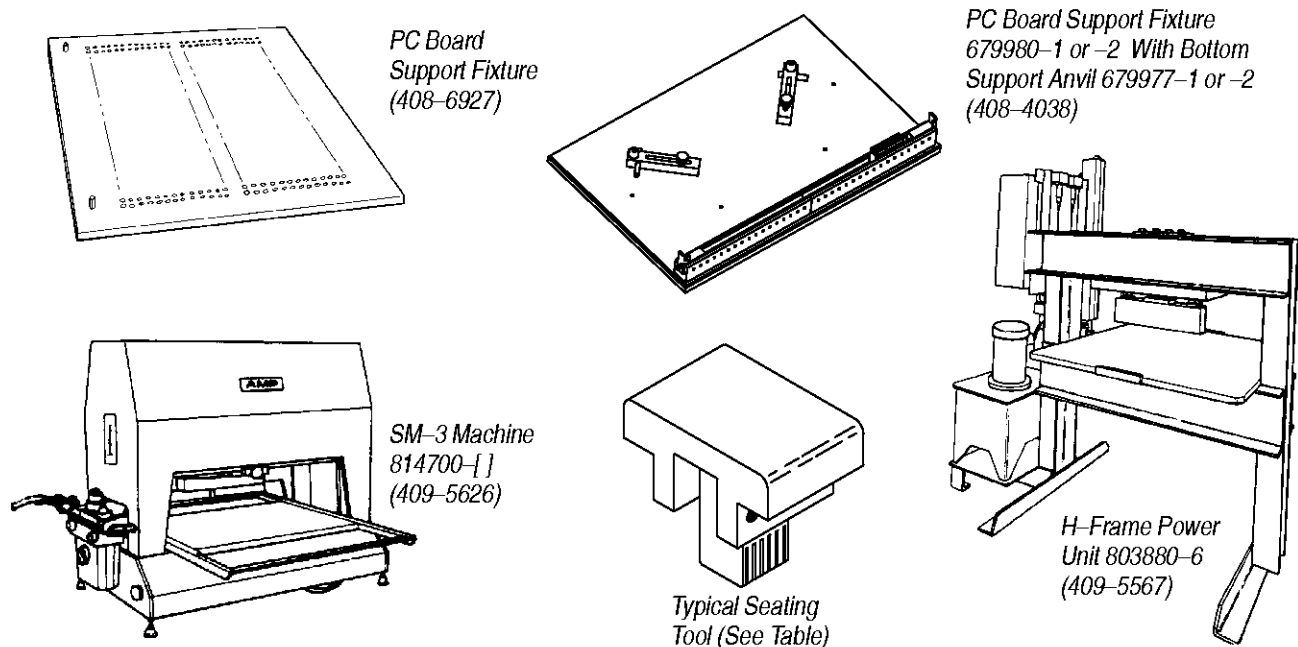
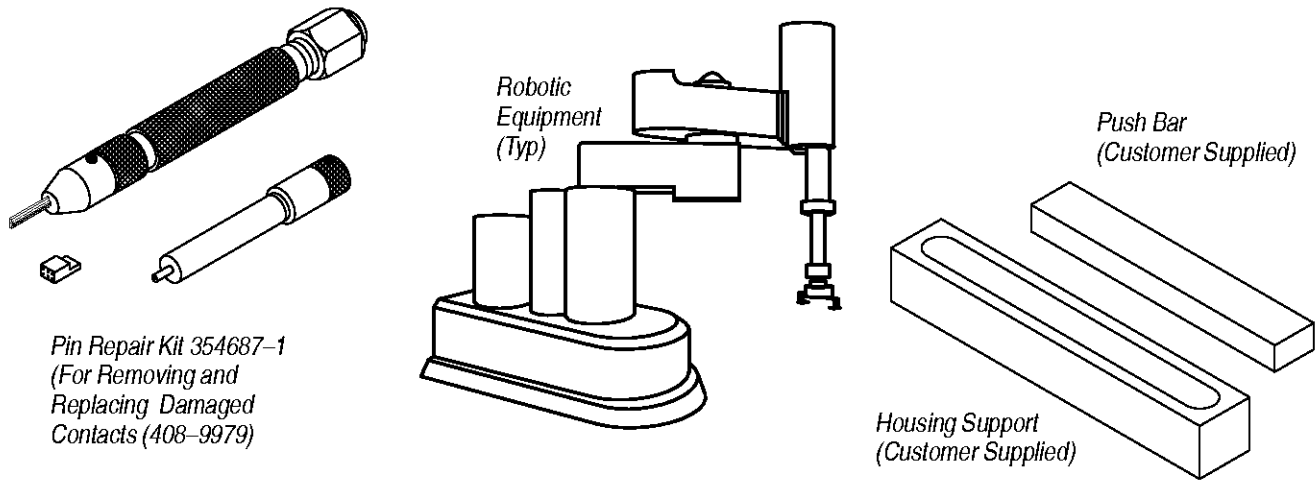

Figure 12 (cont'd)



CONN MODULE TYPE	(4-ROW)			(5-ROW)		
	POSN	SEATING TOOL (DOCUMENT)	POWER UNIT (DOCUMENT)	POSN	SEATING TOOL (DOCUMENT)	POWER UNIT (DOCUMENT)
Signal	24	58511-1 (408-9910)	803880-6 (409-5567) 814700-2 (409-5626)	30	318860-1 (408-4250)	814700-2 (409-5626)
	48	58511-2 (408-9910)		60	318860-2 (408-4250)	
	72	1-58511-4 (408-9910)		90	318860-3 (408-4250)	
	96	58511-3 (408-9910)		120	318860-4 (408-4250)	
	120	58511-6 (408-9910)		150	318860-5 (408-4250)	
	144	58511-5 (408-9910)		180	318860-6 (408-4250)	
	168	58511-7 (408-9910)		210	318860-7 (408-4250)	
	192	58511-4 (408-9910)		240	318860-8 (408-4250)	
	216	58511-8 (408-9910)		270	318860-9 (408-4250)	
	240	58511-9 (408-9910)		300	1-318860-0 (408-4250)	
	264	1-58511-0 (408-9910)	330	1-318860-1 (408-4250)		
			540	1-318860-3 (408-4250)		
			630	1-318860-2 (408-4250)		
Power	8	58512-1 (408-4157)	803880-6 (409-5567) 814700-2 (409-5626)	10	1214224-1 (408-4488)	803880-6 (409-5567) 814700-2 (409-5626)
	16	58512-2 (408-4157)				
Hybrid Signal/Power Mix	8P-96S	1-58511-7 (408-9910)	803880-6 (409-5567) 814700-2 (409-5626)	10P-30S	1-318860-4 (408-4250)	814700-2 (409-5626)
	8P-120S	1-58511-8 (408-9910)				
	8P-144S	1-58511-3 (408-9910)				
	8P-192S	1-58511-1 (408-9910)				
	8P-216S	1-58511-2 (408-9910)				
	16P-192S	1-58511-6 (408-9910)				
	16P-216S	1-58511-5 (408-9910)				

Figure 12 (end)

6. VISUAL AID

Figure 13 shows a typical application of AMP Z-PACK 2mm FB Connectors. This illustration should be used by production personnel to ensure a correctly applied product. Applications which **DO NOT** appear correct should be inspected using the information in the preceding pages of this specification and in the instructional material shipped with the product or tooling.

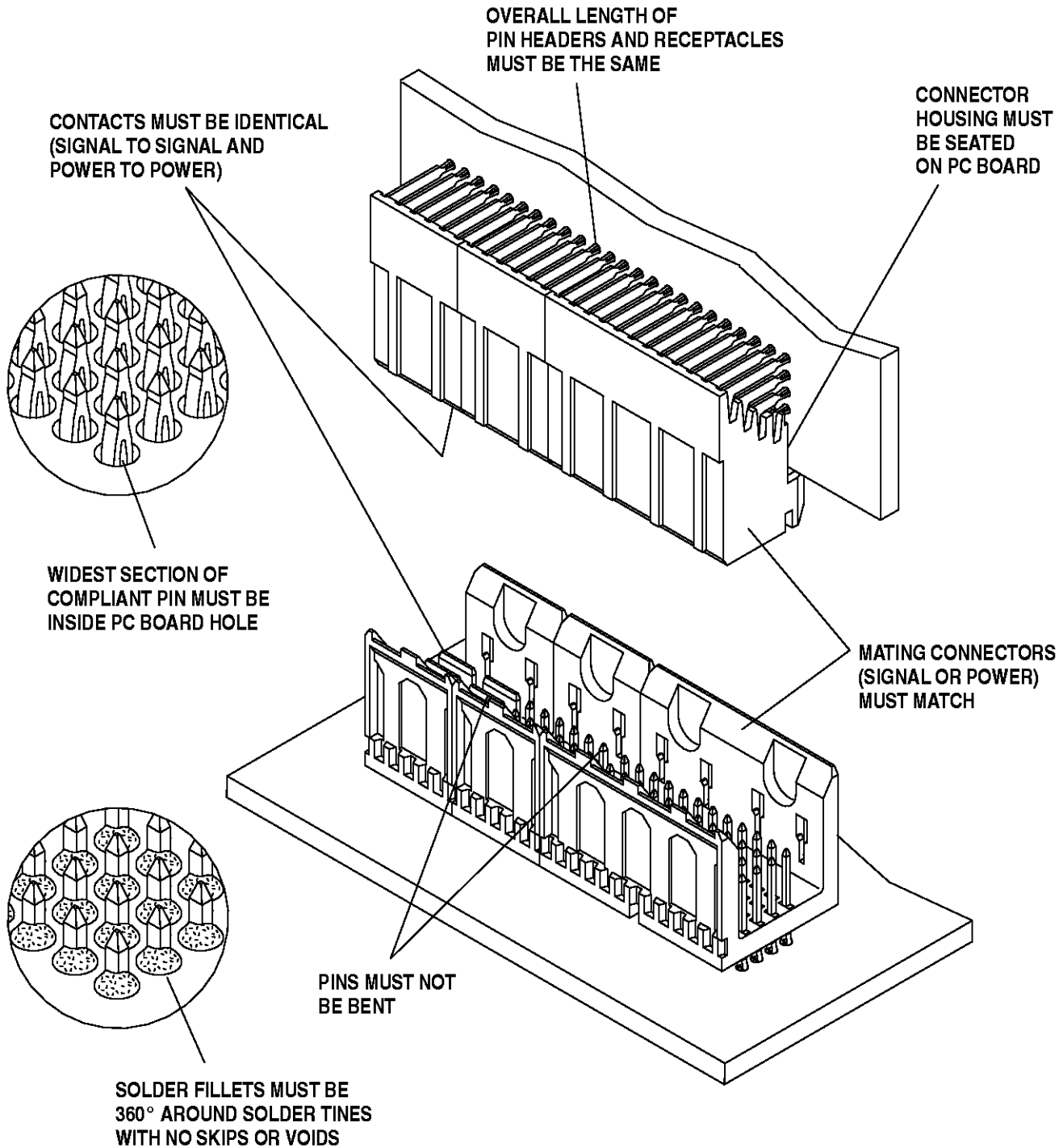
**FIGURE 13. VISUAL AID**