

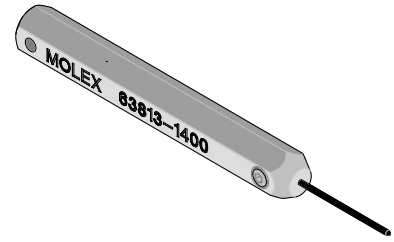

Extractor Tool

## Application Tooling Specification Sheet



Order No. 63813-1400

### FEATURES

- This tool is designed for the removal of various kinds of crimped terminals from their housings. See below.

### SCOPE

Products: See Chart below.

Terminal Series No.	Description	Housing Series No.	Terminal Order Number			
5263	2.50mm Pitch SPOX™ Wire-to-Board Crimp Terminals, 22-28 AWG	5264	08-70-1039	08-70-1040	08-70-1047	08-70-1045
			08-70-1046	39-00-0042	39-00-0043	39-00-0151
			39-00-0152	39-00-0159	39-00-0160	39-00-1167
33467	2.54mm Pitch MX64™ Female Terminals 18-22 AWG	31403, 34566, and 34576	33467-0001	33467-0002	33467-0003	33467-0004
			33467-0005	33467-0006		
33468	2.54mm Pitch MX64™ Female Terminals 18-22 AWG	31403, 34566, and 34576	33468-0001	33468-0002	33468-0003	33468-0004
			33468-0005	33468-0006		
36876	Ditto™ Male/Female Crimp Terminal 20-26 AWG	36877	36876-0001	36876-0002		
45627	2.50mm Pitch SPOX™ Male Terminals, 22-24 AWG	45626	45627-0001	45627-0002	45627-1001	
150152	MX150CE Male Terminal, 0.35-1.5mm	150149	150152-0021	150152-0022	150152-0023	150152-0041
			150152-0042	150152-0043	150152-2001	150152-2002
			150152-2003			
150153	MX150CE Female Terminals, 0.35-1.5mm	150148	150153-0021	150153-0022	150153-0023	150153-0041
			150153-0042	150153-0043	150153-2001	150153-2002
			150153-2003			

### OPERATION:

For 33467 and 33468 Terminal Series:

#### Wire Dress Cover Removal

- With connector removed from module and interface facing down, gently unlatch wire dress cover latch features.



2. With wire dress cover latch features unlatched; insert finger into wire dress cover and pull up and away from the wire bundle.



3. At this time the tie wrap should be removed from the wire bundle for easier access to the wire to be serviced.

### TPA Servicing

1. Insert a small (2.0mm maximum) flat blade screwdriver into the TPA service hole at either end of the connector and gently pry up. The TPA will stop when it reaches its pre-lock position for terminal servicing. \* Approximate TPA travel will be 3.5mm.
2. Repeat step 1. On the other end of the TPA until the TPA is sitting in its pre-lock position at both ends of the connector.

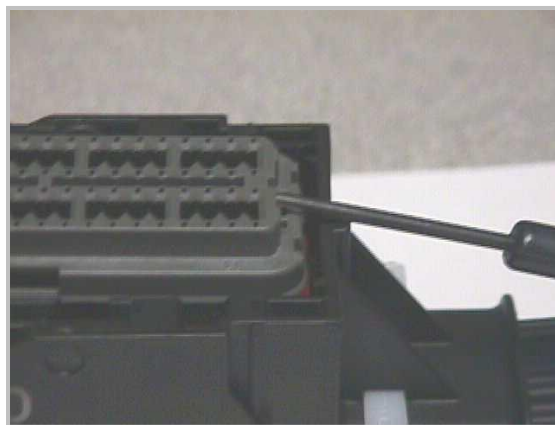
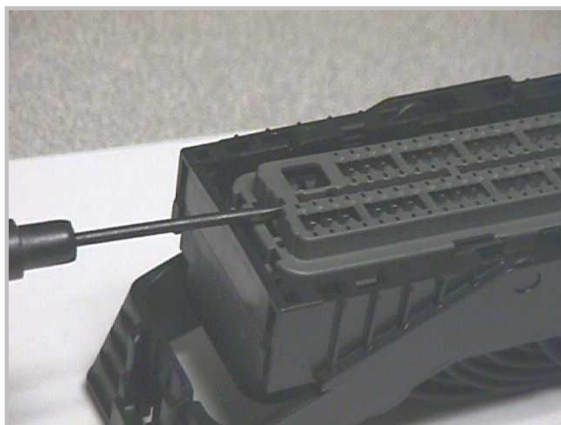

## Terminal Removal

1. Using the Molex 0.64 mm service tool (part no. 63813-1400), gently insert the tip into the terminal service hole adjacent to the terminal to be serviced. Be careful not to push the service tool into the terminal opening.

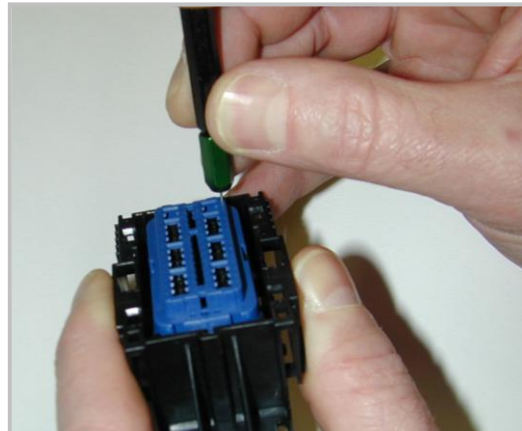

2. Once past the terminal opening, push the service tool against the terminal and push until it wedges between the terminal and the lock finger. Once the terminal lock finger is disengaged, gently pull on the wire to release the terminal. If the terminal resists, the service tool may not be fully engaged. Give the service tool a further push to ensure that it has disengaged the terminal lock finger.

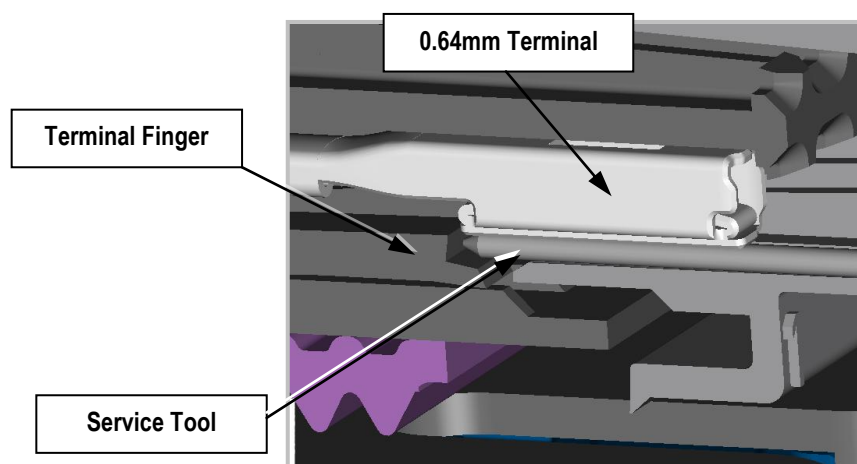
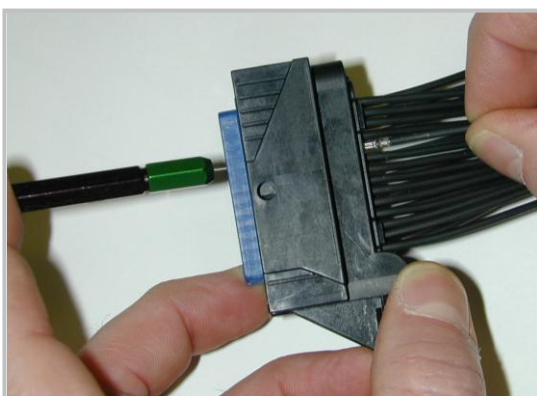

### Terminal Installation

1. With TPA still in pre-lock position, and wire dress cover removed, orient terminal to grommet cap.
2. Grip the wire no less than 1.25 inches from the terminal insulation crimp and insert through grommet cap and into connector. If resistance is encountered, retract the terminal and adjust the angle of attack. Continue inserting the terminal until it stops and locks up on the lock finger with an audible click.

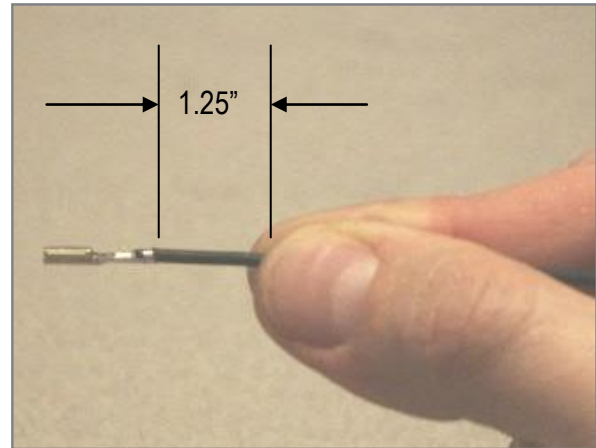

### TPA Seating (TPA pre-lock to final-lock)



1. With the terminal fully installed, the TPA can be seated into its final-lock position by applying an even force to both ends until it comes to a stop. If the TPA resists it may be detecting a partially installed terminal.
2. Pull the TPA back into its pre-lock position, check to see that your terminal is fully installed and push it further into the cavity if required. Now the TPA can be seated.

### Tie Wrap installation

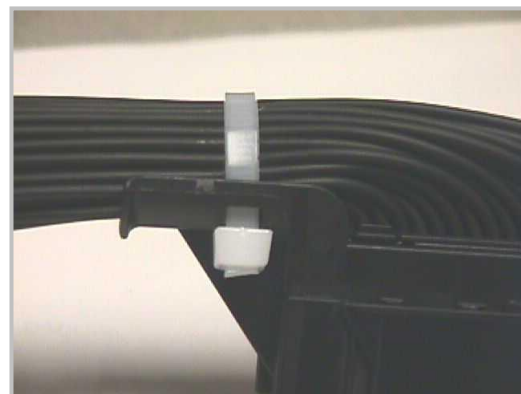
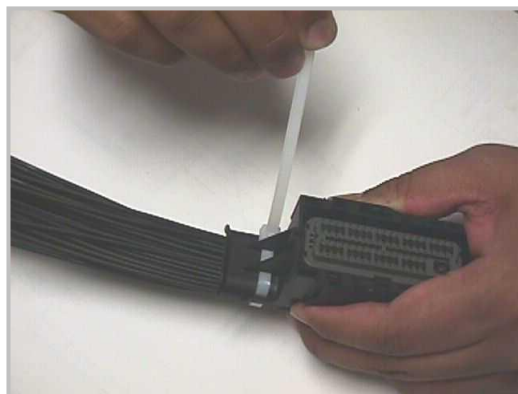

**Wire Dress Cover installation**



**For 45627-0001,45627-0002 and 5263 Terminal Series:**

**Note:** Extracted Terminal is not reusable.

1. Push the terminal forward in the arrow direction before using the Extractor Tool as shown
2. Insert the Extractor Tool into the slot on the bottom or top row of the connector housing as shown until it bottoms.
3. The extractor pin will depress the terminal locking tabs then pull the terminated wire out of the housing as shown. Wiggling the wire while pulling it out will help.

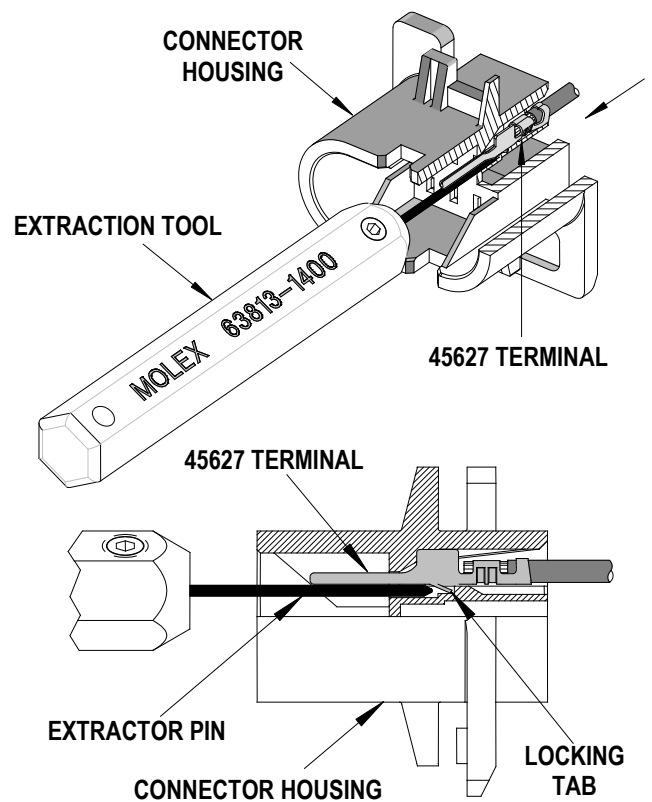
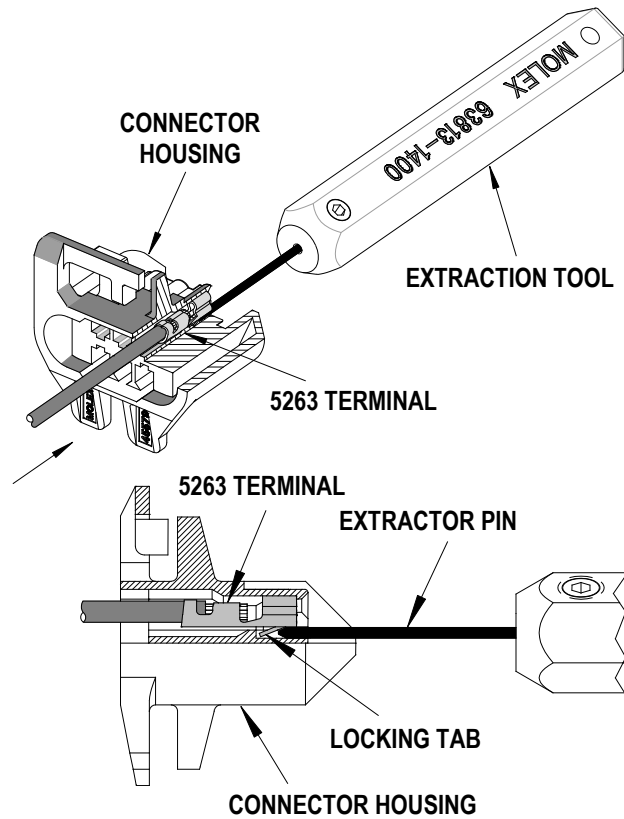

**For 36879 Terminal Series:**

*Note: Extracted Terminal is not reusable.*

1. Push the terminal forward in the arrow direction before using the Extractor Tool. See Figure 4.
2. Insert the Extractor Tool into the slot on the bottom row of the connector housing as shown until it bottoms.

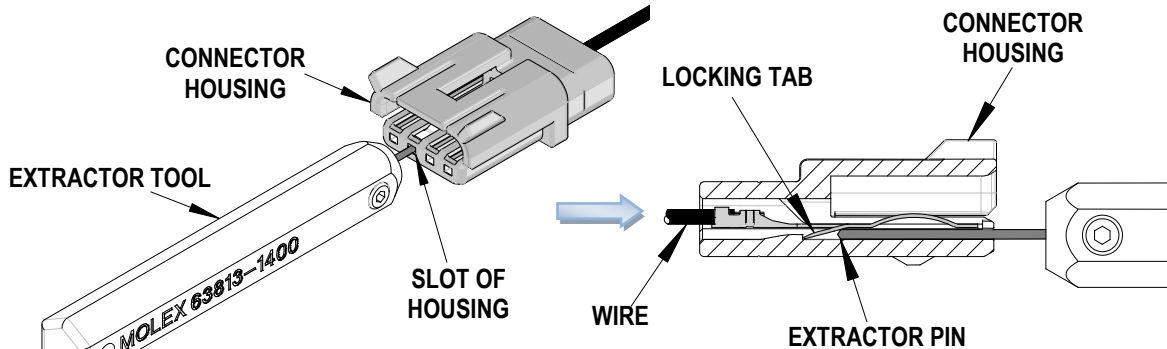

Figure 4

3. The extractor pin will depress the terminal locking tabs then pull the terminated wire out of the housing. Wiggling the wire while pulling it out will help.

**CAUTION:** This extractor tool should be used to extract the terminal only. Using it for unintended purposes may cause injury or damage to parts. Be careful not to deform the end of the terminal.

**For 150152 and 150153 Terminal Series:**

**TPA:** Before terminals can be extracted the TPA must be pulled back to its pre-lock position. Use the applicable extractor tool. See Specification Sheet ATS-638130020.

*Note: Extracted Terminal is not reusable.*

1. Push the terminal forward in the arrow direction before using the Extractor Tool. See Figure 5.
2. Insert the Extractor Tool into the hole of the TPA on the bottom row of the connector housing as shown until it stops.
3. The extractor pin will depress and disengage the locking tab on the connector housing.
4. Pull the terminated wire out of the housing. Wiggling the wire while pulling it out will help.

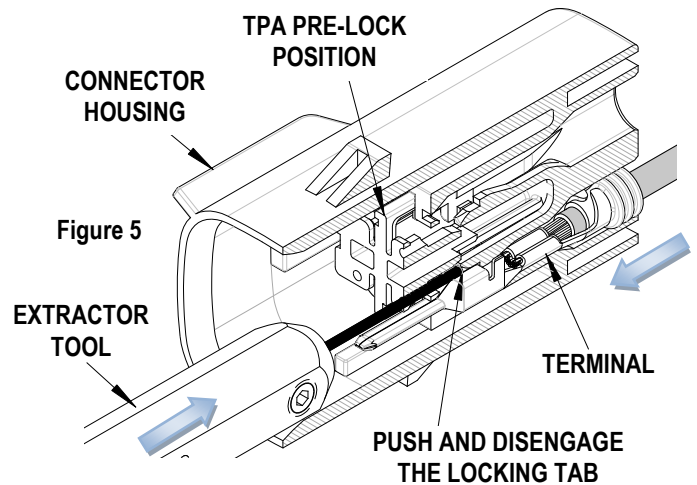

Figure 5

**CAUTION:** Molex specifications are valid only when used with Molex terminals, applicators and tooling.

Molex does not offer repair parts for Extractor Tools due to the inexpensive nature of these tools.

**Contact Information**

For more information on Molex application tooling please contact Molex at 1-800-786-6539.

Visit our Web site at <http://www.molex.com>