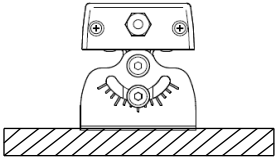
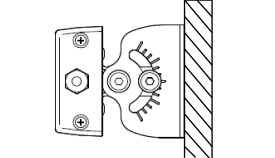
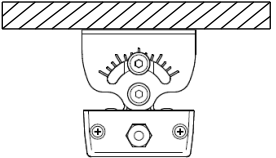

Drawing No.	Rev.	Page
SZW-306-W18	A	1/2

SPECIFICATIONS

[1. General Specifications]

Model	SZW-306		
Compatible models	CLK□-02□N-C□		
Mounting Location	Indoor		
Mounting Direction	Upright	Sideways	Inverted
			
Mass (Tolerance ±10%)	0.19kg (0.095kg×2, Included accessories)		
Quantity	2		
Vibration Resistance	20 m/s ² (IEC 60068-2-6:2009)		
Environmental Condition	Upright		
Shock Resistance	100m/s ² 16ms 1,000 times, 150m/s ² 11ms 3 times(IEC 60068-2-27)		
Environmental Condition	Upright		
Remarks	No restricted substances exceeding the thresholds of the RoHS Directive are contained.		

[2. Outer Dimension]

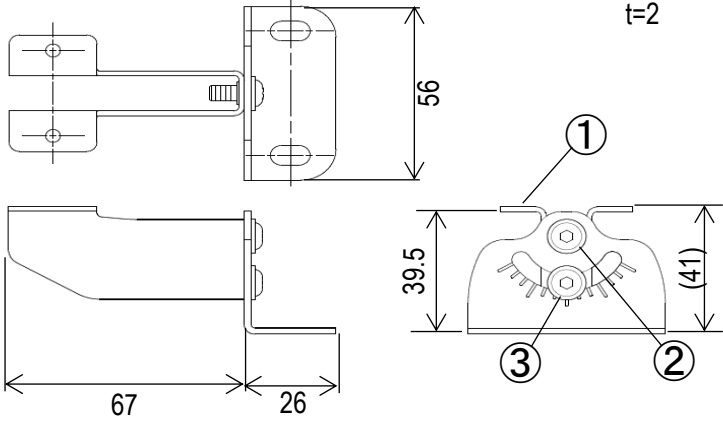

(Unit:mm)

No.	Name	Material	Quantity
1	Angle Adjustment Bracket	SUS	2
2	Center Screw	SUS	
3	Angle-locking Screw	SUS	

[3. Mounting Dimension Drawing]

(Unit:mm)

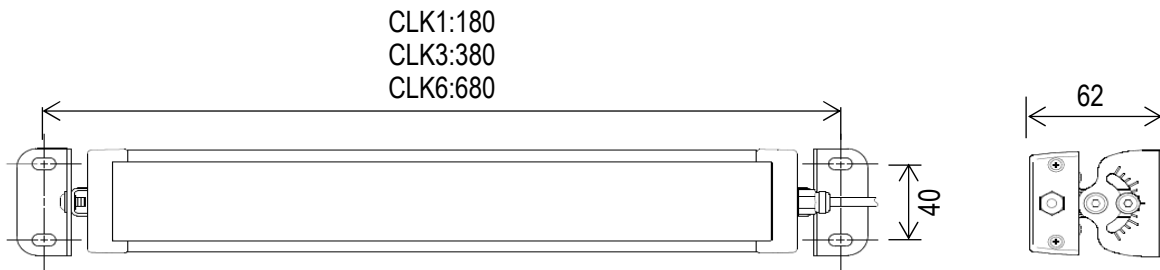

	Screw / Nut	Recommended Torque
Product Mounting	M6	4.8 N·m
Bracket Mounting	M4	1.7 N·m
Fixed Angle	M5	2.8 N·m

Accessories	Quantity
Bracket Mounting Screw	4

Movable Range

