

SATADOM-SV

3SE Series

Customer: _____

Customer

Part

Number: _____

Innodisk

Part

Number: _____

Innodisk

Model Name: _____

Date: _____

Innodisk Approver	Customer Approver

**Total Solution For
Industrial Flash Storage**

Table of contents

- LIST OF FIGURES6**
- 1. PRODUCT OVERVIEW7**
 - 1.1 INTRODUCTION OF INNODISK SATADOM-SV 3SE.....7**
 - 1.2 PRODUCT VIEW AND MODELS7**
 - 1.3 SATA INTERFACE.....7**
- 2. PRODUCT SPECIFICATIONS8**
 - 2.1 CAPACITY AND DEVICE PARAMETERS.....8**
 - 2.2 PERFORMANCE8**
 - 2.3 ELECTRICAL SPECIFICATIONS8**
 - 2.3.1 Power Requirement8**
 - 2.3.2 Power Consumption8**
 - 2.4 ENVIRONMENTAL SPECIFICATIONS9**
 - 2.4.1 Temperature Ranges9**
 - 2.4.2 Humidity.....9**
 - 2.4.3 Shock and Vibration9**
 - 2.4.4 Mean Time between Failures (MTBF)9**
 - 2.5 CE AND FCC COMPATIBILITY9**
 - 2.6 RoHS COMPLIANCE9**
 - 2.7 RELIABILITY10**
 - 2.8 TRANSFER MODE10**
 - 2.9 PIN ASSIGNMENT10**
 - 2.10 MECHANICAL DIMENSIONS.....11**
 - 2.11 ASSEMBLY WEIGHT11**
 - 2.12 SEEK TIME11**
 - 2.13 HOT PLUG.....11**
 - 2.14 NAND FLASH MEMORY.....11**
- 3. THEORY OF OPERATION12**
 - 3.1 OVERVIEW.....12**
 - 3.2 SATA III CONTROLLER12**
 - 3.3 ERROR DETECTION AND CORRECTION.....13**
 - 3.4 WEAR-LEVELING13**
 - 3.5 BAD BLOCKS MANAGEMENT13**
 - 3.6 POWER CYCLING13**
 - 3.7 GARBAGE COLLECTION.....13**
- 4. INSTALLATION REQUIREMENTS14**
 - 4.1 SATADOM-SV 3SE PIN DIRECTIONS14**

- 4.2 ELECTRICAL CONNECTIONS FOR SATADOM-SV 3SE..... 14**
- 4.3 DEVICE DRIVE 14**
- 4.4 PIN7 VCC..... 14**
- 5. PART NUMBER RULE16**

REVISION HISTORY

Revision	Description	Date
Preliminary	First Released	May, 2013
1.0	Official release	AUG, 2013
1.1	Wording correction	Jan, 2014

List of Tables

TABLE 1: DEVICE PARAMETERS	8
TABLE 2: PERFORMANCE	8
TABLE 3: INNODISK SATADOM-SV 3SE POWER REQUIREMENT	8
TABLE 4: POWER CONSUMPTION	8
TABLE 5: TEMPERATURE RANGE FOR SATADOM-SV 3SE	9
TABLE 6: SHOCK/VIBRATION TESTING FOR SATADOM-SV 3SE	9
TABLE 7: SATADOM-SV 3SE MTBF	9
TABLE 8: INNODISK SATADOM-SV 3SE PIN ASSIGNMENT	10

List of Figures

FIGURE 1: INNODISK SATADOM-SV 3SE	7
FIGURE 2: INNODISK SATADOM-SV 3SE BLOCK DIAGRAM	12
FIGURE 3: SIGNAL SEGMENT AND POWER SEGMENT	14

1. Product Overview

1.1 Introduction of Innodisk SATADOM-SV 3SE

Innodisk Serial ATA Disk on Module (SATADOM) supports SATA III standard (6.0Gb/s) interface with excellent performance, and SATADOM-SV 3SE is designed as the smallest form factor size that could enhance compatibility with various design applications. Particularly the 7th pin of standard SATA 7pin connector can optionally be the built-in power VCC pin. In other words, it could be connected directly to the SATA on-board socket on customers' system without additional power cable. Besides, the booting time for operation and the power consumption is less than hard disk drive (HDD). SATADOM-SV 3SE can work under harsh environment compile with ATA protocol, no additional drives are required, and the SSD can be configured as a boot device or data storage device.

1.2 Product View and Models

Innodisk SATADOM-SV 3SE is available in follow capacities within SLC flash ICs.

[SATADOM-SV 3SE 1GB](#)

[SATADOM-SV 3SE 2GB](#)

[SATADOM-SV 3SE 4GB](#)

[SATADOM-SV 3SE 8GB](#)

[SATADOM-SV 3SE 16GB](#)

[SATADOM-SV 3SE 32GB](#)



Figure 1: Innodisk SATADOM-SV 3SE

1.3 SATA Interface

Innodisk SATADOM-SV 3SE supports SATA III interface, and compliant with SATA I and SATA II. SATA III interface can work with Serial Attached SCSI (SAS) host system, which is used in server computer. Innodisk SATADOM-SV 3SE is compliant with Serial ATA Gen 1, Gen 2 and Gen 3 specification (Gen 3 supports 1.5Gbps /3.0Gbps/6.0Gbps data rate). SATA connector uses a standard 7-pin signal segment.

2. Product Specifications

2.1 Capacity and Device Parameters

SATADOM-SV 3SE device parameters are shown in Table 1.

Table 1: Device parameters

Capacity	Cylinders	Heads	Sectors	LBA	user space
1GB	1959	16	63	1974672	964
2GB	3897	16	63	3928176	1,918
4GB	7773	16	63	7835184	3,826
8GB	15525	16	63	15649200	7,641
16GB	16383	16	63	31277232	15,272
32GB	16383	16	63	62533296	30,534

2.2 Performance

Burst Transfer Rate: 6.0Gbps

Table 2: Performance

Capacity	1GB	2GB	4GB	8GB	16GB	32GB
Sequential Read (max.)	23 MB/sec	24MB/sec	220 MB/sec	250 MB/sec	290 MB/sec	300 MB/sec
Sequential Write (max.)	9 MB/sec	18 MB/sec	50 MB/sec	60 MB/sec	120 MB/sec	130 MB/sec

Note: the information is based on CrystalDiskMark 3.01 with file size 1000MB test patent

2.3 Electrical Specifications

2.3.1 Power Requirement

Table 3: Innodisk SATADOM-SV 3SE Power Requirement

Item	Symbol	Rating	Unit
Input voltage	V _{IN}	+5 DC +- 5%	V

2.3.2 Power Consumption

Table 4: Power Consumption

Mode	Power Consumption (mA)
Read	120 (max.)
Write	130 (max.)
Idle	100 (max.)

* Target: 32GB SATADOM-SV 3SE

2.4 Environmental Specifications

2.4.1 Temperature Ranges

Table 5: Temperature range for SATADOM-SV 3SE

Temperature	Range
Operating	Standard Grade: 0°C to +70°C
	Industrial Grade:-40°C to +85°C
Storage	-55°C to +95°C

2.4.2 Humidity

Relative Humidity: 10-95%, non-condensing

2.4.3 Shock and Vibration

Table 6: Shock/Vibration Testing for SATADOM-SV 3SE

Reliability	Test Conditions	Reference Standards
Vibration	7 Hz to 2K Hz, 20G, 3 axes	IEC 68-2-6
Mechanical Shock	Duration: 0.5ms, 1500 G, 3 axes	IEC 68-2-27

2.4.4 Mean Time between Failures (MTBF)

Table 7 summarizes the MTBF prediction results for various SATADOM-SV 3SE configurations. The analysis was performed using a RAM Commander™ failure rate prediction.

- **Failure Rate:** The total number of failures within an item population, divided by the total number of life units expended by that population, during a particular measurement interval under stated condition.
- **Mean Time between Failures (MTBF):** A basic measure of reliability for repairable items: The mean number of life units during which all parts of the item perform within their specified limits, during a particular measurement interval under stated conditions.

Table 7: SATADOM-SV 3SE MTBF

Product	Condition	MTBF (Hours)
Innodisk SATADOM-SV 3SE	Telcordia SR-332 GB, 25°C	>3,000,000

2.5 CE and FCC Compatibility

SATADOM-SV 3SE conforms to CE and FCC requirements.

2.6 RoHS Compliance

SATADOM-SV 3SE is fully compliant with RoHS directive.

2.7 Reliability

Parameter	Value
Read Cycles	Unlimited Read Cycles
Flash endurance	100,000 P/E cycles
Wear-Leveling Algorithm	Support
Bad Blocks Management	Support
Error Correct Code	Support
TBW	
1GB	90 (Sequential write)
2GB	180 (Sequential write)
4GB	360 (Sequential write)
8GB	720 (Sequential write)
16GB	1440 (Sequential write)
32GB	2880 (Sequential write)

2.8 Transfer Mode

SATADOM-SV 3SE support following transfer mode:

- Serial ATA I 1.5Gbps
- Serial ATA II 3.0Gbps
- Serial ATA III 6.0Gbps

2.9 Pin Assignment

Innodisk SATADOM-SV 3SE uses a standard SATA pin-out. See Table 8 for SATADOM-SV 3SE pin assignment.

Table 8: Innodisk SATADOM-SV 3SE Pin Assignment

Name	Type	Description
Pin 1	GND	Shielding
Pin 2	A+	Differential signal to A
Pin 3	A-	Differential signal to A-
Pin 4	GND	Shielding
Pin 5	B-	Differential signal to B-
Pin 6	B+	Differential signal to B
Pin 7	GND/VCC	Shielding/Power

2.10 Mechanical Dimensions

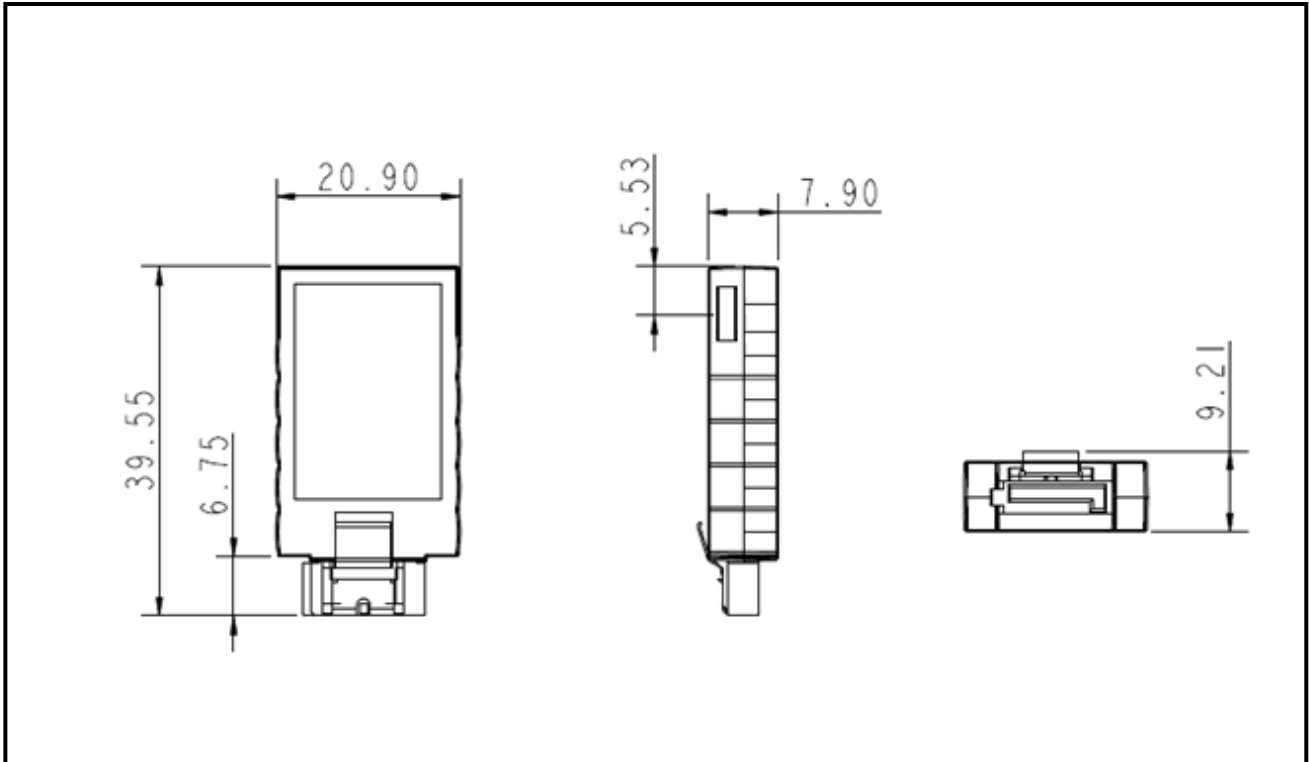

2.11 Assembly Weight

An Innodisk SATADOM-SV 3SE within flash ICs, 32GB's weight is 7 grams approximately.

2.12 Seek Time

Innodisk SATADOM-SV 3SE is not a magnetic rotating design. There is no seek or rotational latency required.

2.13 Hot Plug

The SSD support hot plug function and can be removed or plugged-in during operation. User has to avoid hot plugging the SSD which is configured as boot device and installed operation system.

Surprise hot plug : The insertion of a SATA device into a backplane (combine signal and power) that has power present. The device powers up and initiates an OOB sequence.

Surprise hot removal: The removal of a SATA device from a powered backplane, without first being placed in a quiescent state.

2.14 NAND Flash Memory

Innodisk SATADOM-SV 3SE uses Single Level Cell (SLC) NAND flash memory, which is non-volatility, high reliability and high speed memory storage. There are only two statuses 0 or 1 of one cell. Read or Write data to flash memory for SSD is control by microprocessor.

3. Theory of Operation

3.1 Overview

Figure 2 shows the operation of Innodisk SATADOM-SV 3SE from the system level, including the major hardware blocks.

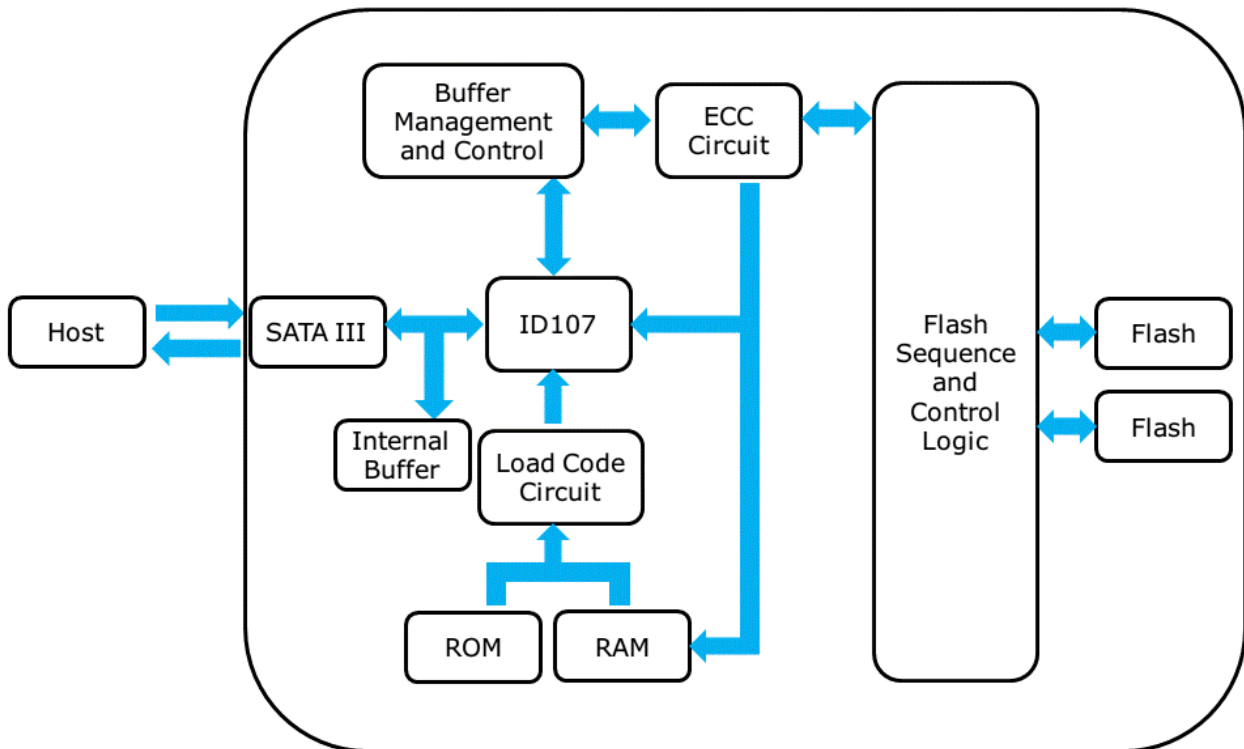

Figure 2: Innodisk SATADOM-SV 3SE Block Diagram

Innodisk SATADOM-SV 3SE integrates a SATA III controller and NAND flash memories. Communication with the host occurs through the host interface, using the standard ATA protocol. Communication with the flash device(s) occurs through the flash interface.

3.2 SATA III Controller

Innodisk SATADOM-SV 3SE is designed with ID 107, a SATA III 6.0Gbps (Gen. 3) controller. The Serial ATA physical, link and transport layers are compliant with Serial ATA Gen 1, Gen 2 and Gen 3 specification (Gen 3 supports 1.5Gbps/3.0Gbps/6.0Gbps data rate). The controller has 2 channels for flash interface.

3.3 Error Detection and Correction

Highly sophisticated Error Correction Code algorithms are implemented. The ECC unit consists of the Parity Unit (parity-byte generation) and the Syndrome Unit (syndrome-byte computation). This unit implements an algorithm that can correct 40 bits per 1024 bytes in an ECC block. Code-byte generation during write operations, as well as error detection during read operation, is implemented on the fly without any speed penalties.

3.4 Wear-Leveling

Flash memory can be erased within a limited number of times. This number is called the **erase cycle limit** or **write endurance limit** and is defined by the flash array vendor. The erase cycle limit applies to each individual erase block in the flash device.

Innodisk SATADOM-SV 3SE uses a static wear-leveling algorithm to ensure that consecutive writes of a specific sector are not written physically to the same page/block in the flash. This spreads flash media usage evenly across all pages, thereby extending flash lifetime.

3.5 Bad Blocks Management

Bad Blocks are blocks that contain one or more invalid bits whose reliability are not guaranteed. The Bad Blocks may be presented while the SSD is shipped, or may develop during the life time of the SSD. When the Bad Blocks is detected, it will be flagged, and not be used anymore. The SSD implement Bad Blocks management, Bad Blocks replacement, Error Correct Code to avoid data error occurred. The functions will be enabled automatically to transfer data from Bad Blocks to spare blocks, and correct error bit.

3.6 Power Cycling

Innodisk's power cycling management is a comprehensive data protection mechanism that functions before and after a sudden power outage to SSD. Low-power detection terminates data writing before an abnormal power-off, while table-remapping after power-on deletes corrupt data and maintains data integrity. Innodisk's power cycling provides effective power cycling management, preventing data stored in flash from degrading with use.

3.7 Garbage Collection

Garbage collection is used to maintain data consistency and perform continual data cleansing on SSDs. It runs as a background process, freeing up valuable controller resources while sorting good data into available blocks, and deleting bad blocks. It also significantly reduces write operations to the drive, thereby increasing the SSD's speed and lifespan.

4. Installation Requirements

4.1 SATADOM-SV 3SE Pin Directions

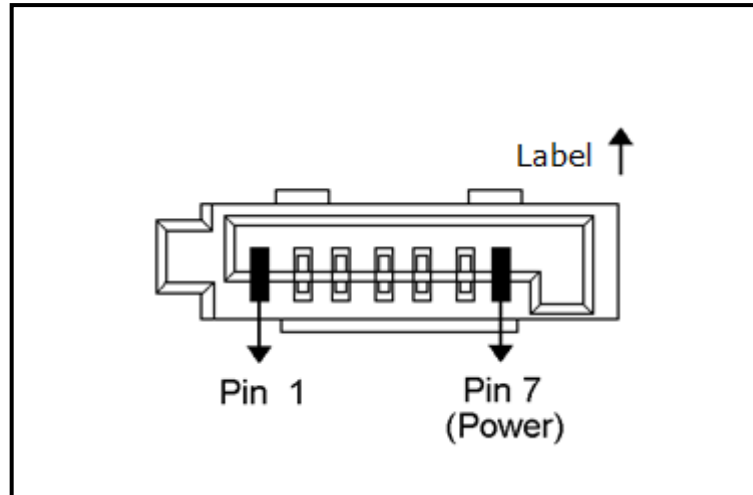

Figure 3: Signal Segment and Power Segment

4.2 Electrical Connections for SATADOM-SV 3SE

A Serial ATA device may be either directly connected to a host or connected to a host through a cable. For connection via cable, the cable should be no longer than 1meter. The SATA interface has a separate connector for the power supply. Please refer to the pin description for further details.

4.3 Device Drive

No additional device drives are required. The Innodisk SATADOM-SV 3SE can be configured as a boot device.

4.4 Pin7 VCC

Innodisk SATADOM series products have an optional design to provide power supply through the 7th Pin of SATA connector, and customers DO NOT have to use the power cable for power supply. Such a cable-less design of SATADOM series products with Pin7 VCC brings more convenience to customers' system. The followings are the points customers have to be careful of while designing in SATADOM series products with Pin7 VCC.

SATADOM series products with Pin7 VCC is designed with a fuse (poly switch 500mA, 6V) on Pin7's circuit. Such a design could avoid any potential damage to customers' system.

To have the advantages of SATADOM series with Pin7 VCC, and to avoid any potential damage to customers' board designed with VCC power supply, Innodisk suggests that customers MUST

design their board with a fuse which should be designed before the SATA socket Pin7 VCC. In other words, customers are suggested NOT TO layout 5V VCC to SATA socket on board directly. A circuit diagram example to explain this is shown as below.

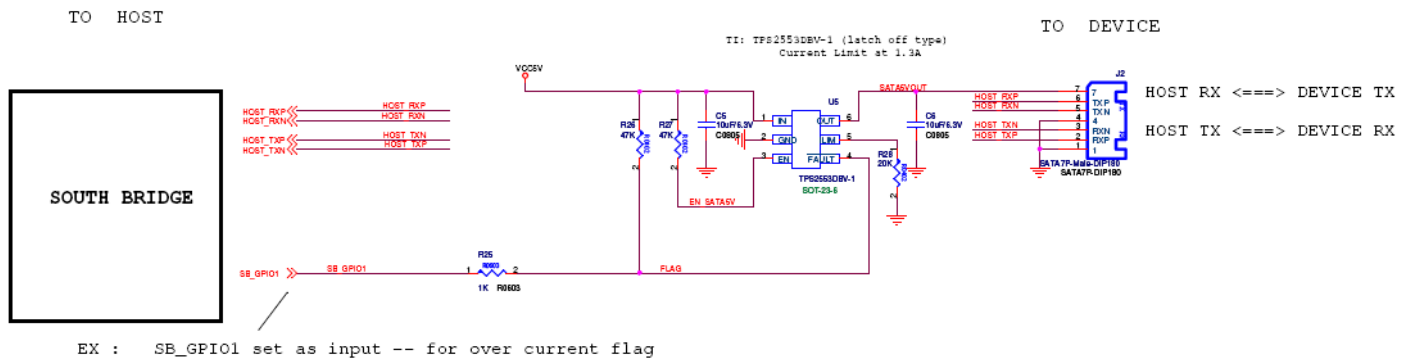

5. Part Number Rule

CODE	1	2	3	4	5	6	7	8	9	10	11	12	13	14	15	16	17	18	19	20	21	
	D	E	S	S	V	-	3	2	G	D	0	7	S	C	A	D	B	-	X	X	X	
Definition																						
Code 1 st (Disk)											Code 14 th (Operation Temperature)											
D : Disk											C: Standard Grade (0°C ~ +70°C)											
Code 2 nd (Feature set)											W: Industrial Grade (-40°C ~ +85°C)											
E : Embedded series											Code 15 th (Internal control)											
Code 3 rd ~5 th (Form factor)											A~Z: BGA PCB version.						1~9: TSOP PCB version.					
SSV: SATADOM-SV											Code 16 th (Channel of data transfer)											
Code 7 th ~9 th (Capacity)											S: Single Channel											
01G:1GB			02G:2GB			04G:4GB			08G:8GB			D: Dual Channels										
16G:16GB			32G: 32GB																			
Code 10 th ~12 th (Controller)											Code 17 th (Flash Type)											
D07: ID107											B: Toshiba SLC											
Code 13 th (Flash mode)											Code 18 th (pin7 type)											
S: Synchronous NAND.											F: Pin7 version (Optional)											
A: Asynchronous NAND.											Code 19 th ~21 st (Customize code)											

Appendix

Verification of Compliance

Product Name : SATADOM-SV 3ME /3SE / 3IE
Model Number : D@SSV-XXXD07* # % ※ & (F)
 @: Feature set (G: EverGreen, H: iSLC, R:InnoRobust ,
 E: Embedded)
 XXX: 1GB-32GB
 * : Flash Mode
 # : Temperature (C : Commercial Temp W : Industrial Temp)
 % : PCB Version (A, B, C... or 1, 2, 3...)
 ※ : Channel (S : Single, D : Dual, Q : Quad, E : Eight)
 & : Flash Vender (T : Micron SLC, S : Samsung SLC, N : Micron
 MLC, B : Toshiba SLC, C : Toshiba MLC, F: Sandisk SLC, X: SLC)
Applicant : Innodisk Corporation
Address : 9F, No.100, Sec. 1, Xintai 5th Rd., Xizhi Dist., New Taipei City 221,
 Taiwan
Report Number : O22-U070-1306-271
Issue Date : August 6, 2013
Applicable Standards : EN 55022:2010 Class B ITE
 AS/NZS CISPR22:2009 Class B ITE
 EN 55024:2010
 EN 61000-4-2:2009
 EN 61000-4-3:2006+A1:2008+A2:2010
 EN 61000-4-4:2004+A1:2010

Based on the EMC Directive 2004/108/EC and the specifications of the customer, one sample of the designated product has been tested in our laboratory and found to be in compliance with the EMC standards cited above.



TAF 0905
 FCC CAB Code TW1053
 NVLAP Lab Code 200575-0
 IC Code 4699A
 VCCI Accep. No. R-1527, C-1609, T-1441, G-10,
 C-4400, T-1334, G-614



Central Research Technology Co.
 EMC Test Laboratory
 11, Lane 41, Fushuen St., Jungshan Chiu,
 Taipei, Taiwan, 104, R.O.C.
 Tel : 886-2-25984568
 Fax: 886-2-25984546

(Tsun-Yu Shih/ General Manager)

Date: August 6, 2013

Verification of Compliance

Product Name : SATADOM-SV 3ME /3SE / 3IE
 Model Number : D@SSV-XXXD07*#%*&(F)
 @: Feature set (G: EverGreen, H: iSLC, R:InnoRobust ,
 E: Embedded)
 XXX: 1GB-32GB
 * : Flash Mode
 # : Temperature (C : Commercial Temp W : Industrial Temp)
 % : PCB Version (A, B, C.... or 1, 2, 3...)
 ※ : Channel (S : Single, D : Dual, Q : Quad, E : Eight)
 & : Flash Vender (T : Micron SLC, S : Samsung SLC, N : Micron
 MLC,B : Toshiba SLC, C: Toshiba MLC, F: Sandisk SLC, X: SLC)

Applicant : Innodisk Corporation
 Address : 9F, No.100, Sec. 1, Xintai 5th Rd., Xizhi Dist., New Taipei City 221,
 Taiwan

Report Number : F-U070-1306-271
 Issue Date : August 6, 2013

Applicable Standards : FCC Part 15, Subpart B Class B ITE
 ANSI C63.4:2009
 Industry Canada ICES-003 Issue 5
 CSA-IEC CISPR22-10 Class B ITE

One sample of the designated product has been tested in our laboratory and found to be in compliance with the FCC rules cited above.

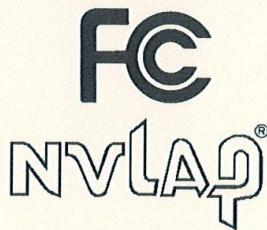

NVLAP LAB CODE 200575-0

TAF 0905

FCC CAB Code TW1053

IC Code 4699A

VCCI Accep. No. R-1527, C-1609, T-1441, G-10,
 C-4400, T-1334, G-614



Central Research Technology Co.
 EMC Test Laboratory
 11, Lane 41, Fushuen St., Jungshan Chiu,
 Taipei, Taiwan, 104, R.O.C.
 Tel : 886-2-25984568
 Fax: 886-2-25984546

A handwritten signature in black ink, appearing to read 'Tsun-Yu Shih'.

(Tsun-Yu Shih/ General Manager)

Date: August 6, 2013