

Power management IC for MPU with 2 buck converters and 4 LDOs

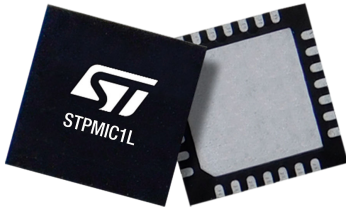

Features

- Input voltage range from 2.8 V to 5.5 V
- 2 buck SMPS converters with adaptive constant on-time (COT) topology
- 2 adjustable general-purpose LDOs
- 1 LDO for DDR3L/DDR4 termination (sink-source) or as a general-purpose LDO
- 1 LDO for USB PHY supply
- 2 MHz switching frequency buck converters with forced PWM
- User programmable non-volatile memory (NVM), enabling scalability to support a wide range of applications
- Immediate output alternate settings toggle via dedicated power control pins
- Programmable output voltages turn ON/OFF sequences
- I²C and digital I/O control interfaces
- 2 GPO output controls for external commands
- VFQFPN 28L (4.0 x 4.0 x 1.0 mm)

Maturity status link

STPMIC1L

Device summary

Order code	STPMIC1LAPQR
	STPMIC1LBPQR
	STPMIC1LDPQR
Packing	VFQFPN 28L (4.0 x 4.0 x 1.0 mm)

Applications

- Power management for embedded microprocessor units
- Wearable and IoT devices
- Portable devices
- Human machine interfaces
- Smart home devices
- Power management unit companion chip for the STM32MP13/15 MPUs

Description

The **STPMIC1L** is a fully integrated power management IC designed for STM32MP1x microprocessor unit (MPU) series applications that require low power and high efficiency.

The device integrates advanced low-power features controlled by a host processor through I²C and I/O interfaces.

STPMIC1L regulators are designed to supply power to the application processor and to external system peripherals such as DDR and flash memory. The **STPMIC1L** directly supplies the core chipset: MPU, DDR, and one flash memory. It can also control discrete regulators through its GPO pins to supply other system devices.

Two buck switched-mode power supplies (SMPS) are optimized to provide excellent transient response and output voltage precision for a wide range of operating conditions. An advanced pulse-width modulation (PWM) phase-shift synchronization technique with an integrated phase-locked loop (PLL) reduces noise and electromagnetic interference (EMI).

1 Device configuration table

The STPMIC1L has a non-volatile memory (NVM) that enables scalability to support a wide range of applications:

- Default output voltage, POWER_UP/POWER_DOWN sequences, protection behavior, auto turn-on functionality, and an I²C slave address.
- The STPMIC1LA, STPMIC1LB and STPMIC1LD are preprogrammed devices to support the STM32MP1x series application processor versions.
- Straightforward NVM reprogramming via I²C to facilitate mass production directly in target applications.
- Possibility to lock NVM content to prevent further reprogramming by writing LOCK_NVM bit.

Table 1. Default configuration table

	Default configuration table								
	STPMIC1LA			STPMIC1LB			STPMIC1LD		
	Default output voltage	Default output current	Rank	Default output voltage	Default output current	Rank	Default output voltage	Default output current	Rank
LDO2	3.3 V	0.4 A OCP level 1	1	1.8 V	0.4 A OCP level 1	1	3.3 V	0.4 A OCP level 1	1
LDO3	-	OCP level 1	0	-	OCP level 1	0	-	OCP level 0	0
LDO4	3.3 V	40 mA OCP level 0	5	3.3 V	40 mA OCP level 0	5	3.3	40 mA OCP level 0	5
LDO5	3.3 V	0.4 A OCP level 0	4	2.9 V	0.4 A OCP level 0	4	3.3 V	0.4 A OCP level 0	4
BUCK1	1.22 V	1.5 A OCP level 1	2	1.22 V	1.5 A OCP level 1	2	1.25 V	1 A OCP level 1	2
BUCK2	-	1.0 A OCP level 1	0	-	1.0 A OCP level 1	0	1.25 V	1 A OCP level 1	3
GPO1	-	-	3	-	-	3	-	-	5
GPO2	-	-	0	-	-	0	-	-	0
VINOK_Rise	4.0 V		-	3.3 V		-	4.0 V		-
VINOK_Fall	3.5 V		-	2.8 V		-	3.5 V		-

All output voltages with Rank = 0 are by default programmed with 0 Dec (refer to [Table 15](#) and [Table 16](#)).

The startup sequence is split into six steps (Rank = 0 to Rank = 5).

Each buck converter or LDO regulator can be programmed to be automatically turned ON in one of these phases. Each rank phase is separated by a delay (1.5 ms, 3 ms, 4.5 ms, or 6 ms) programmed in the NVM:

- Rank = 0: rail not turned ON automatically, no output voltage appears after POWER-UP
- Rank = 1: rail automatically turned ON after 7 ms following a turn_ON condition
- Rank = 2: rail automatically turned ON after a further 1.5 ms (by default)
- Rank = 3: rail automatically turned ON after a further 1.5 ms (by default)
- Rank = 4: rail automatically turned ON after a further 1.5 ms (by default)
- Rank = 5: rail automatically turned ON after a further 1.5 ms (by default)

Whatever the STPMIC1L version, the AUTO_TURN_ON option is set.

2 Typical application schematic

Figure 1. Typical application schematic

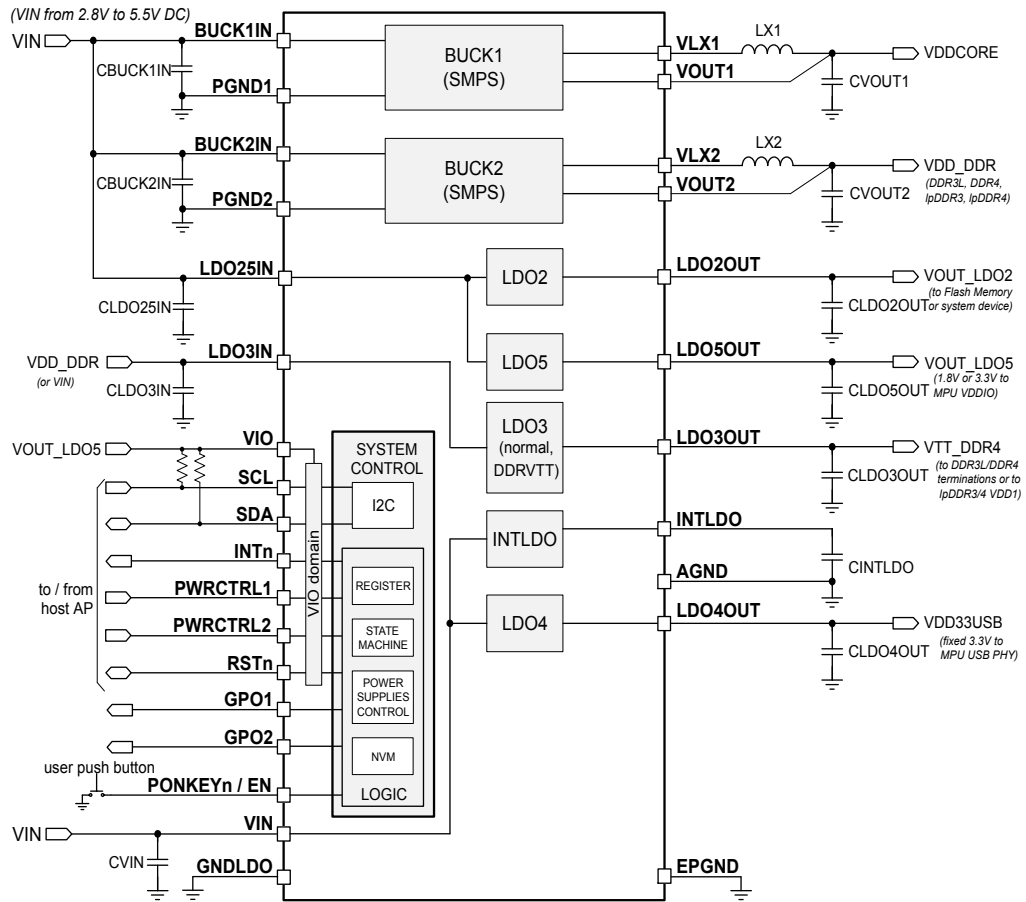

Note: All BUCKxIN pins must be connected to the same voltage node as VIN.
VIN is the main STPMIC1L supply. All buck converters and linear regulators have dedicated or shared power supply pins. The dedicated VIO supply is for all digital interface pins, except GPOs.
No other supply voltages must be applied before VIN or set higher than VIN.

2.1 Recommended external components

Table 2. Passive components

Component	Manufacturer	Part number	Value	Size
CVIN, CLDO2OUT, CLDO4OUT, CLDO5OUT, CINTLDO	Murata	GRM155R60J475ME47D	4.7 μ F, 6.3 V	0402
CLDO25IN		GRM155R61E105KA12D	1 μ F, 25 V	0402
CBUCK1IN, BUCK2IN		GRM188R61A106ME69D	10 μ F, 10 V	0603
CVOUT1 (0.5 V - 1.5 V) LV		GRM188R60J226MEA0D	2 x 22 μ F, 6.3 V	0603
CVOUT1 (1.5 V - 4.2 V) HV		GRM21BR61A226ME51L	2 x 22 μ F, 10 V	0805
CVOUT2		GRM188R60J226MEA0D	2 x 22 μ F, 6.3 V	0603
CLDO3IN, CLDO3OUT		GRM155R60J106ME05D	10 μ F, 6.3 V	0402
LX1		SAMSUNG	CIGT201610LH1R0MNE	1 μ H
LX2	CIGT201610LH1R0MNE		1 μ H	0806

Note: All the components above refer to a typical application working in an environment up to +85 °C ambient temperature. The operation of the device is not limited to the choice of these external components.

2.2 Pin out and pin description

Figure 2. Pin configuration VFQFPN 28L top view

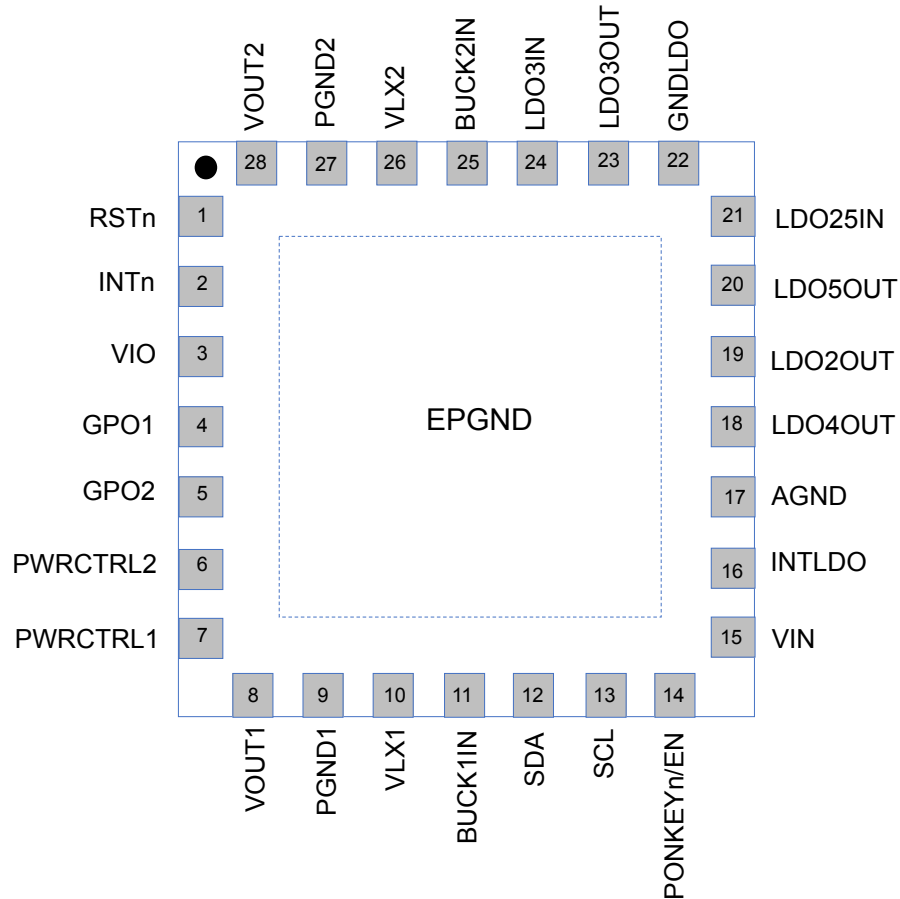

Table 3. Pin description

Pin name	A/D ⁽¹⁾	I/O ⁽¹⁾	Location	Description (default configuration)	Not used pin connection
RSTn	D	I/O	1	Bidirectional reset (active low with internal pull-up)	Floating
INTn	D	O	2	Interrupt (active low with internal pull-up)	Floating
VIO	A	I	3	I/O voltage (for all digital signals except PONKEYn/En and GPO1/2)	VIO
GPO1	D	O	4	External Control 1	Floating
GPO2	D	O	5	External Control 2	Floating
PWRCTRL2	D	I	6	Power control 2 mode (pull-up and pull-down, pull-up active by default)	VIO or floating
PWRCTRL1	D	I	7	Power control 1 mode (pull-up and pull-down, pull-up active by default)	VIO or floating
VOUT1	A	I	8	Input feedback signal buck converter 1	Floating
PGND1	A	-	9	Power ground buck converter 1	GND
VLX1	A	O	10	LX node buck converter 1	Floating
BUCK1IN	A	I	11	Power input buck converter 1	VIN
SDA	D	I	12	I ² C serial data	VIO

Pin name	A/D ⁽¹⁾	I/O ⁽¹⁾	Location	Description (default configuration)	Not used pin connection
SCL	D	I/O	13	I ² C serial clock	VIO
PONKEYn/En	D	I	14	User power ON key / Enable (active low with internal pullup by default)	Floating
VIN	A	I	15	Main power input - power input LDO4, VREF	VIN
INTLDO	A	O	16	Internal LDO	4.7 µF capacitor
AGND	A	-	17	Main analog ground	GND
LDO4OUT	A	O	18	Output voltage LDO4	Floating
LDO2OUT	A	O	19	Output voltage LDO2	Floating
LDO5OUT	A	O	20	Output voltage LDO5	Floating
LDO25IN	A	I	21	Power input LDO2 and LDO5	VIN
GNDLDO	A	-	22	LDO GND	GND
LDO3OUT	A	O	23	Output voltage LDO3	Floating
LDO3IN	A	I	24	Power input LDO3	VIN
BUCK2IN	A	I	25	Power input buck converter 2	VIN
VLX2	A	O	26	LX node buck converter 2	Floating
PGND2	A	-	27	Power ground buck converter 2	GND
VOU2	A	I	28	Input feedback signal buck converter 2	Floating
EPGND	A	-	ePad	Exposed pad to be connected to ground	GND

1. A: analog; D: digital; I/O: input/Output

3 Electrical and timing characteristics

3.1 Absolute maximum ratings

Table 4. Absolute maximum ratings

Parameter	Min.	Unit
VIN, BUCKxIN, VLXx, LDO3IN, LDOxIN, PONKEYn/En	-0.5 to +6.5	V
VIO, SDA, SCL, RSTn, PWRCTRLx, INTn	-0.5 to +4.2	
INTLDO	-0.5 to +2	
VOUT1, LDOxOUT, GPO1, GPO2	-0.5 to +5.5	
VOUT2	-0.5 to +3	
ESD HBM	±1000	V
ESD CDM	±500	

Note: **Stressing the device above the absolute maximum ratings may cause permanent damage to the device. These are stress ratings only and operation of the device at these or any other conditions above those indicated in the operating section of this specification is not implied. Exposure to absolute maximum rating conditions may affect device reliability.**

3.2 Thermal characteristics

Table 5. Thermal characteristics

Symbol	Parameter	Value	Unit
T_j	Absolute maximum junction temperature	-40 to +150	°C
T_{JAMR}	Absolute maximum junction temperature	-40 to +160	
TA	Operating ambient temperature	-40 to +105	
Θ_{JC}	Junction-case package thermal resistance on 2s2p std JEDEC board (JESD51-7)	6	°C/W
Θ_{JA}	Junction-ambient package thermal resistance on 2s2p std JEDEC board (JESD51-7)	32	

3.3 Consumption in typical application scenarios

STPMIC1L V_{IN} input current consumption with all supply pins connected to V_{IN} except $V_{LDO3IN} = V_{OUT2} = 1.25\text{ V}$, $V_{IN} = 5\text{ V}$, $V_{IO} = 3.3\text{ V}$ from LDO2OUT at $T_j = +25\text{ }^\circ\text{C}$, unless otherwise specified.

Table 6. Consumption in typical application scenarios

Application mode	Application description	Conditions	Typ.	Unit
OFF	AP and peripherals are powered OFF, waiting for a turn-on event to start.	PMIC in OFF state. Turn-on from PONKEYn/EN and I ² C inactive. All regulators OFF. GPOx deasserted.	53 ⁽¹⁾	μA
STANDBY	AP is in STANDBY mode (suspend to flash). All peripherals are powered OFF.	PMIC in POWER_ON state. IRQ from any source and PWRCTRLx active. LDO2 ON, VLDO2OUT = 3.3 V (VDDIO). All other regulators OFF and GPOx deasserted. All outputs without load. No activity on I ² C.	110	
STOP	AP is in LPLV-STOP1 (Core/CPU on-low voltage) DDR3L is in self-refresh. All peripherals are powered OFF.	PMIC in POWER_ON state. IRQ from any source and PWRCTRLx active. BUCK1 ON, VOUT1 = 0.9 V (VDDCORE). BUCK2 ON, VOUT2 = 1.35 V (VDD_DDR). LDO2 ON, VLDO2OUT = 3.3 V (VDDIO). All other regulators OFF. All outputs without load. No activity on I ² C.	370	
RUN	Application is in RUN (Core, CPU, on-nominal) DDR3L is running.	PMIC in POWER_ON state. IRQ from any source and PWRCTRLx active. BUCK1 ON, VOUT1 = 1.25 V (VDDCORE). BUCK2 ON, VOUT2 = 1.35 V (VDD_DDR). LDO3 ON in sink/src (VTT_DDR). LDO2 ON, VLDO2OUT = 3.3 V (VDDIO). All other regulators OFF. All outputs without load. No activity on I ² C.	650	

1. Current consumption, 100 μA max at $T_j = -40\text{ }^\circ\text{C}$ to $+105\text{ }^\circ\text{C}$.

3.4 Electrical and timing parameter specifications

All parameters are specified at $V_{IN} = V_{BUCKxIN} = V_{LDOxIN} = 5\text{ V}$, except $V_{LDO3IN} = V_{OUT2}$, $V_{OUT1} = 1.25\text{ V}$, $V_{OUT2} = 1.35\text{ V}$, $V_{LDO5OUT} = 3.3\text{ V}$, $V_{LDO2OUT} = 3.3\text{ V}$, $V_{LDO3OUT} = \text{snk/src}$, $V_{LDO4OUT} = 3.3\text{ V}$, $V_{IO} = V_{LDO2OUT}$, $T_J = -40\text{ }^\circ\text{C}$ to $+125\text{ }^\circ\text{C}$, with recommended BOM, unless otherwise specified.

3.4.1 General section

Table 7. Electrical and timing parameter specifications (general section)

Symbol	Parameter	Test conditions	Min.	Typ.	Max.	Unit
General section						
V_{IN}	Input voltage range		2.8	3.6 or 5	5.5	V
V_{INPOR_Rise}	V_{INPOR} rising threshold		2.2	2.3	2.4	V
V_{INPOR_Fall}	V_{INPOR} falling threshold			2.1	2.2	V
V_{INOK_Rise}	V_{INOK} rising threshold	Programmable value defined in the NVM register	3	3.1	3.2	V
			3.2	3.3	3.4	
			3.35	3.5	3.6	
			3.8	4.0	4.1	
V_{INOK_HYST}	V_{INOK} hysteresis	Programmable value defined in the NVM register		200 300 400 500		mV
V_{INOK_Fall}	V_{INOK} falling threshold	Defined indirectly by V_{INOK_Rise} and V_{INOK_HYST} settings		V_{INOK_Rise} - V_{INOK_HYST}		mV
t_{VINOK_Fall}	V_{INOK} falling delay	When V_{IN} is crossing V_{INOK_Fall} , PMIC power-down then cannot restart before t_{VINOK_Fall} delay, even if $V_{IN} > V_{INOK_Rise}$		100		ms
V_{INLOW_Rise}	V_{INLOW} rising threshold	Programmable value defined in register V_{INLOW_CR}	+20 +300	$V_{INOK_Fall} + 50$ to $V_{INOK_Fall} + 400$	+80 +500	mV
V_{INLOW_HYST}	V_{INLOW} hysteresis	Programmable value defined in register V_{INLOW_CR}	90	100	110	mV
			180	200	220	
			270	300	330	
			360	400	440	
V_{INLOW_Fall}	V_{INLOW} falling threshold	Defined directly by V_{INLOW_Rise} and V_{INLOW_HYST} settings		V_{INLOW_Rise} + V_{INLOW_HYST}		mV
T_{WRN_Rise}	Warning temperature rising		115	125	135	$^\circ\text{C}$
T_{WRN_Fall}	Warning temperature falling		95	105	120	$^\circ\text{C}$
T_{SHDN_Rise}	Shutdown temperature rising		140	150	160	$^\circ\text{C}$
T_{SHDN_Fall}	Shutdown temperature falling		105	115	130	$^\circ\text{C}$
t_{TSHDN_DLY}	Shutdown temperature falling delay			3		s
t_{OCPDB_LDO}	LDO OCP turn-off delay			5		ms
t_{OCPDB_BUCK}	BUCK OCP turn-off delay			5		ms

Symbol	Parameter	Test conditions	Min.	Typ.	Max.	Unit
$t_{\text{HICCUP_DLY}}$	Hiccup mode OFF delay	Programmable value defined in NVM_BUCKS_IOUT_SHR2 NVM register		0 100 500 1000		ms
t_{WD}	Watchdog timer	Programmable value defined in the register		1 to 256		s
		Timer programming step		1		
NVM_{END}	NVM write cycles endurance	Recommended maximum writing cycles ⁽¹⁾			10	Cycle
$V_{\text{NVM_PROG}}$	NVM min voltage for write operation		3.8			V

1. NVM writing procedures must be performed under controlled electrical/environmental values.

3.4.2 Digital interface

Table 8. Electrical and timing parameter specifications (digital interface)

Symbol	Parameter	Test conditions	Min.	Typ.	Max.	Unit
Digital interface						
V_{IO}	V_{IO} input voltage for IO signal		1.7	1.8 or 3.3	3.6	V
V_{IL}	PONKEYn/EN input low voltage		0		$0.3 \times V_{INTLDO}^{(2)}$	V
	RSTn, PWRCTRLx input low voltage		0		$0.3 \times V_{IO}$	
	SDA, SCL input low voltage	I ² C NXP UM10204 revision 5 compliant (October 2012)	0		$0.3 \times V_{IO}$	
V_{IH}	PONKEYn/EN input high voltage		$0.7 \times V_{INTLDO}^{(2)}$		V_{IN}	V
	RSTn, PWRCTRLx input high voltage		$0.7 \times V_{IO}$		V_{IO}	
	SDA, SCL input high voltage	I ² C NXP UM10204 revision 5 compliant (October 2012)	$0.7 \times V_{IO}$		V_{IO}	
V_{HYST}	PONKEYn/EN input hysteresis			$0.1 \times V_{INTLDO}^{(2)}$		V
	RSTn, PWRCTRLx, input hysteresis			$0.1 \times V_{IO}$		
	SDA, SCL input hysteresis	I ² C NXP UM10204 revision 5 compliant (October 2012)		$0.1 \times V_{IO}$		
V_{OL}	RSTn, INTn, GPOx output low voltage	$I_{IO} = 4 \text{ mA}$	-		0.4	V
	SDA, SCL output low voltage	$I_{IO} = 4 \text{ mA}$, I ² C NXP UM10204 revision 5 compliant (October 2012)	-		0.4	
V_{OH}	GPOx output high voltage	$I_{IO} = 4 \text{ mA}$			$V_{IN} - 0.4$	V
R_{PD}	PWRCTRLx pins pull-down resistor	Internally connected to GND	60	90	140	K Ω
	PONKEYn/EN pin pull-down resistor	Internally connected to GND	60	100	140	
R_{PU}	RSTn, INTn, PWRCTRLx pins pull-up resistor	Internally connected to V_{IO}	50	80	120	K Ω
	PONKEYn/EN pin pull-up resistor	Internally connected to V_{IN}	80	120	140	
$t_{PONKEYnDB}$	PONKEYn/EN pin debounce filter duration	No debounce filter for EN		30		ms
t_{RSTnAS}	RSTn assertion time ⁽¹⁾		30			μs

1. Pulse smaller than t_{RSTnAS} duration. PMIC RSTn has no debounce filter. PMIC must detect a pulse equal to or longer than t_{RSTnAS} duration

2. $V_{INTLDO} = 1.8 \text{ V}$

3.4.3 LDO2 and LDO5
Table 9. Electrical and timing parameter specifications.

Symbol	Parameter	Test conditions	Min.	Typ.	Max.	Unit
LDO2, LDO5						
V_{LDOIN}	Main input voltage range		2.8		5.5	V
V_{LDOOUT}	Output voltage	$V_{LDOIN} > V_{LDOOUT} + V_{LDODROP}$ Programmable value.		0.9 to 4.0		
		Voltage programming step		100		mV
$V_{LDOOUT-ACC}$	Output voltage accuracy	$2.8\text{ V} < V_{LDOIN} < 5.0\text{ V}$ $V_{LDOIN} > V_{LDOOUT} + V_{LDODROP}$ $100\ \mu\text{A} < I_{LDOOUT} < 350\text{ mA}$	-2		2	%
I_{LDOLIM}	Output current limitation	$2.8\text{ V} < V_{LDOIN} < 5.5\text{ V}$ I_{LDOLIM} programmable in NVM_LDOS_IOUT_SHR (Ref. NVM setting A and B versions)	50		75	mA
			100		150	
			200		300	
			400		600	
$I_{LDO2/5Q}$	Total quiescent current	$I_{LDOOUT} = 0\text{ mA}$, $V_{LDOIN} = 5\text{ V}$ Measured from the related common input pin, LDO25IN		9	20	μA
$I_{LDO2/5IN_LKG}$	Input leakage current	LDO2/5 output disabled Measured from the related common input pin, LDO25IN		4 ⁽¹⁾	2	
$V_{LDODROP}$	Dropout ⁽²⁾	$V_{LDOOUT} = 2.9\text{ V}$, $I_{LDOOUT} = 350\text{ mA}$		180	300	mV
$V_{LDOOUT-LO}$	Load transient regulation	$I_{LDOOUT} = 1\text{ mA}$ to 180 mA , $t_R = t_F = 1\ \mu\text{s}$		35		
$V_{LDOOUT-LI}$	Line transient regulation	$V_{LDOIN} = 4.5\text{ V}$ to 5 V , $t_R = t_F = 10\ \mu\text{s}$, $\Delta I_{LDOOUT} = 0$		10		
P_{SRRLDO}	Power supply rejection ratio	$\Delta V_{LDOIN} = 300\text{ mVPP}$, $f = [0.1:20]\text{ kHz}$, $T_j = 25\text{ }^\circ\text{C}$, $I_{LDOOUT} = 200\text{ mA}$		43		dB
			$\Delta V_{LDOIN} = 300\text{ mVPP}$, $f = [20:100]\text{ kHz}$, $T_j = 25\text{ }^\circ\text{C}$, $I_{LDOOUT} = 200\text{ mA}$		37	
t_{SSLDO}	Soft-start duration	$2.8\text{ V} < V_{LDOIN} < 5.5\text{ V}$, $0 < I_{LDOOUT} < 1\text{ mA}$ $C_{OUT} = 4.7\ \mu\text{F}$, $V_{LDOOUT} = 3.3\text{ V}$		160 ⁽³⁾		μs
$V_{LDOOUT-SO}$	Startup overshoot	$2.8\text{ V} < V_{LDOIN} < 5.5\text{ V}$, $1.7\text{ V} < V_{LDOOUT} < 3.3\text{ V}$ $I_{LDOOUT} < 10\ \mu\text{A}$		1		%
t_{SDLDO}	Shutdown duration	Pull-down enabled, $V_{LDOOUT} =$ from 3.3 V to 0.2 V , $I_{LDOOUT} =$ no load			1.5	ms

 1. $V_{IN} = V_{LDOIN} = 5\text{ V}$, $T_j = 25\text{ }^\circ\text{C}$

2. Dropout is the smallest difference between a regulator's input and its output voltage, which is required to maintain regulation and enable the regulator to provide rated voltage and current

 3. Value can be impacted by current limitation and V_{OUT} and C_{OUT} values

3.4.4 LDO3
Table 10. Electrical and timing parameter specifications (LDO3)

Symbol	Parameter	Test conditions	Min.	Typ.	Max.	Unit
LDO3 normal mode						
V_{LDOIN}	Main input voltage range		2.8		5.5	V
V_{LDOOUT}	Output voltage	$V_{LDOIN} > V_{LDOOUT} + V_{LDODROP}$ programmable value.		0.9 to 4.0		
		Voltage programming step		100		mV
$V_{LDOOUT-ACC}$	Output voltage accuracy	$2.8\text{ V} < V_{LDOIN} < 5.5\text{ V}$, $1.7\text{ V} < V_{LDOOUT} < 3.3\text{ V}$ $100\text{ }\mu\text{A} < I_{LDOOUT} < 120\text{ mA}$	-2		+2	%
I_{LDOLIM}	Output current limitation	$2.8\text{ V} < V_{LDOIN} < 5.5\text{ V}$	120		180	mA
I_{LDOQ}	Total quiescent current	$I_{LDOOUT} = 0\text{ mA}$		7 ⁽¹⁾	13	μA
I_{LDOIN_LKG}	Input leakage current	LDO output disabled, $T_j = 25\text{ }^\circ\text{C}$		1	3	
$V_{LDODROP}$	Dropout voltage	$V_{LDOOUT} = 3.3\text{ V}$, $I_{LDOOUT} = 100\text{ mA}$		120	200	mV
$V_{LDOOUT-LO}$	Load transient regulation	$I_{LDOOUT} = 100\text{ }\mu\text{A}$ to 50 mA , $t_R = t_F = 1\text{ }\mu\text{s}$		20		
$V_{LDOOUT-LI}$	Line transient regulation	$V_{LDOIN} = 4.5\text{ V}$ to 5 V , $t_R = t_F = 10\text{ }\mu\text{s}$. $\Delta I_{LDOOUT} = 0$		5		
P_{SRRLDO}	Power supply rejection ratio	$\Delta V_{LDOIN} = 300\text{ mV}_{PP}$, $f = [0.1:20]\text{ kHz}$, $T_j = 25\text{ }^\circ\text{C}$, $I_{LDOOUT} = 50\text{ mA}$		45		dB
		$\Delta V_{LDOIN} = 300\text{ mV}_{PP}$, $f = [20:100]\text{ kHz}$, $T_j = 25\text{ }^\circ\text{C}$, $I_{LDOOUT} = 50\text{ mA}$		40		
t_{SSLDO}	Soft-start duration	$2.8\text{ V} < V_{LDOIN} < 5.5\text{ V}$, $0 < I_{LDOOUT} < 1\text{ mA}$ $C_{OUT} = 4.7\text{ }\mu\text{F}$, $V_{OUT} = 1.8\text{ V}$		160 ⁽²⁾		μs
$V_{LDOOUT-SO}$	Startup overshoot	$2.8\text{ V} < V_{LDOIN} < 5.5\text{ V}$, $1.7\text{ V} < V_{LDOOUT} < 3.3\text{ V}$, $I_{LDOOUT} < 10\text{ }\mu\text{A}$		1		%
t_{SDLDO}	Shutdown duration	Pull-down enabled, $V_{LDOOUT} = 3.3\text{ V}$ to $V_{LDOOUT} = 0.2\text{ V}$, $I_{LDOOUT} = \text{no load}$			1.5	ms
LDO3 sink-source mode (DDR VTT supply)						
$V_{LDOIN}=V_{OUT6} = 1.35\text{ V}$, $V_{IN} = 5.0\text{ V}$, $V_{BUCK2IN} = 5.0\text{ V}$, $V_{LDOOUT} = V_{OUT2}/2$, $T_j = -40\text{ }^\circ\text{C}$ to $+125\text{ }^\circ\text{C}$, recommended BOM, unless otherwise specified						
$V_{LDOIN-SS}$	Input voltage range		1.1	1.2	1.6	V
$V_{LDOOUT-SS}$	Output voltage			$V_{OUT2}/2$		
$V_{LDOOUT-ACC-SS}$	Output voltage accuracy	$1.1\text{ V} < V_{LDOIN} < 1.6\text{ V}$, $-215\text{ mA} < I_{LDOOUT} < +215\text{ mA}$	-1.5		+1.5	%
$I_{LDOOUT-SS}$	Continuous output current	$1.1\text{ V} < V_{LDOIN} < 1.6\text{ V}$			120	mA_{RMS}
$I_{LDOLIM-SS}$	Output current limitation	$V_{LDOIN} = 1.1\text{ V}$ to 5.5 V	± 230		± 500	mA
$I_{LDOQ-SS}$	Total quiescent current	$I_{LDOOUT} = 0\text{ mA}$, measured from LDO3IN pin		4 ⁽¹⁾	20	μA
$V_{LDOOUT-LO-SS}$	Load transient regulation	$I_{LDOOUT} = \pm [0:50]\text{ mA}$, $t_R = t_F = 250\text{ ns}$		30		mV
$V_{LDOOUT-LI-SS}$	Line transient regulation	$V_{LDOIN} = V_{OUT2} = 1.35\text{ V} \pm 30\text{ mV}$, $t_R = t_F = 10\text{ }\mu\text{s}$		5		
$t_{SSLDO-SS}$	Soft-start duration	$1.1\text{ V} < V_{LDOIN} < 1.6\text{ V}$, $ I_{LDOOUT} < 1\text{ mA}$, $C_{OUT} = 10\text{ }\mu\text{F}$		20	40	μs
t_{SU_LDO}	Startup delay (delay before voltage starts to rise)	controlled by a PWRCTRLx. PWRCTRL delay = 0		16	20	μs

Symbol	Parameter	Test conditions	Min.	Typ.	Max.	Unit
$V_{LDOOUT-SO-SS}$	Startup overshoot	$1.1\text{ V} < V_{LDOIN} < 1.6\text{ V}$, $V_{LDOOUT} = V_{OUT2}/2$, $I_{LDOOUT} = 10\ \mu\text{A}$			4	%
$t_{SDLDO-SS}$	Shutdown duration	Pull-down enabled, $V_{LDOOUT} = V_{out2}/2$ to $V_{LDOOUT} = 0.2\text{ V}$, $I_{LDOOUT} = \text{no load}$			1.5	ms

- $V_{IN} = V_{LDOIN} = 5\text{ V}$, $T_j = 25^\circ\text{C}$
- Value can be impacted by V_{OUT} and C_{OUT} values.

3.4.5 LDO4

Table 11. Electrical and timing parameter specifications (LDO4)

Symbol	Parameter	Test conditions	Min.	Typ.	Max.	Unit
LDO4						
V_{LDOIN}	Main input voltage range	V_{LDOIN} from V_{IN}	2.8		5.5	V
$V_{LDOOUT-ACC}$	Output voltage accuracy	$V_{LDOIN} = 3.6\text{ V to } 5.5\text{ V}$ $100\ \mu\text{A} < I_{LDOOUT} < 30\text{ mA}$	3.23	3.3	3.40	
I_{LDOLIM}	Output current limitation	$V_{LDOIN} = 3.6\text{ V to } 5.5\text{ V}$	50	75	200	mA
I_{LDOQ}	Quiescent current	$I_{LDOOUT} = 0\text{ mA}$		20 ⁽¹⁾	25	μA
$V_{LDODROP}$	Dropout voltage from V_{IN} pin	$I_{LDOOUT} = 30\text{ mA}$		45	90	mV
$V_{LDOOUT-LO}$	Load transient regulation	$I_{LDOOUT} = 1\text{ to } 30\text{ mA}$, $t_R = t_F = 1\ \mu\text{s}$		40		
$V_{LDOOUT-LI}$	Line transient regulation	$V_{IN} = 4.5\text{ V to } 5.0\text{ V}$, $I_{LDOOUT} = 0\text{ mA}$, $\Delta I_{LDOOUT} = 0$		10		
P_{SRRLDO}	Power supply rejection ratio	$\Delta V_{LDOIN} = 300\text{ mVPP}$, $f = [0.1:20]\text{ kHz}$, $T_j = 25^\circ\text{C}$, $I_{LDOOUT} = 25\text{ mA}$		55		dB
		$\Delta V_{LDOIN} = 300\text{ mVPP}$, $f = [20:100]\text{ kHz}$, $T_j = 25^\circ\text{C}$, $I_{LDOOUT} = 25\text{ mA}$		40		
t_{SSLDO}	Soft-start duration	$3.6\text{ V} < V_{LDOIN} < 5.5\text{ V}$, $0 < I_{LDOOUT} < 1\text{ mA}$, $C_{OUT} = 4.7\ \mu\text{F}$		100 ⁽²⁾		μs
$V_{LDOOUT-SO}$	Startup overshoot	$3.6\text{ V} < V_{LDOIN} < 5.5\text{ V}$, $I_{LDOOUT} < 10\ \mu\text{A}$		1		%
t_{SDLDO}	Shutdown duration	Pull-down enabled, $V_{LDOOUT} = 3.3\text{ V}$ to $V_{LDOOUT} = 0.2\text{ V}$, $I_{LDOOUT} = \text{no load}$			1.5	ms

- $V_{IN} = V_{LDOIN} = 3.6\text{ V}$, $T_j = 25^\circ\text{C}$.
- Value can be impacted by C_{OUT} values.

3.4.6 BUCK1
Table 12. Electrical and timing parameter specifications (BUCK1)

Symbol	Parameter	V _{OUT} range	Test conditions	Min.	Typ.	Max.	Unit
BUCK1 (LV and HV)							
V _{BUCKIN}	Main input voltage range			2.8		5.5	V
V _{OUT}	Output voltage	LV	Programmable value		0.5 to 1.5		V
			Voltage programming step		10		mV
		HV	V _{BUCKIN} > V _{OUT} + V _{BUCKDROP} Programmable value		1.5 to 4.2		V
			Voltage programming step		100		mV
V _{OUT-ACC}	Output voltage error amplifier accuracy	LV	0.5 V < V _{OUT} < 1.5 V	-1.5		1.5	%
		HV	1.5 V < V _{OUT} < 4.2 V	-1.5		1.5	
V _{OUT-REG}	Output load regulation ⁽⁴⁾	HV/LV	CCM mode 1 mA < I _{OUT} < 1.5 A	-1		1	
V _{OUT-RIPP}	Output voltage ripple ⁽²⁾	LV	3.0 V < V _{BUCKIN} < 5.5 V 0.5 V < V _{OUT} < 1.5 V		10		mVpp
		HV	2.8 V < V _{BUCKIN} < 5.5 V 1.5 V < V _{OUT} < 4.2 V,		15		
I _{OUT}	Max output current ⁽⁴⁾		2.8 V < V _{BUCKIN} < 5.5 V Programmable value in NVM_BUCKS_IOUT_SHR1	500 1000 1500 2000			mA
I _{BCKLIM}	Inductor peak current limit		Depends on NVM_BUCKS_IOUT_SHR1 Max output current steps (0.5 A, 1 A, 1.5 A, 2 A) can be defined based on the selected inductor peak current limit level		1.5 2.1 2.8 3.3		A
f _{REFCLK}	Reference switching frequency				2		MHz
I _{Q_BCK}	Total quiescent current		I _{OUT} = 0 mA		115	300	μA
I _{BUCKIN_LKG}	Input leakage current		BUCK OFF, T _j = + 25 °C		0.01	1	μA
EFF _{BCK}	Efficiency	V _{BUCKIN} = 5 V, V _{OUT} = 1.25 V, T _j = +50 °C					%
		I _{OUT} = 10 mA			81		
		I _{OUT} = 100 mA			83		
		I _{OUT} = 300 mA			84		
		I _{OUT} = 1000 mA			82		
I _{OUT} = 2000 mA			76				
V _{OUT-LO}	Load transient regulation ⁽¹⁾	LV	3.0 V < V _{BUCKIN} < 5.5 V 1.2 V < V _{OUT} < 1.4 V (typ 1250 mV) 5 mA < I _{OUT} < 1.5 A ΔI _{OUT} = 450 mA, t _R /t _F = 1μs			+/-34	mV

Symbol	Parameter	V _{OUT} range	Test conditions	Min.	Typ.	Max.	Unit
V _{OUT-LO}	Load transient regulation ⁽¹⁾	HV	3.0 V < V _{BUCKIN} < 5.5 V 1.8 V < V _{OUT} < 3.3 V 5 mA < I _{OUT} < 2 A ΔI _{OUT} = 500 mA, t _R = t _F = 1 μs ΔV(in-out) > 1.5 V			50	mV
V _{OUT-LI}	Line transient regulation		ΔV _{BUCKIN} = 600 mV, t _R = t _F = 10 μs, I _{OUT} = 300 mA, ΔV(in-out) > 1.5 V		5		mV
V _{OUT-OVR}	Power-up overshoot		2.8 V < V _{BUCKIN} < 5.5 V, I _{OUT} = 1 mA T _A = +25°C, 0.5 V < V _{OUT} < 4.2 V		10		mV
t _{NORM-CCM-BCK}	Recovery time from Normal to Forced CCM mode		V _{OUT_Norm} = V _{OUT_CCM} , controlled by a PWRCTRLx			40 ⁽⁴⁾	μs
t _{SU_BCK}	Start-up delay (delay before voltage starts to rise)		2.8 V < V _{BUCKIN} < 5.5 V, controlled by a PWRCTRLx		25 ⁽³⁾	40 ⁽⁴⁾	μs
t _{SS_BCK}	Soft-start duration	LV		200		1500	μs
		HV		320		1500	
SR _{BCK}	Output voltage slew rate	LV	Slew rate during start-up	1		12.5	mV/μs
		HV	Slew rate during start-up	2.8		12.5	
			DVS slew rate of a voltage programmed change low to high or high to low, from V _{OUT} = 0.5 V to 1.5 V (LV) or V _{OUT} = 1.5 V to 4.2 V (HV)	1	3.1		
t _{SD_BCK}	Shutdown duration	LV	From V _{OUT} = 1.5 V to V _{OUT} < 0.2 V 2.8 V < V _{BUCKIN} < 5.5 V, I _{OUT} < 1 mA				ms
			Slow PD			1.5	
			Fast PD			0.3	
		HV	From V _{OUT} = 4.2 V to V _{OUT} < 0.2 V 2.8 V < V _{BUCKIN} < 5.5 V, I _{OUT} < 1 mA				
			Slow PD			1.5	
			Fast PD			0.3	

1. Guaranteed by design - not tested in production. Load transient performances are strongly impacted by the external passive component characteristics. The load transient is also influenced by the parasitic elements of the PCB layout.
2. The output ripple voltage is the result of the inductor ripple current flowing through the output capacitor and depends on the capacitance value, ESR, and ESL. The actual output ripple voltage is also influenced by the parasitic elements of the PCB layout.
3. See 1: startup sequence.
4. Guaranteed by design - not tested in production.

3.4.7 BUCK2

Table 13. Electrical and timing parameter specifications

Symbol	Parameter	Test conditions	Min.	Typ.	Max.	Unit
BUCK2						
V _{BUCKIN}	Main input voltage range		2.8		5.5	V

Symbol	Parameter	Test conditions	Min.	Typ.	Max.	Unit
V _{OUT-ACC}	Output voltage error amplifier accuracy	Programmable value		0.5 to 1.5		V
		Voltage programming step		10		mV
		0.5 V < V _{OUT} < 1.5 V	-1.5		1.5	%
		1.0 V < V _{OUT} < 1.35 V	-1		1	
V _{OUT-REG}	Output load regulation ⁽⁴⁾	CCM mode 1 mA < I _{OUT} < 1.5 A	-1		1	
V _{OUT-RIPP}	Output voltage ripple ⁽²⁾	3.0 V < V _{BUCKIN} < 5.5 V 50 mA < I _{OUT} < 1000 mA, 1.0 V < V _{OUT} < 1.35 V		10		mVpp
I _{OUT}	Max output current ⁽⁴⁾	3.0 V < V _{BUCKIN} < 5.5 V Programmable value in NVM_BUCKS_IOUT_SHR1	500 1000 1500 2000			mA
I _{BCKLIM}	Inductor peak current limit	Depends on NVM_BUCKS_IOUT_SHR1 Max output current steps (0.5 A, 1 A, 1.5 A, 2 A) can be defined based on the selected Inductor peak current limit level		1.5 2.1 2.8 3.3		A
f _{REFCLK}	Reference switching frequency			2		MHz
I _{Q_BCK}	Total quiescent current	I _{OUT} = 0 mA		115	300	μA
I _{BUCKIN_LKG}	Input leakage current	BUCK OFF, T _j = +25 °C		0.01	1	μA
EFF _{BCK}	Efficiency	V _{BUCKIN} = 5 V, V _{OUT} = 1.2 V, T _j = +50 °C				%
		I _{OUT} = 10 mA		79		
		I _{OUT} = 100 mA		81		
		I _{OUT} = 300 mA		81		
		I _{OUT} = 1000 mA		80		
		I _{OUT} = 1500 mA		77		
V _{OUT-LO}	Load transient regulation ⁽⁴⁾	3.0 V < V _{BUCKIN} < 5.5 V 5 mA < I _{OUT} < 1.0 A ΔI _{OUT} = 450 mA, t _R = t _F = 500 ns			+/-30	mV
V _{OUT-LI}	Line transient regulation	ΔV _{BUCKIN} = 600 mV, t _R = t _F = 10 μs ΔI _{OUT} = 0		5		mV
V _{OUT-OVR}	Power-up overshoot	2.8 V < V _{BUCKIN} < 5.5 V, I _{OUT} = 1 mA, T _A = +25°C		10		mV
t _{NORM-CCM-BCK}	Recovery time from Normal to Forced CCM mode	V _{OUT_Norm} = V _{OUT_CCM} controlled by a PWRCTRLx			40	μs
t _{SU_BCK}	Start-up delay (delay before voltage starts to rise)	2.8 V < V _{BUCKIN} < 5.5 V controlled by a PWRCTRLx		25 ⁽³⁾	40 ⁽⁴⁾	μs
t _{SS_BCK}	Soft-start duration	2.8 V < V _{BUCKIN} < 5.5 V 1 mA < I _{OUT} < 100 mA V _{OUT} = 1.5 V	330		1500	μs

Symbol	Parameter	Test conditions	Min.	Typ.	Max.	Unit
SR _{BCK}	Output voltage slew rate	Slew rate during start-up	1		4.40	mV/μs
		DVS slew rate of a voltage programmed change low to high or high to low, from V _{OUT} = 0.5 V to 1.5 V	1	3.1		
t _{SD_BCK}	Shutdown duration	From V _{OUT} = 1.5 V to V _{OUT} < 0.2 V 2.8 V < V _{BUCKIN} < 5.5 V, I _{OUT} < 1 mA				ms
		Slow PD			1.5	
		Fast PD			0.3	

1. *Guaranteed by design - not tested in production. Load transient performances are strongly impacted by the external passive component characteristics. The load transient is also influenced by the parasitic elements of the PCB layout. For more information, see AN6116.*
2. *The output ripple voltage is the result of the inductor ripple current flowing through the output capacitor and depends on the capacitance value, ESR, and ESL. The actual output ripple voltage is also influenced by the parasitic elements of the PCB layout.*
3. *See 1: startup sequence.*
4. *Guaranteed by design - not tested in production.*

4 Power regulator descriptions

4.1 Overview

The STPMIC1L has a wide input voltage range from 2.8 V to 5.5 V to supply applications typically by a 5 V DC wall-adaptor or a 1-cell 3.6 V Li-Ion / Li-PO battery.

The STPMIC1L provides all the regulators needed to power supply a STM32MP1x MPU, a DDR and a flash memory:

- 4 LDOs
- 2 step-down (buck) converters

Table 14. General description

Regulator	Output voltage (V)	Programming step (mV)	Rated output current (mA)	Application use
LDO2, LDO5	0.9 V to 4.0 V	100	400/200/100/50	General-purpose (eMMC, SD card)
LDO3 normal mode	0.9 V to 4.0 V	100	120	General-purpose / lpDDR VDD1
LDO3 sink-source mode	$V_{OUT2}/2$	-	+/-120 (rms) +/-230 (peak)	DDR3L/DDR4 terminations (VTT)
LDO4	3.3	-	40	STM32MP1x USB PHY
BUCK1	LV: 0.5 V to 1.5 V	10	2000, 1500, 1000, 500	Buck1 = VDDCORE
	HV: 1.5 V to 4.2 V	100		
BUCK2	0.5 V to 1.5 V	10	2000, 1500, 1000, 500	Buck2 = VDDQ (DDR3L, DDR4, lpDDR3, lpDDR4)
GPO1, GPO2				External Control 1, 2

4.2 LDO regulators

LDO2 and LDO5 are general-purpose LDOs suitable for supplying MPU application peripherals.

LDO3 serves for DDR3, DDR3L, DDR4 memory termination (sink-source mode) or to support the general-purpose mode, which is typically suitable for supplying lpDDR3 or lpDDR4.

LDO4 is a fixed 3.3 V regulator designed to supply a 3V3 USB PHY circuit.

4.2.1 LDO Common features

Enable/disable - each LDO can be enabled or disabled independently:

- Automatically during the POWER_UP or POWER_DOWN sequence depending on the NVM settings.
- By software (I²C access): Setting the EN bit in the related LDO control register.
- By PWRCTRLx pins state change: The PWRCTRLx pins need to be programmed by I²C to enable this feature.

VLDO OUT voltage setting - LDO output voltage can be set:

- Automatically during the POWER_UP or POWER_DOWN sequence depending on the NVM settings.
- By software (I²C access): Setting the V_{OUT} bit field in the related LDO control register.
- By PWRCTRLx pins state change: The PWRCTRLx pins need to be programmed by I²C to select the necessary output voltages to meet the MPU application requirements.

The LDO can be enabled or disabled as in normal operation. See the “**Enable/ disable**” description above.

Soft start: This feature aims to limit input inrush current during the LDO startup phase. LDO soft-start duration is defined by the t_{SSLDO} parameter.

See Figure 3.

Figure 3. LDO startup/shutdown timings

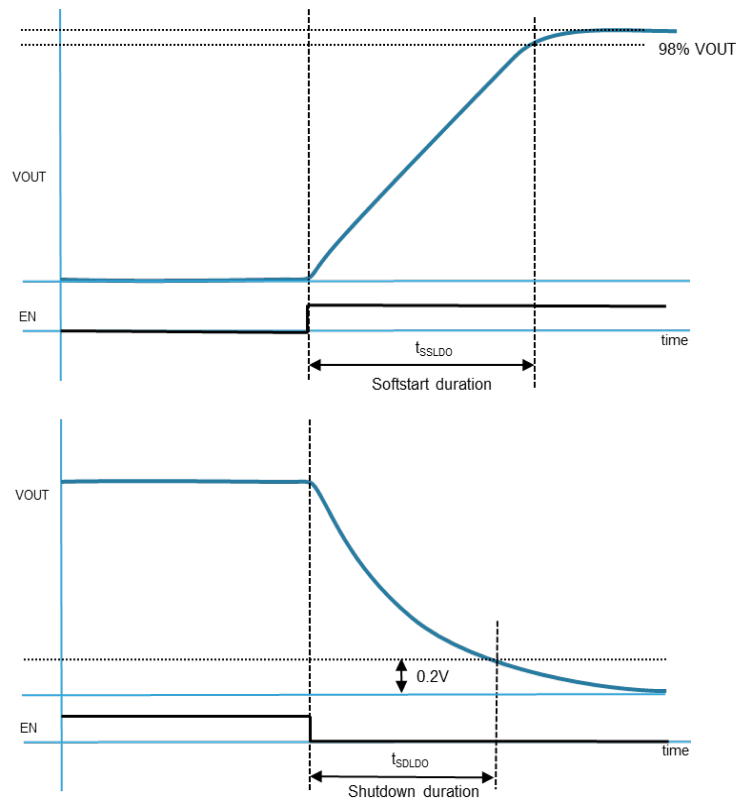

Output discharge: When LDO is disabled, a pull-down discharge is automatically enabled. It allows the LDO output voltage to discharge within a t_{SDLDO} time delay. The LDO output is low before disabling the next regulators in the next ranking slot. It is active by default. It can be disabled by software to put the LDO output in high impedance when LDO is disabled (LDOS_PD_CR register).

OCP and Hiccup management: Each LDO supports OCP and can operate in Hiccup mode. When the output load of the LDO exceeds the I_{LDOLIM} overcurrent limit threshold, the LDO starts decreasing the output voltage, limiting the output current to I_{LDOLIM}. If the overcurrent lasts more than t_{OCPDB_LDO}:

- An interrupt is generated (if the interrupt has been unmasked by software)
- Hiccup mode (default behavior): The LDO is turned OFF for the $t_{\text{HICCUP_DLY}}$ duration and then turned ON again.
- Fail-safe mode (alternative behavior): The PMIC is turned OFF for the $t_{\text{HICCUP_DLY}}$ duration and then turned ON again (or goes into FAIL_SAFE_LOCK state)

See Section 5.4.15 for details on OCP & Hiccup management.

LDO2 and LDO5 have programmable I_{LDOLIM} overcurrent limit thresholds. I_{LDOLIM} thresholds are programmed in the NVM_LDOS_IOUT_SHR NVM register.

4.2.2 LDO3 special features

The LDO3 is a multipurpose LDO with two operating modes:

- **Normal mode** – LDO3 works as a general-purpose LDO as well as LDO2, 5.
- **Sink-source mode** – LDO3 can regulate the output voltage working in sink source mode. This mode is dedicated to supplying the termination of DDR3/DDR3L or DDR4 IC memories with fixed output voltage. If LDO3 is used in this mode, LDO3IN must be powered from the output of BUCK2 (See Figure 6). The output voltage is fixed and follows VOUT2/2 even during the BUCK2 ramp-up and ramp-down phases. The overcurrent limitation works both during sink and source output current modes.

4.2.3 LDO4 special features

LDO4 can be dedicated to supply a USB HS analog PHY power domain.

The LDO4 output voltage is fixed at 3.3 V.

4.2.4 LDO output voltage settings

Table 15. LDO output voltage settings

	VOUT [4:0] (decimal)	VOUT [V] LDO2 / LDO3 (normal mode) / LDO5
Step 100 mV	0	0.9
	1	1.0
	2	1.1
	3	1.2
	4	1.3
	5	1.4
	6	1.5
	7	1.6
	8	1.7
	9	1.8
	10	1.9
	11	2.0
	12	2.1
	13	2.2
	14	2.3
	15	2.4
	16	2.5
	17	2.6
	18	2.7
	19	2.8

	VOUT [4:0] (decimal)	VOUT [V] LDO2 / LDO3 (normal mode) / LDO5
Step 100 mV	20	2.9
	21	3.0
	22	3.1
	23	3.2
	24	3.3
	25	3.4
	26	3.5
	27	3.6
	28	3.7
	29	3.8
	30	3.9
	31	4.0

4.2.5 Examples of DDR memory power supply topology using LDOs

Figure 4. LDO3 uses in sink/source mode with DDR3L

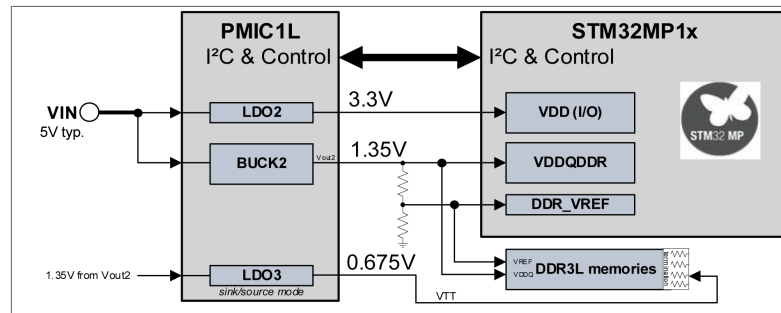
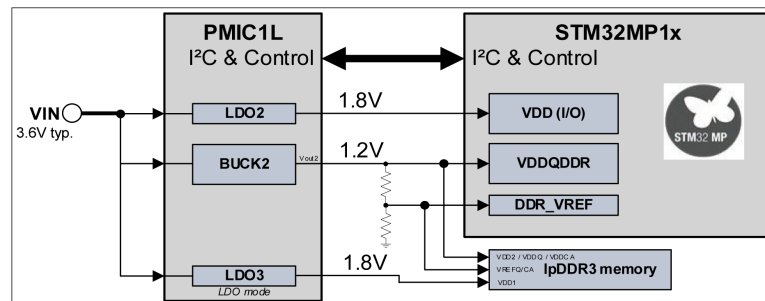

Figure 5. LDO3 uses in LDO mode with IpDDR3



4.3 Buck converters

General description

The STPMIC1L includes two buck converters that are optimized to supply circuits with high current consumption and meet fast transient response requirements.

All converters are based on an adaptive constant-on-time controller (COT) that guarantees an excellent transient response and high efficiency across a wide range of operating conditions.

The switching frequency of the converter is typically 2 MHz in a steady-state CCM condition. In a typical MPU application:

- BUCK1 is primarily dedicated to supplying power to the VDDCORE domain.
- BUCK2 is primarily dedicated to supplying power to the VDDQDDR domain.

4.3.1 Buck converters common features

Enable/Disable: each buck converter can be enabled or disabled independently (same behavior as LDO: see Section 4.2.1)

V_{OUT} voltage setting: Output voltage can be set:

- Automatically during a POWER_UP or POWER_DOWN sequence depending on the NVM settings.
- By software (I²C access): Setting the V_{OUT} bit field in the related buck control register.
- By PWRCTRLx pins state change: The BUCKx converter behaves according to BUCKx_MAIN_CR and BUCKx_ALT_CR content setting. BUCKx_MAIN_CR or BUCKx_ALT_CR is selected by the PWRCTRL pin allocated to BUCKx (see section Section 5.4.10 (PWRCTRLx)).

Forced PWM mode (CCM mode): Each buck can be forced to work in PWM mode to keep a constant frequency and low ripple.

Normal and forced PWM modes are activated by the two-bit PREG_MODE [1:0] register as follows:

- 00: Normal (or auto mode)
- 01: Reserved
- 10: Forced PWM (CCM)
- 11: Reserved

Clock synchronization and clock phase shifting: When all buck converters work in a steady state in CCM mode, they are synchronized to a clock and are shifted by 180° in the following order:

- 0°: BUCK1
- 180°: BUCK2

Note: It is possible to force synchronization phase shifting for all buck converters by setting them to forced PWM (CCM). This improves EMI and avoids peak current on the main power supply input source.

Dynamic voltage scaling (DVS): When the buck output voltage is increased/decreased dynamically by the software, the buck output voltage (V_{OUT}) is stepped up/down following the S_{RBK} slew rate.

When a lower V_{OUT} is set, part of the buck converter output energy is discharged from the output capacitor following the S_{RBK} slew rate, providing current back to the input supply capacitor. This operation improves the total power efficiency.

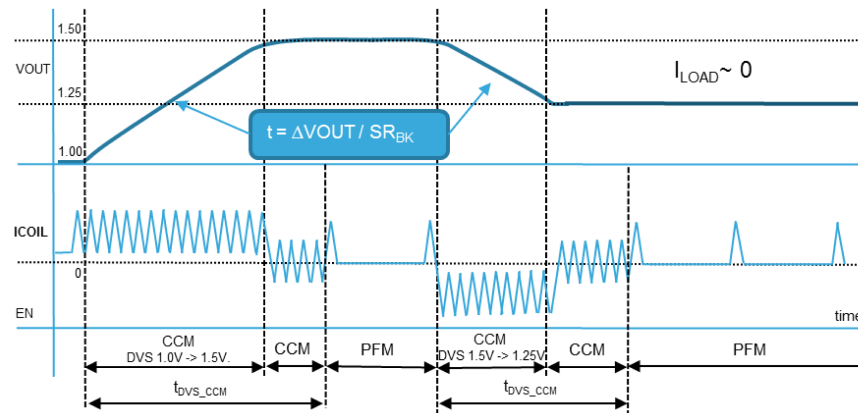
Figure 6. Buck dynamic voltage scaling (DVS)

OCP and Hiccup management: Each buck converter supports OCP and can operate in Hiccup mode. When the output load of the buck exceeds the I_{OUT} max output current (related to inductor peak current limit threshold $I_{BK(LIM)}$), the PWM pulse is immediately stopped, and the buck starts to decrease the output voltage, limiting the output current. If the overcurrent lasts more than t_{OCPDB_BUCK} :

- An interrupt is generated (if the interrupt has been unmasked by software).
- Default behavior: The buck is turned OFF for t_{HICCUP_DLY} duration and then turned ON again.
- Alternative behavior: The PMIC is turned OFF for t_{HICCUP_DLY} duration and then turned ON again (or goes to FAIL_SAFE_LOCK state).

See [Section 5.4.15](#) for details on OCP & hiccup management.

All buck converters have a programmable I_{OUT} max current threshold. I_{OUT} thresholds are programmed in the NVM_BUCKS_IOUT_SHR NVM register.

Output discharge: When the buck is disabled, a configurable pull-down (PD) discharge is automatically enabled. The buck output voltage discharges in t_{SD_BKtime} duration (with typical recommended BOM) so that the buck converter output voltage is low before disabling the next regulators in the next ranking slot. Four values are configurable by software at runtime: no pull-down, slow-PD, fast-PD and forced slow-PD by setting BUCKS_PD_CR. Fast discharge output can be modified by software in fast-PD when the buck is disabled, or it can be disabled by software to configure the buck converter output to high impedance when it is disabled. See [Figure 7](#) which shows fast-PD and slow-PD behavior.

Startup sequence: When a buck is enabled, a startup delay (t_{SU_BCK}) occurs before the output voltage starts to rise, and is followed by a soft-start voltage ramp (t_{SS_BCK}). See [Figure 7](#).

Figure 7. Buck startup/shutdown timings

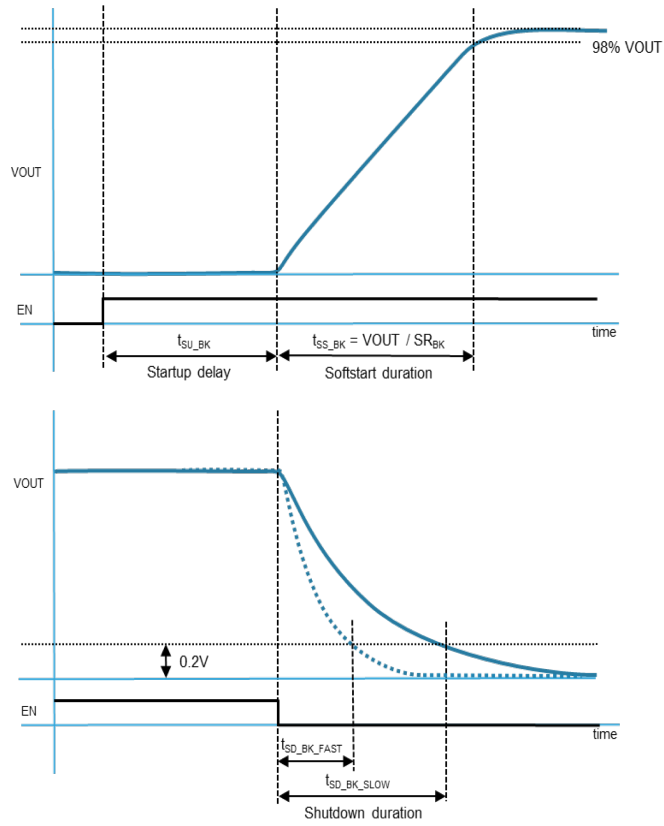

4.3.2 Buck output voltage settings

Table 16. Buck output voltage settings

	VOUT [6:0] (decimal)	V _{OUT} [V] BUCK1_LV and BUCK2	V _{OUT} [V] BUCK1_HV
Step 10 mV LV	0	0.50	1.5
	1	0.51	1.5
	2	0.52	1.5
	3	0.53	1.5
	4	0.54	1.5
	5	0.55	1.5
	6	0.56	1.5
	7	0.57	1.5
	8	0.58	1.5
	9	0.59	1.5
	10	0.60	1.5
	11	0.61	1.5
	12 to 94	...	1.5
	95	1.45	1.5
	96	1.46	1.5
	97	1.47	1.5
	98	1.48	1.5
99	1.49	1.5	
100	1.50	1.5	
Step 100 mV HV	101	1.50	1.6
	102	1.50	1.7
	103	1.50	1.8
	104	1.50	1.9
	105	1.50	2.0
	106	1.50	2.1
	107	1.50	2.2
	108	1.50	2.3
	109	1.50	2.4
	110	1.50	2.5
	111	1.50	2.6
	112	1.50	2.7
	113 to 122	1.50	...
	123	1.50	3.8
	124	1.50	3.9
	125	1.50	4.0
	126	1.50	4.1
127	1.50	4.2	

5 Feature descriptions

5.1 Functional state machine

Overview

STPMIC1L integrates advanced low-power features controlled by the application processor through I²C, four digital control pins (PONKEYn/EN, PWRCTRL1/2, and RSTn) and one interrupt output line (INTn).

The main parameter settings can be programmed in a non-volatile memory (NVM) as default values at the startup time. See [Section 5.2.2](#).

All regulators can be independently controlled from the PWRCTRLx pins. This allows for flexible configuration and a fast transition between different power strategies at the application level.

Other features are provided to fulfill high-end application processor and advanced operating system needs:

- Multiple turn-on/turn-off conditions
- Mask_reset and restart_request options
- Overcurrent and overvoltage protection
- Thermal protection
- Watchdog
- Interrupt controller
- Safety management

PMIC state machine - STPMIC1L state machine is described in [Figure 8](#).

Figure 8. PMIC state machine

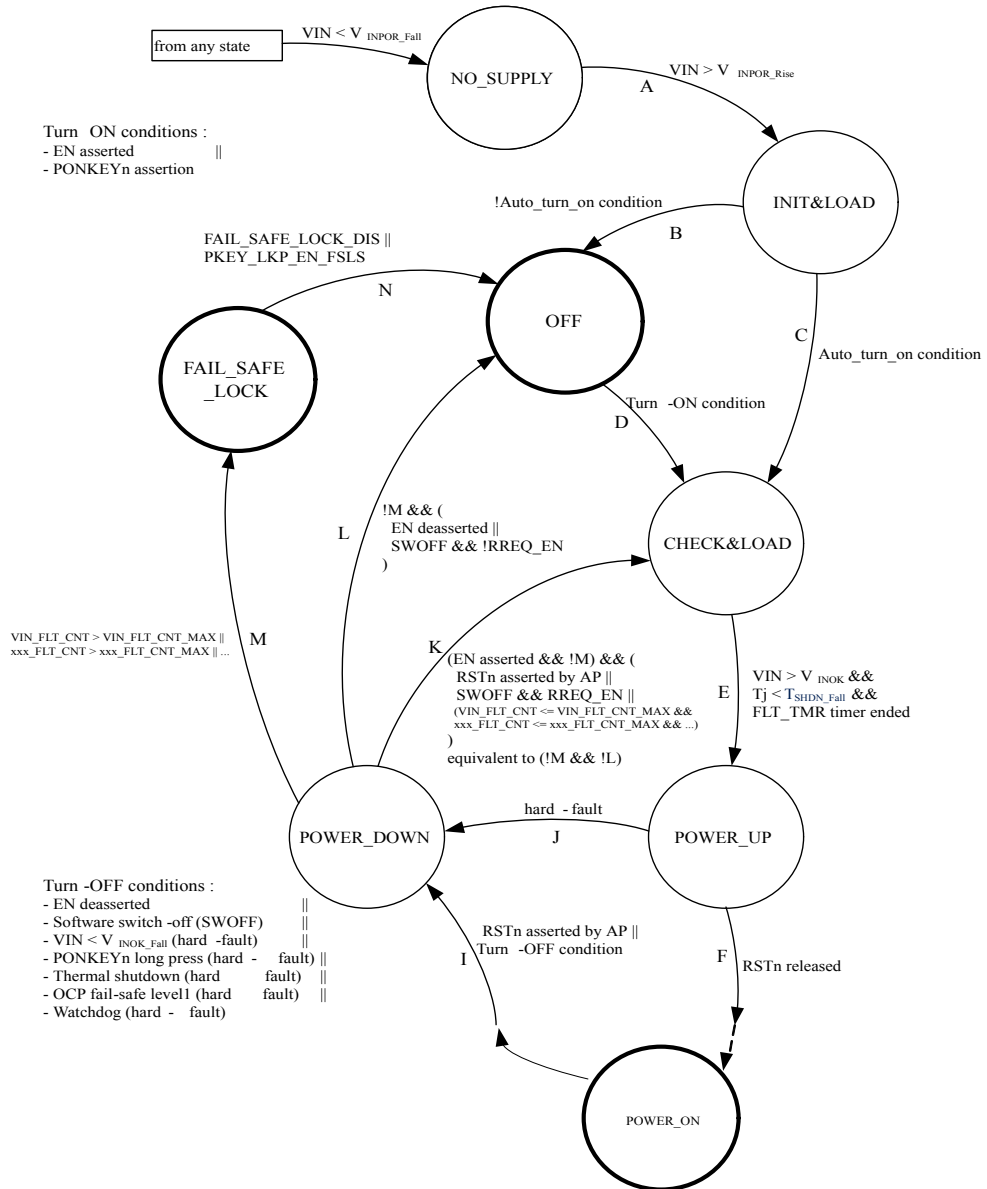

5.1.1 Transition conditions
Table 17. PMIC state machine transition conditions

Transition symbol	State transition	Transition condition
A	NO_SUPPLY to INIT&LOAD	$V_{IN} > V_{INPOR_Rise}$
B	INIT&LOAD to OFF	Not auto_turn_on condition: Init_OK && load NVM_OK && !(AUTO_TURN_ON PONKEYn_low EN deasserted)
C	INIT&LOAD to CHECK&LOAD	Auto_turn_on condition: Init_OK && load NVM_OK && (AUTO_TURN_ON PONKEYn_low EN_asserted)
D	OFF to CHECK&LOAD	Turn-on condition: PONKEYn falling edge EN asserted
E	CHECK&LOAD to POWER_UP	CHECK&LOAD is a transitory state going to POWER_UP: $V_{IN} > V_{INOK}$ && $T_j < T_{SHDN_Fall}$ && FLT_TMR timer ended
F	POWER_UP to POWER_ON	When power-up sequence ends without hard-fault, the PMIC released RSTn, Transition F occurs when RSTn signal goes higher than V_{IH} .
I	POWER_ON to POWER_DOWN	EN deasserted RSTn signal asserted by AP Turn-off condition: Software switch-off (SWOFF) $V_{IN} < V_{INOK_Fall}$ (hard-fault) PONKEYn long press (hard-fault) Thermal shutdown (hard-fault) OCP fail-safe level1 (hard-fault) Watchdog (hard-fault)
J	POWER_UP to POWER_DOWN	Turn-off condition (hard-fault): $V_{IN} < V_{INOK_Fall}$ (hard-fault) PONKEYn long press (hard-fault) Thermal shutdown (hard-fault) OCP fail-safe level1 (hard-fault) Watchdog (hard-fault)
K	POWER_DOWN to CHECK&LOAD	(EN asserted && !M) RSTn asserted by AP (SWOFF && RREQ_EN) (VIN_FLT_CNT <= VIN_FLT_CNT_MAX && PKEY_FLT_CNT <= PKEY_FLT_CNT_MAX && TSHDN_FLT_CNT <= TSHDN_FLT_CNT_MAX && OCP_FLT_CNT <= OCP_FLT_CNT_MAX && WDG_FLT_CNT <= WDG_FLT_CNT_MAX)
L	POWER_DOWN to OFF	!M && (EN deasserted (SWOFF && !RREQ_EN))
M	POWER_DOWN to FAIL_SAFE_LOCK	VIN_FLT_CNT > VIN_FLT_CNT_MAX PKEY_FLT_CNT > PKEY_FLT_CNT_MAX TSHDN_FLT_CNT > TSHDN_FLT_CNT_MAX

Transition symbol	State transition	Transition condition
		OCP_FLT_CNT > OCP_FLT_CNT_MAX WDG_FLT_CNT > WDG_FLT_CNT_MAX
N	FAIL_SAFE_LOCK to OFF	Transition to force leaving the fail-safe locked state: FAIL_SAFE_LOCK_DIS (NVM bit) PKEY_LKP_EN_FSL (PONKEY Long Key Press Fail-Safe-Lock-Skip bit / EN deasserted Fail-Safe-Lock-Skip)

5.1.2 State explanations

5.1.2.1 **NO_SUPPLY**

V_{IN} is below V_{INPOR_Fall} (see Section 5.4.1). No output state can be guaranteed in this state.

5.1.2.2 **INIT&LOAD**

The INIT&LOAD state is immediately reached when V_{IN} is higher than V_{INPOR_Rise} .

STPMIC1L releases internal POR circuitry, it initializes, all registers are reset, the NVM load is performed (see Section 5.5.2), and RSTn is asserted.

If the Auto_turn_on condition is true, PMIC makes a transition to the CHECK&LOAD state. Prior to leaving the INIT&LOAD state, the TURN_ON_SR is reset, and then the TURN_ON_SR[AUTO] bit is set.

If the Auto_turn_on condition is false, STPMIC1L evaluates the PONKEYn/EN status. If the turn on condition is not recognized, STPMIC1L makes the transition to the OFF state, otherwise it sets the proper bit in TURN_ON_SR and makes the transition to the CHECK&LOAD state (see Table 17).

5.1.2.3 **OFF**

The OFF state is entered from the INIT&LOAD state, the POWER_DOWN state, or the FAIL_SAFE_LOCK state. In the OFF state, the PMIC is in the lowest power consumption state, and all regulators are turned OFF. The voltage references are OFF and RSTn is asserted by PMIC.

All fail-safe counters are reset (xxx_FLT_CNT). Fail-safe timers (FLT_TMR), reset-fault-counter-timers (RST_FLT_CNT_TMR), and watchdog timers are stopped.

The transition to the CHECK&LOAD state (see Table 17) is triggered by a turn-on condition (see Section 5.4.5).

Prior to leaving the OFF state, the TURN_ON_SR is reset, then the related turn-on condition bit is set in the TURN_ON_SR register.

5.1.2.4 **CHECK&LOAD**

CHECK&LOAD is a transitional state from a user point of view. It prepares the PMIC for power-up. The PMIC enables internal reference voltages, thermal monitoring, and V_{IN} monitoring.

The NVM is reloaded into shadow registers. Some registers are initialized with default values from the NVM content.

RSTn is asserted by the PMIC.

After the CHECK&LOAD state, the PMIC always transitions to the POWER-UP state if power-up conditions are fulfilled (see Table 17) and the fault timer (FLT_TMR) ends. The fault timer waits before restarting the PMIC after a hard-fault (see Section 5.2.2).

5.1.2.5 **POWER_UP**

The PMIC starts sequential regulators following a sequence that is predefined in the NVM and a default voltage that is predefined in the NVM (see).

During the power-up sequence, RSTn is asserted by the PMIC. When the power-up sequence ends without a hard-fault, the PMIC releases RSTn signal.

5.1.2.6 **POWER_ON**

In the **POWER_ON** state, the PMIC can be set to deliver power at full performance and features. Each regulator can switch power states (MAIN_CR or ALT_CR) depending on the PWRCTRLx pin settings (see Section 5.4.10).

5.1.2.7 POWER_DOWN

The PMIC asserts RSTn, then sequentially turns off the regulators starting with the regulators not enabled in the power-up sequence (= rank0: enabled by software at runtime), then in reverse sequence order in the POWER_UP state (see Section 5.2).

When the POWER_DOWN sequence ends, before the transition to the next state, the watchdog is disabled (WDG_EN = 0) and status registers are updated according to the turn-off condition source:

- TURN_ON_SR and TURN_OFF_SR and RESTART_SR and OCP_SR1 and OCP_SR2 are reset (cleared)
- If RSTn is asserted by AP (PMIC transition to K in Table 17):
 - RESTART_SR[R_RST] bit is set
- Else If SWOFF && RREQ_EN && PONKEYn set in NVM_MAIN_CTRL_SHR3 (PMIC transition to K in Table 17):
 - RESTART_SR[R_SWOFF] bit is set
- Else If SWOFF && EN asserted && EN set in NVM_MAIN_CTRL_SHR3 (PMIC transition to K in Table 17):
 - RESTART_SR[R_SWOFF] bit is set
- Else If EN asserted following a pulse deassertion on EN generating a turn-OFF condition (PMIC transition to K in Table 17):
 - RESTART_SR[R_EN] bit is set
- Else If SWOFF && !RREQ_EN (PMIC transition to L in Table 17):
 - TURN_OFF_SR[SWOFF] is set
- Else If EN deasserted (PMIC transition to L in Table 17):
 - TURN_OFF_SR[EN] is set
- Else (it is a hard-fault turn-off condition, then depending on the hard-fault source):
 - If hard-fault is OCP:
 - OCP_SR1 or OCP_SR2 is updated with the OCP fault source
 - If PMIC transitions to M:
 - TURN_OFF_SR is updated with fault source
 - If PMIC transitions to K:
 - RESTART_SR is updated with fault source

Note: If another turn-off condition is triggered during the POWER_DOWN sequence, it is ignored. So, only the original power-down trigger source is registered.

When a hard fault occurs first and EN feature is active, the choice between K and L transitions depends on EN status at end of POWER_DOWN sequence; in this scenario, TURN_OFF_SR/RESTART_SR are updated with both hard-fault source and EN bit, to keep trace of the original POWER_DOWN root cause.

5.1.2.8 FAIL_SAFE_LOCK

The FAIL_SAFE_LOCK state is entered from the POWER_DOWN state with an M transition (a hard-fault counter xxx_FLT_CNT that exceeds the max number of PMIC restart occurrences xxx_FLT_CNT_MAX).
In the FAIL_SAFE_LOCK state, the PMIC is in the lowest power consumption state: All regulators are turned OFF, voltage references are OFF, and RSTn is asserted by the PMIC.
The PMIC is locked in that state until POR: a turn-on condition does not power-up the PMIC.
Nevertheless, the PMIC is allowed to skip the FAIL_SAFE_LOCK state in specific N transition conditions (see Table 17).

5.2 POWER_UP / POWER_DOWN sequence

The PMIC starts and stops regulators following the sequential 5 rank procedures called POWER_UP and POWER_DOWN, respectively.

During POWER_UP each regulator is started at one of the 6-rank phases programmed in the NVM. Each rank phase is separated by a delay (1.5 ms, 3 ms, 4.5 ms, and 6 ms) programmed in the NVM.

An additional delay can be programmed in the NVM to release the RSTn signal later than the last rank phase. This delay is also applied after the Turn_OFF condition, in between RSTn signal assertion and when the first regulator is powered off (RANK0).

The default rank sequence for each regulator, default output voltage of each regulator, default rank duration, and additional RSTn default delays are predefined in the NVM. Those values can be adapted by reprogramming the PMIC NVM with expected values.

An additional VIN_DLY [1:0] delay (0, 10 ms, 50 ms, 100 ms) can be programmed in NVM to prevent the PMIC from powering up, allowing VIN to stabilize.

Figure 9. PMIC POWER_UP and POWER_DOWN sequence example

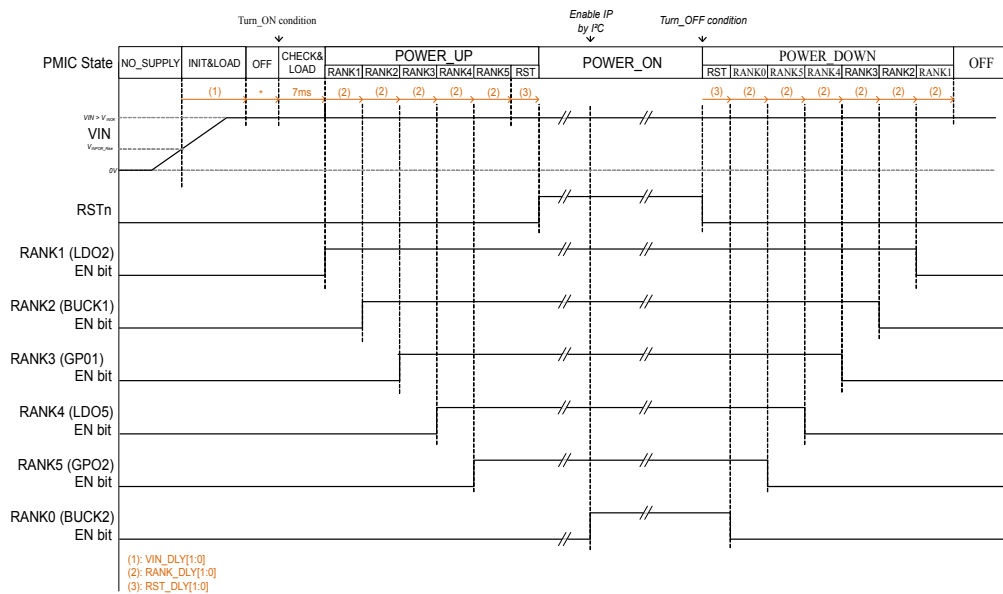

(*) The device remains in OFF state until a turn-on condition is triggered

For RANK_DLY and RST_DLY, see Table 80

Note: RANK0 means that the regulator is not turned ON during the POWER_UP sequence.

5.2.1 NO_SUPPLY and INIT&LOAD:

The PMIC is initially in NO_SUPPLY state with $VIN < VINPOR_Fall$. A power source is inserted making VIN rise. Once $VIN > VINPOR_Rise$, the PMIC goes into INIT&LOAD state. The PMIC reads NVM and performs internal initialization. Then, the PMIC launches the VIN_DLY [1:0] delay. Once the VIN_DLY elapses, the PMIC can transition to OFF state (or directly to CHECK&LOAD state if AUTO_TURN_ON bit is set in NVM).

The VIN_DLY is suitable when the PMIC starts immediately after VIN rise; especially when AUTO_TURN_ON bit is set in NVM.

5.2.2 OFF and CHECK&LOAD:

The PMIC is initially in the OFF state. The RSTn pin is asserted by the PMIC. Once a turn-on condition occurs, the PMIC goes into the CHECK&LOAD state. As the turn-on condition is valid (for example: $VIN > VINOK$) the PMIC goes into the POWER_UP state.

5.2.3 POWER_UP:

In the POWER_UP state, RSTn is kept asserted by the PMIC.

The PMIC enables regulators sequentially by 1.5 ms slots (according to the default rank sequence and default output voltage defined in the NVM, RANK_DLY[1:0]).

For example (see [Figure 9](#)):

RANK1 (LDO2) then RANK2 (BUCK1) then RANK3 (GPO1) then RANK4 (LDO5) then RANK5 (GPO2).

Once the RANK5 ends, the PMIC releases RSTn and then it goes into the POWER_ON state.

Note: Regulator RANK0 (LDO3 in this example) is not turned ON automatically.

5.2.4 POWER_ON:

In the POWER_ON state, all regulators are managed by the application processor's software (I²C control) or by the PWRCTRL pin (see [Section 5.4.10](#)). In the example of [Figure 9](#), BUCK2 is enabled by the AP's software at runtime.

5.2.5 POWER_DOWN:

Once a Turn-OFF condition occurs, the PMIC asserts RSTn, then the PMIC shuts down RANK0 regulators that have been started by software (BUCK2 in the [Figure 9](#) example).

Then the PMIC disables the regulators sequentially in reverse rank order from the POWER_UP sequence, by 1.5 ms slots (according to the default rank sequence in the NVM, RANK_DLY [1:0]).

For example (see [Figure 9](#)):

RANK5 (GPO2), then RANK4 (LDO5), then RANK3 (GPO1), then RANK2 (BUCK1), then RANK1 (LDO2).

When the RANK1 ends, the PMIC goes into the OFF state (RSTn is kept asserted). The analog behavior of regulators is detailed in [Section 4](#).

5.3 Digital pin description

5.3.1 PONKEYn/EN

The PONKEYn/EN pin is a multifunctional pin that can be configured (see PKEY_EN_CFG NVM pin) with two different functions: As PONKEYn, it is intended to be connected to a push-button at the application level. If the push-button is pressed by a user, the PONKEYn signal is grounded. If the push-button is released by the user, the PONKEYn signal is floating, but the internal PMIC R_{PU} ties PONKEYn to V_{IN} . When configured as Enable, it turns the PMIC on or off, based on the programmed polarity.

Main characteristics as PONKEYn:

- Digital input
- Active low
- Programmable pull-up (RPU) internally connected to V_{IN} and pull-down (RPD)
- Debounce filter on rising and falling edges (see Figure 10)
- Turn-ON condition on falling edge (after debounce) when PMIC is in the OFF state.
- Turn-ON condition on low level from a PMIC POR (see Section 5.4.2)
- Interrupt on falling and rising edges (after debounce)
- Turn-OFF condition on PONKEYn long press (duration programmable)

Figure 10. PONKEYn debounce filter behavior

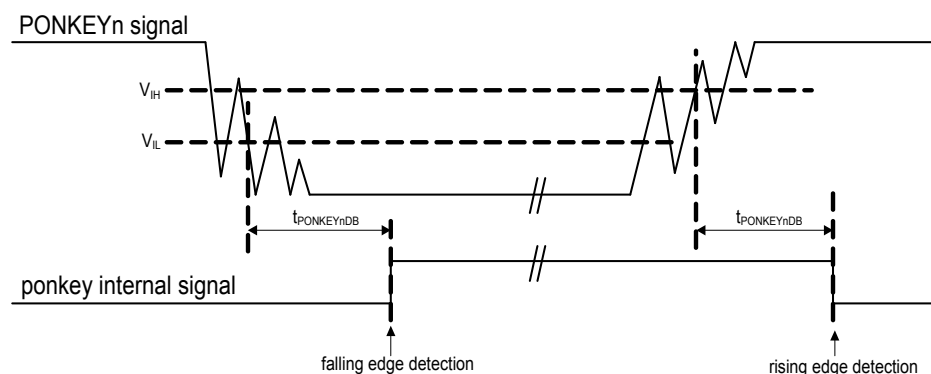

PONKEYn falling edge: the debounce filter timer is enabled once the PONKEYn voltage is lower than V_{IL} . If a bounce voltage higher than V_{IH} occurs, the debounce filter timer is canceled and so on.

PONKEYn rising edge: the debounce filter timer is enabled once the PONKEYn voltage is higher than V_{IH} . If a bounce voltage lower than V_{IL} occurs, the debounce filter timer is canceled and so on.

Main characteristics as EN:

- Digital input, level sensitive with V_{IL}/V_{IH} thresholds 1.8 V compatible
- Active high or low (programmable polarity)
- NVM or user level Programmable pull-up (RPU) internally connected to V_{IN} or pull-down (RPD)
- 30 μ s rising and falling deglitch
- Turn-ON and Turn-OFF conditions when (respectively) asserted or deasserted based on programmed polarity
- When configured, the following functionalities are disabled: PONKEYn turn-ON event (implicit) and long press Turn-OFF event and fail-safe skip, AUTO_TURN_ON, RREQ_EN.

RPU and RPD settings are independent from the PONKEYn/EN configuration.

5.3.2 RSTn

The RSTn is a bidirectional reset pin both for the PMIC and the application processor:

- Digital input: active low input reset (when not asserted by the PMIC). The application processor can assert RSTn low to force the PMIC to power cycle.
- Open drain output: The PMIC can assert RSTn low to reset the application processor, typically during a power-ON or a power-OFF sequence and a power cycling reset sequence. Pull-up (R_{PU}) is internally connected to V_{IO} .

5.3.3 INTn

The PMIC asserts INTn low when a PMIC interrupt is pending (and not masked):

- Digital output (open drain)
- Active low
- Pull-up (RPU) internally connected to V_{IO} .

5.3.4 PWRCTRL1, PWRCTRL2

Power control signals aim to control the regulator's behavior. Typically, power control signals are driven to '1' or '0' by the application processor to manage different power modes at application level.

PWRCTRLx pin characteristics:

- Digital input
- Level-sensitive
- Programmable polarity
- Rising and falling delay cells
- Inactive by default
- Programmable pull-up (RPU) internally connected to V_{IO} or pull-down (RPD), and RPU is active by default.
- No debounce

See Section 5.4.10 for behavior description.

5.3.5 GPO1, GPO2

General Purpose Output driven by PMIC via $GPOx_MAIN_CR$, $GPOx_ALT_CR$ like other regulators and PWRCTRL registers. A GPO can also be driven at power-up/power-down sequence (programmable in NVM like any regulator).

$GPOx$ are mainly targeted to control external discrete regulators or an additional PMIC (driven by EN pin). GPO can also be used to control any external peripherals on an application.

GPOx pin characteristics:

- Digital output (push-pull on V_{IN})
- Programmable polarity (an external discrete regulator usually has active high Enable pin input but sometime the Enable pin is active low)

Note: • *GPO are in high impedance when $0 < V_{IN} < V_{inpor}$.*

5.4 Feature descriptions

5.4.1 V_{IN} monitoring

The main input supply pin V_{IN} is monitored permanently by the PMIC state machine. There are different threshold triggers on V_{IN} . The lowest to the highest thresholds are: V_{INPOR} , V_{INOK} , and V_{INLOW} as shown in Figure 11.

Figure 11. V_{IN} monitoring thresholds

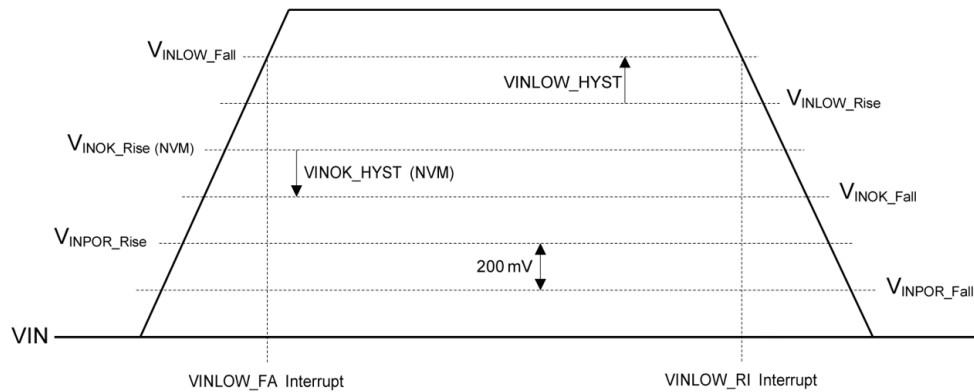

5.4.2 V_{INPOR}

V_{INPOR} is the minimum voltage required to supply the PMIC internal circuitry. It is specified by two hardcoded thresholds with 200 mV hysteresis:

Below V_{INPOR_Fall} , the PMIC is considered as not supplied.

Above V_{INPOR_Rise} , the PMIC internal circuitry is functional.

Note: Once V_{IN} rises above V_{INPOR_Rise} , PMIC internal circuitry remains functional until V_{IN} falls below V_{INPOR_Fall} . Refer to Section 3.4.1 for threshold values.

5.4.3 V_{INOK}

V_{INOK} is the minimal voltage required to allow the PMIC to work in the POWER_ON state.

It is specified by V_{INOK_Rise} threshold and V_{INOK_HYST} hysteresis values that can be adjusted in the NVM, respectively in the V_{INOK_RISE} [1:0] and V_{INOK_HYST} [1:0] bit fields.

If V_{IN} falls below V_{INOK_Fall} ($V_{INOK_Fall} = V_{INOK_Rise} - V_{INOK_HYST}$), then it is considered as a hard-fault turn-off condition and the PMIC immediately starts the POWER_DOWN sequence (see Section 5.2.5). Following this condition, the PMIC waits for the t_{VINOK_Fall} delay before it can restart, even if V_{IN} exceeds V_{INOK_Rise} again before the t_{VINOK_Fall} delay ends.

Definition: The $V_{IN} > V_{INOK}$ condition means that if V_{IN} rises above V_{INOK_Rise} , then V_{IN} remains higher than V_{INOK_Fall} . Reciprocally, $V_{IN} < V_{INOK}$ means that $V_{IN} < V_{INOK_Fall}$ or V_{IN} is less than the V_{INOK_Rise} threshold (this definition is just to simplify the state machine description).

5.4.4 V_{INLOW}

V_{INLOW} operates as a flag to trigger an interrupt: V_{INLOW_Fall} and V_{INLOW_Rise} are configurable software thresholds that notify the AP (via an interrupt line) when the V_{IN} voltage crosses one of those two thresholds.

V_{INLOW} can be enabled and configured by programming the register V_{INLOW_CR} .

V_{INLOW_Rise} and V_{INLOW_Fall} thresholds generate, respectively, V_{INLOW_RI} and V_{INLOW_FA} interrupts, allowing the application processor to take relevant action. They can be unmasked independently.

The V_{INLOW_RI} interrupt is asserted once V_{IN} goes below the V_{INLOW_Rise} threshold.

The V_{INLOW_FA} interrupt is asserted once V_{IN} goes above the V_{INLOW_Fall} threshold.

5.4.5 Turn-on conditions

A turn-on condition is required to power up the PMIC and to reach the $POWER_ON$ state. A turn-on condition is only valid from the OFF state, or alternatively from the NO_SUPPLY state (the PMIC has no V_{IN} initially).

The PMIC manages several turn-on conditions:

- $PONKEYn$ pin assertion or EN pin assertion
- $AUTO$ turn-on ($AUTO_TURN_ON$ bit set in the NVM, only if pin EN is not configured)
- Fail-safe restart condition

Note: A fail-safe restart condition is not a real turn-on condition, but rather an allowed restart condition following a failure event triggering a turn-off event. See [Section 5.4.6](#).

5.4.5.1 $PONKEYn$ / En turn-on detection conditions

A turn-on condition can be triggered by an external signal source from $PONKEYn/EN$ pin:

1. If $PONKEYn$ is set in the $PKEY_EN_CFG$ bit (NVM):
 - a. $PONKEYn$ is tied low initially. The PMIC is in a NO_SUPPLY state. When the V_{IN} voltage rises and crosses the V_{INPOR_Rise} threshold, the PMIC goes into the $INIT\&LOAD$ state (transition A), and then it goes into the $CHECK\&LOAD$ state (transition C).
 - b. $PONKEYn$ is initially released. The PMIC is in the OFF state. When the $PONKEYn$ is asserted, a turn-on condition occurs.
2. If EN is set in the $PKEY_EN_CFG$ bit (NVM):
 - EN asserted: always a turn-on condition (except if PMIC is in $FAIL_SAFE_LOCK$ state).

Table 18. Turn-on conditions from external trigger source summary

Source	Turn-on condition	Debounce
$PONKEYn$	$PONKEYn$ signal low from the PMIC in a NO_SUPPLY state when V_{IN} rises and crosses V_{INPOR_Rise}	30 μs
$PONKEYn$	$PONKEYn$ signal falling edge when the PMIC is in the OFF state	$t_{PONKEYnDB}$
EN	EN asserted (signal high or low depending of EN polarity set in NVM)	30 μs

5.4.5.2 $AUTO$ turn-ON

$AUTO$ turn-ON allows the PMIC to be turned ON automatically when V_{IN} rises from $V_{IN} < V_{INPOR_Fall}$. An $AUTO$ turn-ON event is triggered only from a NO_SUPPLY state transition:

1. V_{IN} rises from V_{INPOR_Fall} to V_{INPOR_Rise}
2. PMIC goes into $INIT\&LOAD$ state, then the $AUTO_TURN_ON$ bit is enabled in the NVM
3. PMIC goes into the $CHECK\&LOAD$ state, waiting for $V_{IN} > V_{INOK}$
4. PMIC $POWER_UP$

The $AUTO$ turn-ON is enabled in the NVM by default.

5.4.6 Turn-off conditions

Turn-off conditions are triggered by events or stimulus leading the PMIC to perform a POWER_DOWN sequence. Following the POWER_DOWN sequence, the PMIC can switch to the OFF state or to the FAIL_SAFE_LOCK state, or restart automatically (power cycle), depending on the source that has triggered the turn-off condition. There are six sources triggering a turn-off condition detailed in Table 19:

Table 19. Turn-off condition trigger sources

Source	Type	Turn-off condition	Power cycle condition
EN ⁽²⁾	Switch-off	EN deasserted (signal low or high depending of EN polarity set in EN_POL_CFG bit in NVM)	EN = asserted ⁽²⁾ (short deassertion pulse)
Software switch-off	Switch-off	Writing 1 to SWOFF bit	RREQ_EN = 1 EN = asserted ⁽²⁾
V _{INOK_Fall}	Hard-fault	V _{IN} falls below V _{INOK_Fall} threshold (with V _{IN} staying higher than V _{IN_POR_Fall}). See Section 5.4.1	VIN_FLT_CNT <= VIN_FLT_CNT_MAX && EN = asserted ⁽²⁾
PONKEY _n long key press	Hard-fault	PKEY_LKP_OFF bit set or NVM_PKEY_LKP_OFF bit set (NVM). Long key press duration can be set in PKEY_LKP_TMR [3:0] bit field or in NVM_PKEY_LKP_TMR [1:0] bit field (NVM) PONKEY _n signal is asserted low for a duration > PKEY_LKP_TMR [3:0]	PKEY_FLT_CNT <= PKEY_FLT_CNT_MAX
Thermal shutdown	Hard-fault	PMIC junction temperature exceeds T _{SHDN_Rise} threshold. See Section 5.4.5.2	TSHDN_FLT_CNT <= TSHDN_FLT_CNT_MAX && EN = asserted ⁽²⁾
Overcurrent protection	Hard-fault	Overcurrent detected on a regulator (related regulator NVM_FS_OCP_xxx ⁽¹⁾ bit set in NVM or FS_OCP_xxx ⁽¹⁾ bit set by software).	OCP_FLT_CNT <= OCP_FLT_CNT_MAX && EN = asserted ⁽²⁾
Watchdog	Hard-fault	Watchdog feature active and timer expired. See Section 5.4.6.1	WDG_FLT_CNT <= WDG_FLT_CNT_MAX && EN = asserted ⁽²⁾

1. xxx: instance name of the regulator, eg: LDO2, BUCK1

2. EN set in PKEY_EN_CFG bit in NVM

5.4.6.1 Turn-OFF condition triggered by software switch-off

When the software sets the SWOFF bit, the PMIC starts a POWER_DOWN sequence immediately, then the PMIC goes into the OFF state. The TURN_OFF_SR is set accordingly.

PONKEY_n set in PKEY_EN_CFG bit in NVM: If the software has set both the RREQ_EN and SWOFF bits, the PMIC restarts automatically after the POWER_DOWN sequence (transition K) and goes into the POWER_ON state. The RESTART_SR register is set accordingly.

EN set in PKEY_EN_CFG bit in NVM: If the software has set SWOFF bit while EN is asserted, the PMIC restarts automatically after the POWER_DOWN sequence (transition K) and goes into POWER_ON state.

The RESTART_SR register is set accordingly.

5.4.6.2 Turn-OFF condition triggered by a hard fault

Each hard-fault source has a hard-fault counter: see Table 20.

Each time a hard-fault event occurs, a turn-off condition is triggered, and it is managed by fail-safe management. See Section 5.4.7.

5.4.7 Fail-safe management

Each hard-fault source has an independent fail-safe counter that is incremented each time a hard-fault turn-off condition occurs (see Table 20). If the counter value is below (or equal to) the max limit, then the PMIC restarts (= power cycling on fault condition). Alternatively, if the counter is higher than the max limit, then the PMIC goes into the FAIL_SAFE_LOCK state to avoid cyclic hard failures.

Sequence details:

When a turn-off condition is triggered by a hard-fault source (see Table 19):

- The corresponding hard-fault counter is incremented (see Table 20): xxx_FLT_CNT ++
- The FLT_TMR is loaded with the corresponding hard-fault duration and starts (see Table 20)
- The PMIC switches to the POWER_DOWN sequence
- Once the POWER_DOWN sequence ends:
 - If all counters xxx_FLT_CNT <= xxx_FLT_CNT_MAX then the PMIC goes into the CHECK&LOAD state, then PMIC waits for a FLT_TMR timer expiration before restarting (see Table 20). Then it goes into POWER_UP, and then it goes in POWER_ON state. The corresponding bit in the RESTART_SR status register is set.
 - Else if one of the counters xxx_FLT_CNT > xxx_FLT_CNT_MAX, then PMIC goes into the FAIL_SAFE_LOCK state. The corresponding bit in the TURN_OFF_SR status register is set. Even when the FAIL_SAFE_LOCK is skipped, the PMIC waits for FLT_TMR expiration before restarting.

Note: If EN set in PKEY_EN_CFG bit in NVM, it is assumed that EN is kept asserted during the above sequence.

Table 20. Hard-fault fail-safe counters and waits before restarting timer

Source	Fail-safe counters	Max fault iteration (NVM shadow register)	Wait before restart timer duration FLT_TMR[x]
VINOK_Fall	VIN_FLT_CNT [3:0]	VIN_FLT_CNT_MAX [3:0]	tVINOK_Fall
PONKEYn long press	PKEY_FLT_CNT [3:0]	PKEY_FLT_CNT_MAX [3:0]	0
Thermal shutdown	TSHDN_FLT_CNT [3:0]	TSHDN_FLT_CNT_MAX [3:0]	tTSHDN_DLY
Overcurrent protection (OCP)	OCP_FLT_CNT [3:0]	OCP_FLT_CNT_MAX [3:0]	tHICCUP_DLY
Watchdog	WDG_FLT_CNT [3:0]	WDG_FLT_CNT_MAX [3:0]	0

Notes:

- 1 - When a counter (xxx_FLT_CNT [3:0]) reaches 0xF, all the next counter increments keep the counter value at 0xF (and not restart to 0). This allows for infinite PMIC restart iterations to be set when xxx_FLT_CNT_MAX [3:0] is set to 0xF.
- 2 - Setting 0 in xxx_FLT_CNT_MAX makes the PMIC go into the FAIL_SAFE_LOCK state after the first corresponding turn-off hard-fault condition (PMIC restarts 0 times).
- 3 - Setting 0xF in xxx_FLT_CNT_MAX makes the PMIC always restart after any corresponding urn-off fault condition as highlighted above in Note 1 (PMIC restarts indefinitely).
- 4 - Programming the NVM with tHICCUP_DLY = '0' means no wait before restart.

5.4.8 Hard-fault counters reset and auto-reset

To avoid reaching the FAIL_SAFE_LOCK state due to isolated turn-off hard-fault conditions, all counters can be reset automatically when no turn-off hard-fault condition occurs in RST_FTL_CNT_TMR timer duration (see Table 21 for timer duration NVM settings).

From the NO_SUPPLY state and until a first turn-off condition occurs, the RST_FTL_CNT_TMR timer is disabled.

Each time a turn-off hard-fault condition occurs, the RST_FTL_CNT_TMR timer is reset to the RST_FTL_CNT_TMR[1:0] value and restarted.

When the RST_FTL_CNT_TMR timer elapses:

- All counters (*_FLT_CNT) are reset
- The RST_FTL_CNT_TMR timer is stopped until a new turn-off hard-fault condition occurs

If PMIC reaches the FAIL_SAFE_LOCK state before the RST_FTL_CNT_TMR timer elapses, then RST_FTL_CNT_TMR timer is reset and stopped.

A RSTn condition has no effect on the RST_FTL_CNT_TMR timer.

In the OFF state, the RST_FTL_CNT_TMR timer is reset and stopped, and all counters (*_FLT_CNT) are reset.

Table 21. Reset fault counter timer settings

RST_FTL_CNT_TMR [1:0] (NVM shadow register)	Timer duration
00	disabled
01	1 min
10	6 min
11	60 min

5.4.9 FAIL_SAFE_LOCK state skipping

When the PMIC enters FAIL_SAFE_LOCK state, it remains in this state until PMIC POR ($V_{IN} < V_{INPOR_Fail}$).

Alternatively, there are three programmable options to force the PMIC to switch from the FAIL_SAFE_LOCK state to the OFF state:

- Set the bit FAIL_SAFE_LOCK_DIS in the NVM. It disables the FAIL_SAFE_LOCK feature (when the PMIC enters the FAIL_SAFE_LOCK state, it immediately transitions to the OFF state).
- A PKEY_EN_FAIL_SAFE_LOCK_SKIP condition
 - A PKEY_EN_FAIL_SAFE_LOCK_SKIP condition can be reached only if the PKEY_LKP_EN_FSLS (1) bit is set prior to entering the FAIL_SAFE_LOCK state (or if the NVM_PKEY_LKP_EN_FSLS bit is set in NVM, which automatically sets the PKEY_LKP_EN_FSLS bit) and:
 - A PONKEYn long key press event (if PONKEYn is set in the PKEY_EN_CFG bit (NVM))
 - An EN pin deassertion (if EN is set in the PKEY_EN_CFG bit (NVM))
- PKEY_LKP_EN_FSLS: PONKEY Long Key Press Fail-Safe-Lock-Skip bit / EN deasserted Fail-Safe-Lock-Skip bit)

Note: When the PMIC performs the transition from the FAIL_SAFE_LOCK state to the OFF state, a turn-on condition should occur to power up the PMIC (the AUTO_TURN_ON bit has no effect on the FAIL_SAFE_LOCK state to the OFF state transition).

5.4.10 Power control management (PWRCTRLx)

PWRCTRL1 and PWRCTRL2 are digital inputs controlled from an application processor (see Section 5.3.4). They are dedicated to managing different application power modes or special regulator reset features.

PWRCTRL1 and PWRCTRL2 can be independently muxed onto each regulator instance (BUCKx, LDOx or GPOx).

For example, BUCK1 may be controlled by PWRCTRL2, and BUCK2, BUCK2, and LDO5 can be controlled by PWRCTRL1, and so on.

A regulator instance and external command (GPO) can be controlled by a single PWRCTRL signal. For each regulator instance, a PWRCTRL input can be used either to:

- Switch between the xxx_MAIN_CR register or the xxx_ALT_CR register of a regulator (where xxx is the regulator instance)
- The regulator behaves according to the selected xxx_MAIN_CR or xxx_ALT_CR register
- Reset a regulator instance to its default value (from the NVM)

PWRCTRL1 or PWRCTRL2 can be used to suspend the watchdog, typically when the AP is in low-power mode.

Figure 12 provides the logic circuitry principle showing:

- How a buck converter is controlled by a PWRCTRLx

Figure 12. PWRCTRLx logic circuitry principle

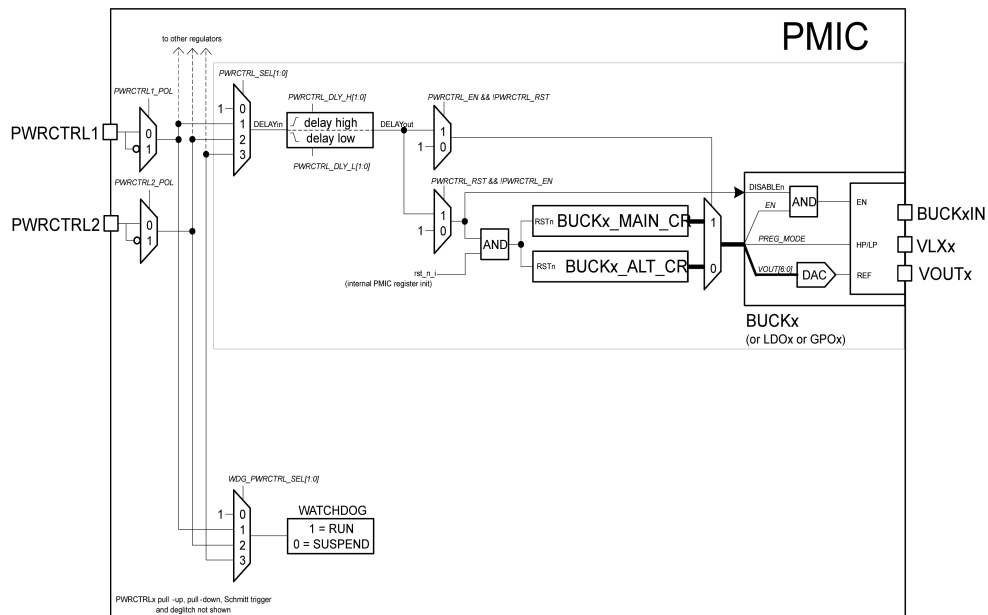

PWRCTRL1_POL and PWRCTRL2_POL bits set the polarity of PWRCTRL1 and PWRCTRL2 respectively. Those settings are applicable to all regulators and external commands (GPO) (not linked to a single regulator).

PWRCTRLx_POL: polarity of PWRCTRLx signal (with x = 1, 2): 0: active low; 1: active high. See Table 22.

Table 22. PWRCTRLx polarity truth table

PWRCTRLx input level	PWRCTRLx_POL	PWRCTRLx logic level
0	0	Active
1	0	Inactive
0	1	Inactive
1	1	Active

Note: x is the instance number of the PWRCTRL pin.

WDG_PWRCTRL_SEL [1:0]: Watchdog control source selection. When PWRCTRLx is active, the watchdog timer is suspended. When PWRCTRLx is inactive, the watchdog timer is running (if watchdog is enabled) (see Section 5.4.6.2).

Note: There is one instance of the following registers per regulator instance:

PWRCTRL_SEL [1:0]: BUCKx control/reset source selection.

PWRCTRL_DLY_H [1:0]: BUCKx control/reset source shift delay from low to high level (typically to perform the power ON sequence between different regulators; driven by a PWRCTRL signal). 0 = no delay; 1 = 1.5 ms delay; 2 = 3 ms delay; and 3 = 6 ms delay.

PWRCTRL_DLY_L [1:0]: BUCKx control/reset source shift delay from high to low level (typically to emulate the power OFF sequence between different regulators; driven by a PWRCTRL signal). 0 = no delay; 1 = 1.5 ms delay; 2 = 3 ms delay; and 3 = 6 ms delay.

PWRCTRL_EN: BUCKx control source enable. 0: disable, 1: enable. When enabled, BUCKx is controlled by a PWRCTRL signal:

- If PWRCTRL is inactive, the BUCKx_MAIN_CR register is used to control BUCKx
- If PWRCTRL is active, the BUCKx_ALT_CR register is used to control BUCKx

PWRCTRL_RST: BUCKx independent reset source enable. 0: disable, 1: enable. When enabled, BUCKx is reset by a PWRCTRL signal. See Section 5.4.12 for details:

1. If PWRCTRL is active
2. BUCKx is disabled (forced by the DISABLEn signal in Figure 15)
3. The BUCKx_MAIN_CR and BUCKx_ALT_CR registers are reset to default value (the NVM default value is reloaded in both registers).
4. If PWRCTRL is inactive, the BUCKx_MAIN_CR register is used to control BUCKx.

Notes:

- If both PWRCTRL_EN and PWRCTRL_RST are set by mistake, both the control source and independent reset features are disabled (no effect).
- The above bit field descriptions are also applicable for LDOs and GPOs replacing BUCKx with LDOx and GPOx respectively.

Table 23. Regulator control truth table

PWRCTRLx logic level	PWRCTRL_RST	PWRCTRL_EN	Regulator control register
Active or inactive	0	0	xxx_MAIN_CR
Active	0	1	xxx_ALT_CR
Inactive	0	1	xxx_MAIN_CR
Active	1	0	xxx regulator disabled (OFF) xxx_MAIN_CR & xxx_ALT_CR registers are reset to default value
Inactive	1	0	xxx_MAIN_CR
Active or inactive	1	1	xxx_MAIN_CR

Note: x is the instance number of the PWRCTRL pin; xxx is the instance name of a regulator.

5.4.11 PWRCTRL delay high and delay low behaviors

PWRCTRL delay blocks are independent for each regulator. A delay block allows a PWRCTRLx signal to shift by preprogrammed delays. Each delay block is composed of two parts (a delay high and a delay low). The first operates at a high input level, and the second operates at a low input level.

Delay blocks are typically used to emulate power sequences between regulators when entering or leaving a low-power mode.

High-level delay behavior:

When the input signal goes from low to high level, the high-level delay timer (PWRCTRL_DLY_H [1:0]) is started. Once the timer expires, the output goes high.

If the input signal changes from high to low before the high-level delay timer expires, the “high-level delay timer” is stopped and reset, and the output keeps the previous value.

Low-level delay behavior:

Same behavior as for the high-level delay but on low-level input.

When the input signal goes from high to low level, the low-level delay timer (PWRCTRL_DLY_L [1:0]) is started. Once the timer expires, the output goes low.

If the input signal changes from low to high before the low-level delay timer expires, the “low-level delay timer” is stopped and reset, and the output keeps the previous value.

Note: The high-level delay timer and low-level delay timer are both driven from a level (and not from an edge) to ensure that the output is always copying the input after any delay expires.

Figure 13 illustrates this example, using the PWRCTRL2 to control the BUCK1 and the BUCK2:

Settings for the Figure 13 example:

```
// BUCK1 settings
BUCK1_PWRCTRL_CR[PWRCTRL_SEL[1:0]] = 2; // PWRCTRL2 as BUCK1 control source
BUCK1_PWRCTRL_CR[PWRCTRL_DLY_H[1:0]] = 0; // no delay on PWRCTRL2 going from low to high forBUCK1
BUCK1_PWRCTRL_CR[PWRCTRL_DLY_L[1:0]] = 2; // 3 ms delay on PWRCTRL2 going from high to low forBUCK1
BUCK1_PWRCTRL_CR[PWRCTRL_EN] = 1; // enable the PWRCTRL input feature for BUCK1
// BUCK2 settings
BUCK2_PWRCTRL_CR[PWRCTRL_SEL[1:0]] = 2; // PWRCTRL2 as BUCK2 control source
BUCK2_PWRCTRL_CR[PWRCTRL_DLY_H[1:0]] = 2; // 3 ms delay on PWRCTRL2 going from low to high forBUCK2
BUCK2_PWRCTRL_CR[PWRCTRL_DLY_L[1:0]] = 0; // no delay on PWRCTRL2 going from high to low forBUCK2
BUCK2_PWRCTRL_CR[PWRCTRL_EN] = 1; // enable the PWRCTRL input feature for BUCK2.
```

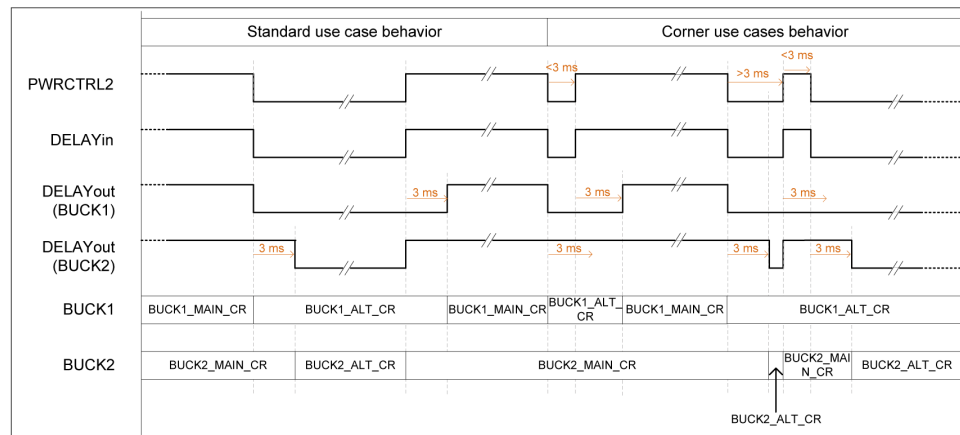
Figure 13. Delay rising and delay falling behaviors example.

5.4.12 Regulator-independent reset detailed behaviors (PWRCTRL_RST)

The independent reset feature is controlled by a PWRCTRLx input pin (PWRCTRL_SRC [1:0]) and it is enabled by setting the PWRCTRL_RST bit. This feature allows a regulator to reset to its default NVM value from an AP hardware signal “on the fly” (which cannot be done by I²C access).

When the PWRCTRLx input pin is active, regulator xxx is forced into OFF mode. xxx_MAIN_CR and xxx_ALT_CR registers are both reset to default values (the NVM default value is reloaded in both registers from the related NVM shadow register).

When the PWRCTRLx input pin is inactive, regulator xxx is controlled by xxx_MAIN_CR register content.

Figure 14 provides an example to illustrate regulator-independent reset behaviors using the PWRCTRL2 to control the LDO2 independent reset.

Assumptions and settings for the Figure 14 example:

LDO2 reset value (from the NVM):

- LDO2_MAIN_CR[VOUT] = 2.9 V
- LDO2_MAIN_CR[EN] = 1

Software settings:

PWRCTRL2_POL = 0; // PWRCTRL2 active low

// LDO2 settings

LDO2_PWRCTRL_CR[PWRCTRL_SEL [1:0]] = 3; // PWRCTRL2 as LDO2 control source

LDO2_PWRCTRL_CR[PWRCTRL_DLY_H [1:0]] = 0; // no delay on PWRCTRL2 going high for LDO2

LDO2_PWRCTRL_CR[PWRCTRL_DLY_L [1:0]] = 0; // no delay on PWRCTRL2 going low for LDO2

LDO2_PWRCTRL_CR[PWRCTRL_RST] = 1; // enable the PWRCTRL2 input to control LDO2 independent reset

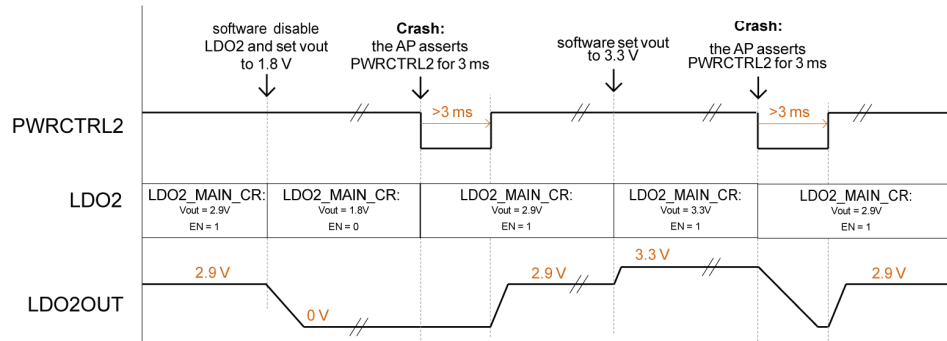
Figure 14. Regulator-independent reset behavior example

5.4.13 Reset management (RSTn) and mask_reset software option

RSTn is a bidirectional reset pin both for the PMIC and the application processor. It has a digital input/open drain output topology with an internal pull-up resistor (RPU).

- When the PMIC asserts RSTn, it drives the RSTn signal low (open drain internal transistor). The application processor is forced into a reset state.
- When the PMIC does not assert RSTn, the RSTn pin is in high impedance and the RSTn signal goes high (due to the pull-up resistor) if the RSTn signal is not asserted low externally (for example by a reset push-button or from an application processor asserting the reset signal low). In that case, the PMIC RSTn pin becomes a digital input and it monitors the RSTn signal.

In the POWER_ON state, the RSTn pin can be driven by the application processor or a reset push-button.

When the application processor asserts RSTn low exceeding the t_{RSTnAS} duration, it immediately triggers a reset sequence of the PMIC by performing a non-interruptible power cycle:

1. The PMIC asserts RSTn low (forcing the AP to keep it in reset, and in case that the AP releases the reset before the end of the sequence)
2. POWER_DOWN sequence
3. CHECK&LOAD
4. POWER_UP sequence
5. PMIC deasserts RSTn and monitors RSTn
6. PMIC waits for the RSTn signal to go high before entering POWER_ON (to prevent an infinite loop of reset sequences)

The PMIC can detect a negative pulse on RSTn shorter than the t_{RSTnAS} duration. The PMIC must detect a negative pulse longer or equal to the t_{RSTnAS} duration.

5.4.13.1 mask_reset software option

From step 2 to step 4 (in the above sequence), LDOs, GPOs and buck regulators follow a POWER_DOWN sequence followed by a POWER_UP sequence as defined in Section 5.2 except for regulators with the **mask_reset** option bit set.

The **mask_reset** option can be defined for each regulator by setting the corresponding MRST bit in the corresponding BUCKS_MRST_CR or LDOS_MRST_CR or GPOS_MRST_CR registers.

When the **mask_reset** option is set to a regulator, the MAIN and ALTERNATE related registers are not reset and content is maintained during and after the reset power cycle. Nevertheless, the PWRCTRLx settings are reset for all regulators, including those with the **mask_reset** option set:

- POWER_DOWN is not performed.
- MAIN and ALTERNATE register values are not reset, and their contents are maintained with the current value
- PWRCTRLx register settings are reset (xxx_PWRCTRL_CR)

The PMIC always ends the power cycle in the POWER_ON state, regardless of the PWRCTRLx value, as all PWRCTRLx settings have been reset during the power cycle.

If RSTn is asserted in MAIN mode, regulators with the **mask_reset** option set are not impacted at all by the reset sequence, keeping V_{OUT}, EN, and PREG_MODE unchanged.

If RSTn is asserted in the ALTERNATE mode, V_{OUT}, EN, and PREG_MODE switch to the content of the [regulator]_MAIN_CR register values when the POWER_DOWN sequence ends before the POWER_UP sequence starts.

Figure 15 illustrates a reset power cycle of the PMIC.

Figure 15. Reset power-cycle sequence example.

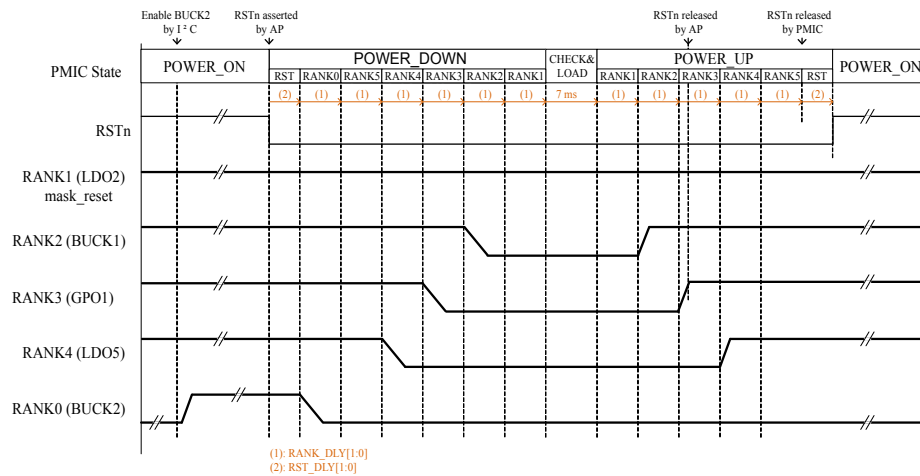

For RANK_DLY and RST_DLY, see Table 80.

Settings related to the example in Figure 15:

LDO5 with mask_reset option set (LDOS_MRST_CR[LDO2_MRST] = 1) is not impacted by the reset power-cycle.

BUCK1, BUCK2, and LDO4 are powered down and up at their respective ranks defined in the NVM. LDO5 is enabled by I²C. So, it is powered down first and not restarted (as not defined in the NVM to start). Mask_reset is valid once. It is cleared in the CHECK&LOAD state. So, it is cleared following a turn-off condition, a VINPOR, and a RSTn assertion.

When RSTn is released by the application processor, the PMIC keeps RSTn asserted (the RSTn signal stays low), meaning that the application processor is kept in reset until the PMIC releases the RSTn signal.

5.4.14 Thermal protection

The PMIC implements a thermal protection to prevent overheating damage. PMIC junction temperature is permanently monitored by an embedded thermal sensor.

The first level of thermal protection consists of an alarm sent by an interrupt to the application processor:

- When T_j rises above the TWRN_Rise threshold, the PMIC generates a THW_RI interrupt
- When T_j falls below the TWRN_Fall threshold, the PMIC generates a THW_FA interrupt

The application processor can decrease the application activity load, in order to decrease the application power consumption. Alternatively, a second level of thermal protection may occur.

The second level of thermal protection consists of triggering a turn-off hard-fault condition:

- When T_j rises above the TSHDN_Rise threshold, the PMIC generates a turn-off hard-fault condition, and the thermal fail-safe counter is incremented (TSHDN_FLT_CNT ++):
 - If the thermal fail-safe counter reaches the maximum number of power cycles defined in the NVM (TSHDN_FLT_CNT > TSHDN_FLT_CNT_MAX), then the PMIC goes into the FAIL_SAFE_LOCK state.
 - Alternatively, when T_j falls below the TSHDN_Fall threshold and a tTSHDN_DLY delay ends, the PMIC restarts.

See Section 5.4.7 for details about fail-safe counter management.

Figure 16. Thermal protection thresholds

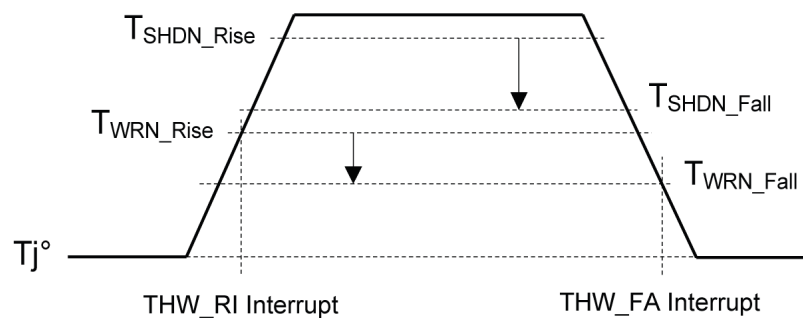

5.4.15 Overcurrent (OCP) and Hiccup mode

All regulators implement protection against overcurrent (OC) on their output.

Note: Short-circuits (SC) are managed by the overcurrent protection.

For each regulator, the PMIC embeds 2 levels of protection against overcurrent and short-circuits:

- Level 0 (default): independent regulator OCP Hiccup mode management
- Level 1: PMIC OCP fail-safe management (see Section 5.4.7)

The default level of protection is defined in the NVM (NVM_FS_OCP_SHR1/2) for each regulator, and can be changed at runtime by software (FS_OCP_CR1/2).

5.4.16 Level 0: Independent regulator OCP Hiccup mode management

Each PMIC regulator operates independently in Hiccup mode:

- When a short-circuit or an overcurrent occurs, the output current is limited to ILDO LIM (for LDO) and IBKLIM (for buck).
- If the SC or OC lasts more than t_{OCPDB_LDO} or t_{OCPDB_BUCK} (respectively for LDO or buck):
 - The regulator turns OFF for the t_{HICCUP_DLY} duration
 - An interrupt is generated (if the interrupt is unmasked by software)
- Once the t_{HICCUP_DLY} timer elapses, the regulator turns ON
 - If the SC or OC is removed, the LDO operates normally
 - If the SC or OC stays present, the regulator goes into step 1, repeating the cycle until the overload disappears (hiccup)

Notes:

- 1) When the $t_{\text{HICCUP_DLY}}$ timer duration is set to 0, the regulator is turned-OFF (interrupt-generated) and it does not restart (step 3 is skipped).
 - 2) The $t_{\text{HICCUP_DLY}}$ timer duration can be adjusted in the NVM by setting the HICCUP_DLY [1:0] bit field in the NVM_BUCKS_IOUT_SHR2 shadow register, then programming the NVM.
- 3) The $t_{\text{HICCUP_DLY}}$ timer is reset if a POWER_DOWN occurs at the same time. In this way, the IP can restart with its assigned RANK at the next POWER_UP. This happens even if the mask reset is set and/or $t_{\text{HICCUP_DLY}}$ is set to '0'.

5.4.17 Level 1: PMIC OCP fail-safe management

Each PMIC regulator can be set independently to trigger a hard-fault condition when an overcurrent or a short circuit occurs:

- When a short-circuit or an overcurrent occurs, the output current is limited to ILDOLIM (for LDO) and IBKLIM (for buck).
- If the SC or OC lasts more than $t_{\text{OCPDB_LDO}}$ or $t_{\text{OCPDB_BUCK}}$ (respectively for LDO or buck), the PMIC generates a turn-off hard-fault condition. OCP_SR1 or OCP_SR2 is updated with the OCP fault source, and the OCP fail-safe counter (1) is incremented (OCP_FLT_CNT ++):
 - If the OCP fail-safe counter reaches the maximum number of power cycles defined in the NVM ($\text{OCP_FLT_CNT} > \text{OCP_FLT_CNT_MAX}$), the PMIC goes into FAIL_SAFE_LOCK state.
 - Alternatively, when the $t_{\text{HICCUP_DLY}}$ delay ends, the PMIC restarts.

There is a single OCP fail-safe counter (OCP_FLT_CNT) for all regulators. It is incremented each time a regulator triggers a hard-fault regardless of the regulator instance.

5.4.18 Watchdog management

The PMIC has an internal watchdog timer. A watchdog timer expiration generates a turn-off hard-fault condition (see Section 5.4.6) followed either by a PMIC restart (power cycling) or by the PMIC going into the FAIL_SAFE_LOCK state.

The watchdog can be enabled/disabled by software or at power-up (NVM settings):

- Software: set/reset WDG_EN bit at runtime
- NVM: set/reset NVM_WDG_EN bit, then program the NVM

The watchdog timer duration can be set in a range from 1 s to 256 s in 1 s steps by setting the WDG_TMR_SET [7:0] bit field. The default watchdog timer duration can be set in the NVM by setting NVM_WDG_TMR_SET [1:0], then programming the NVM.

Note: Each time the NVM is reloaded (typically in the CHECK&LOAD state), the NVM_WDG_EN bit is copied into the WDG_EN bit and the NVM_WDG_TMR_SET [1:0] bit field related duration is set into the WDG_TMR_SET [7:0] bit field. In the POWER_ON state, the software can override the default watchdog values (NVM) by setting the WDG_EN bit and/or the WDG_TMR_SET [7:0] bit field.

As soon as the watchdog is enabled, the software should periodically set the WDG_RST bit (self-cleared) to reload the timer down counter WDG_TMR_CNT [7:0] with the value defined in the WDG_TMR_SET [7:0] bit field. The software can read the watchdog timer down counter (WDG_TMR_CNT [7:0]) to check the remaining duration before expiration.

A turn-OFF hard-fault condition occurs if the watchdog timer expires. The turn-off condition is followed by a POWER_DOWN sequence either by a PMIC restart (POWER_UP then POWER_ON) or by the PMIC going into the FAIL_SAFE_LOCK state. (See Section 5.4.7 for details about the behavior following a turn-off hard-fault event).

Enabling the watchdog (from WDG_EN = 0 to 1) to reload the timer down counter (WDG_TMR_CNT [7:0]) with the value defined in the WDG_TMR_SET [7:0] bit field.

When enabled, the watchdog timer remains active in the POWER_ON state.

The watchdog timer can be disabled at runtime by setting WDG_EN = 0. Alternatively, the watchdog timer is automatically disabled when PMIC goes into the OFF state or the FAIL_SAFE_LOCK state (regardless of turn-OFF condition source).

When enabled (WDG_EN = 1), the watchdog timer can be suspended automatically from one PWRCTRLx signal. The WDG_PWRCTRL_SEL [1:0] bit field allows for the selection of the PWRCTRLx source to suspend the watchdog. It is suitable to automatically suspend/freeze the watchdog when the application is in low-power mode:

- When PWRCTRLx is inactive (the application is running), the watchdog timer down counter is running. The software should set the WDG_RST bit periodically to reload the timer down counter.
- When PWRCTRLx is active (the application is in low-power mode), the watchdog timer down counter is suspended (frozen). When PWRCTRLx becomes inactive (the application leaves the low-power mode), the watchdog down counter restarts from the current WDG_TMR_CNT [7:0] value (counter WDG_TMR_CNT [7:0] is not reloaded from WDG_TMR_SET [7:0] value).

5.5 Programming

5.5.1 I²C interface

The I²C interface works in slave mode. It supports both standard and fast modes with a data rate up to 400 Kb/s. It also supports fast mode plus (FM+) with a data rate up to 1 Mb/s.

Fm and Fm+ standards are supported with total spike pulse time (t_{SP}) up to 25 ns max while the $V_{OL} = 0.4$ V is guaranteed with I_{OL} up to 4 mA (Refer to NXP UM10204).

The STPMIC1L I²C interface is intended to be addressed exclusively via a dedicated microprocessor I²C BUS.

5.5.1.1 Slave address

There is an I²C slave address for the STPMIC1L.

The address is stored in the NVM_I²C_ADDR_SHR[6:0] shadow register bit field. The hard-coded I²C default address defined in the NVM is 0x33.

Table 24. Slave address format

b7	b6	b5	b4	b3	b2	b1	b0
AddID6	AddID5	AddID4	AddID3	AddID2	AddID1	AddID0	R/W

5.5.1.2 Read/write operation.

Each transaction is composed of a start condition followed by an 8-bit packet number representing either a device ID plus R/W command, register address, or register data coming to/from the slave.

See Table 28. An acknowledgment is needed after each packet. This acknowledgment is given by the receiver of the packet. Transaction examples are given in Table 29 and Table 30. Multi-read and multi-write operations are supported.

Table 25. Register address format

b7	b6	b5	b4	b3	b2	b1	b0
RegAdd7	RegAdd6	RegAdd5	RegAdd4	RegAdd3	RegAdd2	RegAdd1	RegAdd0

Table 26. Register data format

b7	b6	b5	b4	b3	b2	b1	b0
DATA7	DATA6	DATA5	DATA4	DATA3	DATA2	DATA1	DATA0

Figure 17. I²C read operation

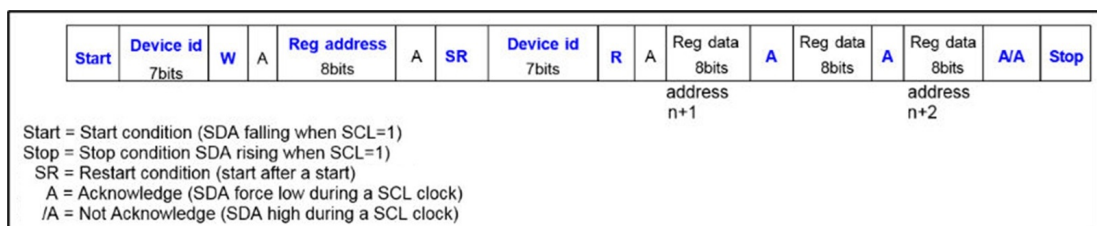
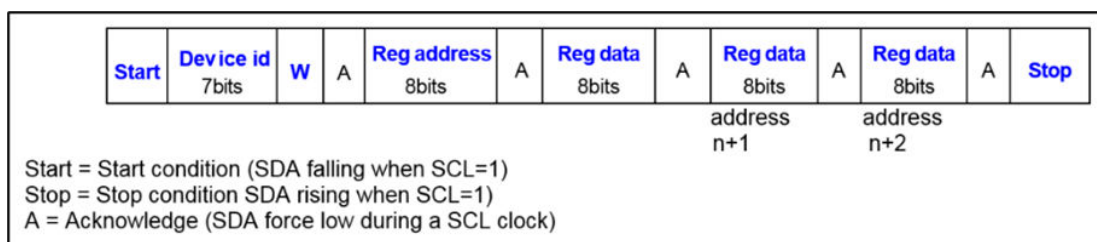

Figure 18. I²C write operation



5.5.2 Non-volatile memory (NVM)

The PMIC's built-in non-volatile memory provides high flexibility to support a wide range of applications.

Its write management through I²C allows for the customization of the PMIC directly in final applications during product development and mass production.

The NVM read operation is performed automatically in the INIT&LOAD state and in the CHECK&LOAD state to set control registers with default values and configure the POWER_UP and POWER_DOWN sequence.

The NVM write operation can be performed several times (NVMEND cycles max) during application development debugging procedures. Once the final settings have been defined, these can be written in the NVM content of each part mounted on the customer application that is written in the production line under a controlled environment.

In addition, the PMIC supports the NVM CRC check (or checksum) to guarantee its content integrity. The CRC is computed by the PMIC during an NVM write operation. After the NVM write, the user reads back the NVM content to check that the content is OK (and implicitly that the computed CRC is valid). Then, each time the PMIC reads the NVM (in the INIT&LOAD and in the CHECK&LOAD states) if the CRC is not OK, the PMIC does not start up.

5.5.2.1 **NVM read operation**

The NVM read operation is fully managed by the PMIC.

For each read operation, the PMIC automatically loads the NVM content into NVM shadow registers. It means that shadow register content is a copy of NVM content.

When the PMIC power supply is connected ($V_{IN} > V_{INPOR_Rise}$), the PMIC state machine goes into the INIT&LOAD state (see Section 5.1). In this state, an NVM read operation is performed to check if the PMIC can start up automatically, depending on the AUTO_TURN_ON NVM bit value.

If the AUTO_TURN_ON bit is not set, the PMIC goes into the OFF state, or into the CHECK&LOAD state and continues to POWER_UP automatically.

Before each POWER_UP sequence, the NVM read operation is performed in the CHECK&LOAD state. NVM content is loaded into shadow registers and NVM content integrity is checked with CRC. Additionally, the PMIC initializes BUCK and LDO control registers with values predefined in the NVM and it configures the POWER_UP and POWER_DOWN sequence of regulators.

5.5.2.2 **NVM write operation (PMIC customization)**

The NVM write operation can be performed by the I²C interface for customization purposes (see max cycles in NVMEND).

The writing procedure can be performed in two ways:

- Customizing a pre-programmed device directly from the application host processor via the I²C interface

NVM write operation generic sequence:

1. Apply V_{IN} to the application: the PMIC goes into the POWER_ON state (*)
2. Write NVM shadow registers with expected customization values
3. Initiate a “NVM program operation” command: write NVM_CMD [1:0] = ‘01’
4. Wait for the NVM write operation to be completed: wait for NVM_BUSY to become 0
5. Check for the NVM write operation to succeed: NVM_WRITE_FAIL = 0 in NVM_SR
6. Check new NVM content by initiating an NVM read operation: write NVM_CMD [1:0] = ‘10’ and wait for NVM_BUSY to become 0
7. A power OFF/ON cycle is needed to load the new NVM content.

The following conditions should be fulfilled to allow an NVM write operation:

- V_{IN} must be minimum VNVM_PROG

The NVM write operation works at least in the POWER_ON state to allow the application to reprogram the NVM at runtime (via I²C). Writing into NVM shadow registers does not affect NVM content until the NVM write operation is executed.

WARNING: If V_{IN} goes below VNVM_PROG during the write operation, the NVM content integrity may be corrupted and the PMIC may not start up anymore.

*. The PMIC has the AUTO_TURN_ON bit set by default to power up automatically. This is to enable NVM write operation without generating turn-on conditions.

5.5.2.3 **I²C address:**

Special attention must be given when a new I²C address needs to be programmed.

When a different I²C address is written in NVM_I²C_ADDR_SHR, this new address becomes effective only after a “NVM write operation” after reloading the NVM (INIT&LOAD or CHECK&LOAD state).

If a “NVM write operation” is not performed following the I²C address change in the shadow register, the previously programmed I²C address is loaded from the NVM during the next POWER_UP sequence.

5.5.2.4 **LOCK_NVM write operation**

When the PMIC is customized with the LOCK_NVM bit set in the NVM_I²C_ADD_SHR followed by a programming command (NVM_CMD [1:0] = 0b01), then the NVM write operation becomes disabled immediately. Any new programming command execution is ignored and the NVM_WRITE_FAIL bit is set in NVM_SR.

6 Register descriptions

6.1 Register map

All NVM_xxx bits of shadow registers have related xxx mirror bits in the control registers section allowing the software to override the NVM's predefined values at runtime. Each time the NVM is reloaded, related xxx mirror bits are also reloaded with the NVM's predefined values.

All bits specified as reserved in registers with R/W must not be modified.

So, before writing on a register with a reserved bit, the user should read the content of the register and should only modify bits that are not reserved, then write to the register.

hex	Register Name	R/W	BITS[7:0]							
			7	6	5	4	3	2	1	0
Status registers										
0x00	Product_ID	R	PMIC_REF_ID[3:0]				PMIC_NVM_ID[3:0]			
0x01	Version_SR	R	MAJOR_VERSION[3:0]				MINOR_VERSION[3:0]			
0x02	TURN_ON_SR	R	-	-	-	-	AUTO	-	-	PKEY_EN
0x03	TURN_OFF_SR	R	EN	-	WDG_FLT	THSDN_FLT	OCP_FLT	VIN_FLT	PKEY_FLT	SWOFF
0x04	RESTART_SR	R	R_EN	R_RST	R_WDG_FLT	R_THSDN_FLT	R_OCP_FLT	R_VIN_FLT	R_PKEY_FLT	R_SWOFF
0x05	OCP_SR1	R	-	-	-	-	-	-	OCP_BUCK2	OCP_BUCK1
0x06	OCP_SR2	R	-	-	-	OCP_LDO5	OCP_LDO4	OCP_LDO3	OCP_LDO2	-
0x07	EN_SR1	R	-	-	-	-	-	-	EN_BUCK2	EN_BUCK1
0x08	EN_SR2	R	-	-	-	EN_LDO5	EN_LDO4	EN_LDO3	EN_LDO2	-
0x09	FS_CNT_SR1	R	VIN_FLT_CNT[3:0]				PKEY_FLT_CNT[3:0]			
0x0A	FS_CNT_SR2	R	THSDN_FLT_CNT[3:0]				OCP_FLT_CNT[3:0]			
0x0B	FS_CNT_SR3	R	-	-	-	-	WDG_FLT_CNT[3:0]			
0x0C	MODE_SR	R	OP_MODE[3:0]				-	-	PWRCTRL 2	PWRCTRL 1
0x0D	GPO_SR	R	-	-	-	-	-	-	GPO2_EN	GPO1_EN
Control registers										
0x10	MAIN_CR	R/W	-	-	-	-	PWRCTRL_POL[1:0]		RREQ_EN	SWOFF
0x11	VINLOW_CR	R/W	-	-	VINLOW_HYST[1:0]		VINLOW_RISE[2:0]		VINLOW_EN	
0x12	PKEY_LKP_CR	R/W	PKEY_LKP_OF	PKEY_LKP_EN_FLS	-	-	PKEY_LKP_TMR[3:0]			
0x13	WDG_CR	R/W	-	-	-	-	WDG_PWRCTRL[1:0]		WDG_RST	WDG_EN
0x14	WDG_TMR_CR	R/W	WDG_TMR_SET[7:0]							

hex	Register Name	R/W	BITS[7:0]							
			7	6	5	4	3	2	1	0
Status registers										
0x15	WDG_TMR_SR	R	WDG_TMR_CNT[7:0]							
0x16	FS_OCP_CR1	R/W	-	-	-	-	-	-	FS_OCP_BUCK2	FS_OCP_BUCK1
0x17	FS_OCP_CR2	R/W	-	-	-	FS_OCP_LDO5	FS_OCP_LD04	FS_OCP_LD03	FS_OCP_LD02	-
0x18	PADS_PULL_CR	R/W	-	-	PWRCTRL2_PULL[1:0]		PWRCTRL1_PULL[1:0]		PKEY_EN_PULL[1:0]	
0x19	BUCKS_PD_CR	R/W	-	-	-	-	BUCK2_PD[1:0]		BUCK1_PD[1:0]	
0x1B	LDOS_PD_CR	R/W	-	-	-	LDO5_PD	LDO4_PD	LDO3_PD	LDO2_PD	-
0x1C	GPO_MRS_T_CR	R/W	-	-	-	-	-	GPO2_MRS_T	GPO1_MRST	-
0x1D	BUCKS_MRST_CR	R/W	-	-	-	-	-	-	BUCK2_MRS_T	BUCK1_MRST
0x1E	LDOS_MRST_CR	R/W	-	-	-	LDO5_MRST	LDO4_MRS_T	LDO3_MRS_T	LDO2_MRST	-
BUCK control registers										
0x20	BUCK1_MAIN_CR1	R/W	-	VOUT[6:0]						
0x21	BUCK1_MAIN_CR2	R/W	-	-	-	-	-	PREG_MODE[1:0]		EN
0x22	BUCK1_AL_T_CR1	R/W	-	VOUT[6:0]						
0x23	BUCK1_AL_T_CR2	R/W	-	-	-	-	-	PREG_MODE[1:0]		EN
0x24	BUCK1_PWRCTRL_CR	R/W	PWRCTRL_DLY_H[1:0]		PWRCTRL_DLY_L[1:0]		PWRCTRL_SEL[1:0]		PWRCTRL_RST	PWRCTRL_EN
0x25	BUCK2_MAIN_CR1	R/W	-	VOUT[6:0]						
0x26	BUCK2_MAIN_CR2	R/W	-	-	-	-	-	PREG_MODE[1:0]		EN
0x27	BUCK2_AL_T_CR1	R/W	-	VOUT[6:0]						
0x28	BUCK2_AL_T_CR2	R/W	-	-	-	-	-	PREG_MODE[1:0]		EN
0x29	BUCK2_PWRCTRL_CR	R/W	PWRCTRL_DLY_H[1:0]		PWRCTRL_DLY_L[1:0]		PWRCTRL_SEL[1:0]		PWRCTRL_RST	PWRCTRL_EN
0x43	GPO1_MAIN_CR	R/W	-	-	-	-	-	-	-	EN
0x44	GPO1_ALT_CR	R/W	-	-	-	-	-	-	-	EN
0x45	GPO1_PWRCTRL_CR	R/W	PWRCTRL_DLY_H[1:0]		PWRCTRL_DLY_L[1:0]		PWRCTRL_SEL[1:0]		PWRCTRL_RST	PWRCTRL_EN

hex	Register Name	R/W	BITS[7:0]							
			7	6	5	4	3	2	1	0
Status registers										
0x46	GPO2_MAIN_CR	R/W	-	-	-	-	-	-	-	EN
0x47	GPO2_ALT_CR	R/W	-	-	-	-	-	-	-	EN
0x48	GPO2_PWRCTRL_CR	R/W	PWRCTRL_DLY_H[1:0]		PWRCTRL_DLY_L[1:0]		PWRCTRL_SEL[1:0]		PWRCTRL_RST	PWRCTRL_EN
LDO control registers										
0x4F	LDO2_MAIN_CR	R/W	-	-	VOUT[4:0]				EN	
0x50	LDO2_ALT_CR	R/W	-	-	VOUT[4:0]				EN	
0x51	LDO2_PWRCTRL_CR	R/W	PWRCTRL_DLY_H[1:0]		PWRCTRL_DLY_L[1:0]		PWRCTRL_SEL[1:0]		PWRCTRL_RST	PWRCTRL_EN
0x52	LDO3_MAIN_CR	R/W	SNK_SRC	-	VOUT[4:0]				EN	
0x53	LDO3_ALT_CR	R/W	SNK_SRC	-	VOUT[4:0]				EN	
0x54	LDO3_PWRCTRL_CR	R/W	PWRCTRL_DLY_H[1:0]		PWRCTRL_DLY_L[1:0]		PWRCTRL_SEL[1:0]		PWRCTRL_RST	PWRCTRL_EN
0x55	LDO4_MAIN_CR	R/W	-	-	-	-	-	-	EN	
0x56	LDO4_ALT_CR	R/W	-	-	-	-	-	-	EN	
0x57	LDO4_PWRCTRL_CR	R/W	PWRCTRL_DLY_H[1:0]		PWRCTRL_DLY_L[1:0]		PWRCTRL_SEL[1:0]		PWRCTRL_RST	PWRCTRL_EN
0x58	LDO5_MAIN_CR	R/W	-	-	VOUT[4:0]				EN	
0x59	LDO5_ALT_CR	R/W	-	-	VOUT[4:0]				EN	
0x5A	LDO5_PWRCTRL_CR	R/W	PWRCTRL_DLY_H[1:0]		PWRCTRL_DLY_L[1:0]		PWRCTRL_SEL[1:0]		PWRCTRL_RST	PWRCTRL_EN
Interrupt control registers										
0x70	INT_PENDING_R1	R	-	-	VINLOW_RI	VINLOW_FA	-	-	PKEY_RI	PKEY_FA
0x71	INT_PENDING_R2	R	-	-	-	-	-	-	THW_RI	THW_FA
0x72	INT_PENDING_R3	R	-	-	-	-	-	-	BUCK2_OCP	BUCK1_OCP
0x73	INT_PENDING_R4	R	-	-	-	LDO5_OCP	LDO4_OCP	LDO3_OCP	LDO2_OCP	
0x74	INT_CLEAR_R1	W/R/SC	-	-	VINLOW_RI_CLR	VINLOW_FA_CLR	-	-	PKEY_RI_CLR	PKEY_FA_CLR

hex	Register Name	R/W	BITS[7:0]								
			7	6	5	4	3	2	1	0	
Status registers											
0x75	INT_CLEAR_R2	W/R0/SC	-	-	-	-	-	-	-	THW_RI_CLR	THW_FA_CLR
0x76	INT_CLEAR_R3	W/R0/SC	-	-	-	-	-	-	-	BUCK2_OCP_CLR	BUCK1_OCP_CLR
0x77	INT_CLEAR_R4	W/R0	-	-	-	LDO5_OCP_CLR	LDO4_OCP_CLR	LDO3_OCP_CLR	LDO2_OCP_CLR	-	-
0x78	INT_MASK_R1	R/W	-	-	VINLOW_RI_MASK	VINLOW_FA_MASK	-	-	-	PKEY_RI_MASK	PKEY_FA_MASK
0x79	INT_MASK_R2	R/W	-	-	-	-	-	-	-	THW_RI_MASK	THW_FA_MASK
0x7A	INT_MASK_R3	R/W	-	-	-	-	-	-	-	BUCK2_OCP_MASK	BUCK1_OCP_MASK
0x7B	INT_MASK_R4	R/W	-	-	-	LDO5_OCP_MASK	LDO4_OCP_MASK	LDO3_OCP_MASK	LDO2_OCP_MASK	-	-
0x7C	INT_SRC_R1	R	-	-	VINLOW	!VINLOW	-	-	-	PKEY	!PKEY
0x7D	INT_SRC_R2	R	-	-	-	-	-	-	-	THW	!THW
0x7E	INT_SRC_R3	R	-	-	-	-	-	-	-	BUCK2_OCP_STATUS	BUCK1_OCP_STATUS
0x7F	INT_SRC_R4	R	-	-	-	LDO5_OCP_STATUS	LDO4_OCP_STATUS	LDO3_OCP_STATUS	LDO2_OCP_STATUS	-	-
0x80	INT_DBG_LATCH_R1	W/R0/SC	-	-	VINLOW_RI_FRC	VINLOW_FA_FRC	-	-	-	PKEY_RI_FRC	PKEY_FA_FRC
0x81	INT_DBG_LATCH_R2	W/R0/SC	-	-	-	-	-	-	-	THW_RI_FRC	THW_FA_FRC
0x82	INT_DBG_LATCH_R3	W/R0/SC	-	-	-	-	-	-	-	BUCK2_OCP_FRC	BUCK1_OCP_FRC
0x83	INT_DBG_LATCH_R4	W/R0/SC	-	-	-	LDO5_OCP_FRC	LDO4_OCP_FRC	LDO3_OCP_FRC	LDO2_OCP_FRC	-	-
NVM user control registers											
0x8E	NVM_SR	R	-	-	-	-	-	-	-	WRITE_FAIL	BUSY
0x8F	NVM_CR	R/W	-	-	-	-	-	-	-	CMD[1:0]	
NVM user shadow registers											
0x90	MAIN_CTRL_SHR1	R/W	VINOK_HYST[1:0]		VINOK_RISE[1:0]		NVM_WDG_TMR_SET[1:0]		NVM_WDG_EN	AUTO_TURNON	
0x91	MAIN_CTRL_SHR2	R/W	RANK_DLY[1:0]		RST_DLY[1:0]		NVM_PKEY_LKP_OFF	NVM_PKEY_LKP_EN_FLS	NVM_PKEY_LKP_TMR[1:0]		
0x92	NVM_RANK_SHR1	R/W	-	-	BUCK2_RANK[2:0]			BUCK1_RANK[2:0]			
0x96	NVM_RANK_SHR5	R/W	-	-	LDO2_RANK[2:0]			-	-	-	-

hex	Register Name	R/W	BITS[7:0]								
			7	6	5	4	3	2	1	0	
Status registers											
0x97	NVM_RANK_SHR6	R/W	-	-	LDO4_RANK[2:0]			LDO3_RANK[2:0]			
0x98	RANK_SHR7	R/W	-	-	-	-	-	LDO5_RANK[2:0]			
0x9A	NVM_BUCK_MODE_SHR1	R/W	-	-	-	-	BUCK2_PREG_MODE[1:0]		BUCK1_PREG_MODE[1:0]		
0x9C	NVM_BUCK1_VOUT_SHR	R/W	BUCK1_VRANGE_CFG		NVM_VOUT[6:0]						
0x9D	NVM_BUCK2_VOUT_SHR	R/W	BUCK2_VRANGE_CFG		NVM_VOUT[6:0]						
0x9F	NVM_MAIN_CTRL_SHR3	R/W	-	-	-	-	-	-	GPO2_POL	GPO1_POL	
0xA0	NVM_RANK_SHR9	R/W	-	GPO2_RANK[2:0]				GPO1_RANK[2:0]			
0xA3	NVM_LDO2_SHR	R/W	-	-	NVM_VOUT[4:0]				-		
0xA4	NVM_LDO3_SHR	R/W	SNK_RSC	-	NVM_VOUT[4:0]				-		
0xA5	NVM_LDO5_SHR	R/W	-	-	NVM_VOUT[4:0]				-		
0xA9	NVM_PD_SHR1	R/W	-	-	-	-	NVM_BUCK2_PD[1:0]		NVM_BUCK1_PD[1:0]		
0xAB	NVM_PD_SHR3	R/W	-	-	-	NVM_LDO5_PD	NVM_LDO4_PD	NVM_LDO3_PD	NVM_LDO2_PD	-	
0xAC	NVM_BUCKS_IOUT_SHR1	R/W	-	-	-	-	BUCK2_ILIM[1:0]		BUCK1_ILIM[1:0]		
0xAD	NVM_BUCKS_IOUT_SHR2	R/W	HICCUP_DLY[1:0]		-	-	-	-	-	-	
0xAE	NVM_LDOS_IOUT_SHR	R/W	-	-	-	-	LDO5_ILIM[1:0]		LDO2_ILIM[1:0]		
0xAF	NVM_FS_OCP_SHR1	R/W	-	-	-	-	-	-	NVM_FS_OCP_BUCK2	NVM_FS_OCP_BUCK1	
0xB0	NVM_FS_OCP_SHR2	R/W	-	-	-	NVM_FS_OCP_LDO5	NVM_FS_OCP_LDO4	NVM_FS_OCP_LDO3	NVM_FS_OCP_LDO2	-	
0xB1	NVM_FS_SHR1	R/W	VIN_FLT_CNT_MAX[3:0]				PKEY_FLT_CNT_MAX[3:0]				
0xB2	NVM_FS_SHR2	R/W	TSHDN_FLT_CNT_MAX[3:0]				OCP_FLT_CNT_MAX[3:0]				
0xB3	NVM_FS_SHR3	R/W	-	FS_LOCK_DIS	RST_FLT_CNT_TMR[1:0]		WDG_FLT_CNT_MAX[3:0]				

hex	Register Name	R/W	BITS[7:0]							
			7	6	5	4	3	2	1	0
Status registers										
0xB5	NVM_I ² C_ADDR_SHR	R/W	LOCK_NVM	I ² C_ADDR[6:0]						
0xB6	NVM_USER_SHR1	R/W	NVM_USER1[7:0]							
0xB7	NVM_USER_SHR2	R/W	NVM_USER2[7:0]							
0xB9	NVM_MAIN_CTRL_SHR4	R/W	VIN_DLY[1:0]	-	NVM_PKEY_EN_PULL[1:0]		EN_POL_CFG	PKEY_EN_CFG		

6.2 Status registers

6.2.1 Product ID status register (PRODUCT_ID_SR)

Table 27. PRODUCT_ID_SR

7	6	5	4	3	2	1	0
PMIC_REF_ID [3:0]				PMIC_NVM_ID [3:0]			
R	R	R	R	R	R	R	R

- Address: 0x00
- Default: 0x1X (X depends on the PMIC variant)
- Description: PMIC product ID status register.

[7:4]	PMIC_REF_ID [3:0]: PMIC family of devices 0001: STPMIC1L product family (fixed value)
[3:0]	Version A and B only 0000: customized 0001: A 0002: B 0011: reserved

6.2.2 Version status register (VERSION_SR)

Table 28. . VERSION_SR

7	6	5	4	3	2	1	0
MAJOR_VERSION [3:0]				MINOR_VERSION [3:0]			
R	R	R	R	R	R	R	R

- Address: 0x01
- Default: 0x11
- Description: PMIC version status register.

[7:4]	MAJOR_VERSION [3:0]
[3:0]	MINOR_VERSION [3:0]

6.2.3 Turn-on status register (TURN_ON_SR)

Table 29. TURN_ON_SR

7	6	5	4	3	2	1	0
-	-	-	-	AUTO	-	-	PKEY_EN
R	R	R	R	R	R	R	R

- Address: 0x02
- Default: 0b0000x00x where x depends on the turn-on condition
- Description: Stores last condition, which has turned on the PMIC.

From the NO_SUPPLY state, if the AUTO_TURN_ON bit is set in the NVM, the TURN_ON_SR [AUTO] is set. In the OFF state, the TURN_ON_SR is cleared. When a turn-on condition occurs, the related turn-on bit is set in TURN_ON_SR before leaving the OFF state.

The TURN_ON_SR is cleared in the POWER_DOWN state.

[7:4]	reserved
[3]	AUTO: The PMIC turn-on condition is triggered by the AUTO_TURN_ON bit in the NVM. See Section 5.4.5 AUTO turn-ON. 0: False 1: True
[2]	reserved
[1]	reserved
[0]	PKEY_EN: The PMIC turn-on condition is triggered by the PONKEYn or EN signals. See Section 5.4.5 0: False 1: True

6.2.4 Turn-off status register (TURN_OFF_SR)

Table 30. TURN_OFF_SR

7	6	5	4	3	2	1	0
EN	-	WDG_FLT	TSHDN_FLT	OCF_FLT	VIN_FLT	PKEY_FLT	SWOFF
R	R	R	R	R	R	R	R

- Address: 0x03
- Default: 0bx0xxxxx, where x depends on the turn-off condition
- Description: Stores last condition, which turns off the PMIC.

The TURN_OFF_SR register is reset in the POWER_DOWN state. Then TURN_OFF_SR is set either when going into the OFF state or when going into the FAIL_SAFE_LOCK state (see [Section 5.4.6](#) and [Section 5.1.2](#)).

[7]	EN : Last turn-off is due to EN de-activation. (PKEY_EN_CFG bit is set, and PONKEYn/EN pad is deasserted depending on EN_POL_CFG) 0: False 1: True
[6]	reserved
[5]	WDG_FLT : Last turn-off is due to watchdog hard-fault source while WDG_FLT_CNT > WDG_FLT_CNT_MAX. 0: False 1: True
[4]	TSHDN_FLT : Last turn-off is due to thermal shutdown hard-fault source while TSHDN_FLT_CNT > TSHDN_FLT_CNT_MAX. 0: False 1: True
[3]	OCF_FLT : Last turn-off is due to regulator overcurrent hard-fault source while OCF_FLT_CNT > OCF_FLT_CNT_MAX. 0: False 1: True
[2]	VIN_FLT : Last turn-off is due to VIN falling below VINOK_Fall hard-fault source while VIN_FLT_CNT > VIN_FLT_CNT_MAX. (This is valid only if VIN is kept higher than VINPOR_Fall, or the PMIC fully resets) 0: False 1: True
[1]	PKEY_FLT : Last turn-off is due to PONKEYn long key press hard-fault source while PKEY_FLT_CNT > PKEY_FLT_CNT_MAX. 0: False 1: True
[0]	SWOFF : Last turn-off is due to software switch-OFF (SWOFF bit set and RREQ_EN bit clear in the MAIN_CR register). 0: False 1: True

6.2.5 Restart status register (RESTART_SR)

Table 31. RESTART_SR

7	6	5	4	3	2	1	0
R_EN	R_RST	R_WDG_FLT	R_TSHDN_FLT	R_OCP_FLT	R_VIN_FLT	R_PKEY_FLT	R_SWOFF
R	R	R	R	R	R	R	R

- Address: 0x04
- Default: 0bxxxxxxx, where x depends on a power-OFF condition which restarts the PMIC
- Description: Stores last condition, which restarts the PMIC (power cycle).

The RESTART_SR register is reset in the POWER_DOWN state. Then RESTART_SR is set when going into the CHECK&LOAD state (see [Section 5.4.6](#) and [Section 5.1.2](#)).

[7]	<p>R_EN: Last restart is due to EN pin activation (PKEY_EN_CFG bit is set, and PONKEYn/EN pad asserted depending on EN_POL_CFG)</p> <p>0: False 1: True</p>
[6]	<p>R_RST: Last restart is due to RSTn pin asserted low by the application processor (or by a user reset button)</p> <p>0: False 1: True</p>
[5]	<p>R_WDG_FLT: Last restart is due to watchdog hard-fault source while WDG_FLT_CNT <= WDG_FLT_CNT_MAX.</p> <p>0: False 1: True</p>
[4]	<p>R_TSHDN_FLT: Last restart is due to thermal shutdown hard-fault source while TSHDN_FLT_CNT <= TSHDN_FLT_CNT_MAX.</p> <p>0: False 1: True</p>
[3]	<p>R_OCP_FLT: Last restart is due to regulator overcurrent hard-fault source while OCP_FLT_CNT <= OCP_FLT_CNT_MAX. (overcurrent source is saved in OCP_SR1 or in OCP_SR2)</p> <p>0: False 1: True</p>
[2]	<p>R_VIN_FLT: Last restart is due to VIN falling below VINOK_Fall hard-fault source while VIN_FLT_CNT <= VIN_FLT_CNT_MAX. (This is valid only if VIN is kept higher than VINPOR_Fall, or PMIC fully resets)</p> <p>0: False 1: True</p>
[1]	<p>R_PKEY_FLT: Last restart is due to PONKEYn long key press hard-fault source while PKEY_FLT_CNT <= PKEY_FLT_CNT_MAX.</p> <p>0: False 1: True</p>
[0]	<p>R_SWOFF: Last restart is due to a restart request from AP:</p> <ul style="list-style-type: none"> • setting both SWOFF and RREQ_EN bits in MAIN_CR register if PONKEYn is set in PKEY_EN_CFG NVM register. • setting SWOFF bit and EN is asserted if EN is set in PKEY_EN_CFG NVM register. <p>0: False 1: True</p>

6.2.6 Overcurrent protection status register 1 (OCP_SR1)

Table 32. Overcurrent protection status register 1 (OCP_SR1)

7	6	5	4	3	2	1	0
-	-	-	-	-	-	OCP_BUCK2	OCP_BUCK1
R	R	R	R	R	R	R	R

- Address: 0x05
- Default: 0b000000xx, where x depends on regulator that has triggered the OCP.
- Description: If the PMIC is turned OFF or restarted due to an OCP from regulator, OCP_SR1 or OCP_SR2 store the regulator instance that triggered the OCP.

The OCP_SR1 register is reset in the POWER_DOWN state. If an OCP hard-fault condition occurred, then the OCP_SR1 register is set before leaving the POWER_DOWN state (see [Section 5.4.6.1](#) and [Section 5.4.6](#) and [Section 5.1.2](#)).

[7:2]	reserved
[1]	OCP_BUCK2: Last turn-off or restart is due to overcurrent protection on BUCK2. 0: False 1: True
[0]	OCP_BUCK1: Last turn-off or restart is due to overcurrent protection on BUCK1. 0: False 1: True

6.2.7 Overcurrent protection status register 2 (OCP_SR2)

Table 33. Overcurrent protection status register 2 (OCP_SR2)

7	6	5	4	3	2	1	0
-	-	-	OCP_LDO5	OCP_LDO4	OCP_LDO3	OCP_LDO2	-
R	R	R	R	R	R	R	R

- Address: 0x06
- Default: 0b000xxxx0, where x depends on regulator that has triggered the OCP.
- Description: If the PMIC is turned OFF or is restarted due to an OCP from a regulator, OCP_SR1 or OCP_SR2 store the regulator instance that triggered the OCP.

The OCP_SR2 register is reset in the POWER_DOWN state. If an OCP hard-fault condition occurred, then the OCP_SR2 register is set before leaving the POWER_DOWN state (see [Section 5.4.6.1](#) and [Section 5.4.6](#) and [Section 5.1.2](#)).

[7:5]	reserved
[4]	OCP_LDO5: Last turn-off or restart is due to overcurrent protection on LDO5. 0: False 1: True
[3]	OCP_LDO4: Last turn-off or restart is due to overcurrent protection on LDO4. 0: False 1: True
[2]	OCP_LDO3: Last turn-off or restart is due to overcurrent protection on LDO3. 0: False 1: True
[1]	OCP_LDO2: Last turn-off or restart is due to overcurrent protection on LDO2. 0: False 1: True
[0]	reserved

6.2.8 Enable status register 1 (EN_SR1)

Table 34. EN_SR1

7	6	5	4	3	2	1	0
-	-	-	-	-	-	EN_BUCK2	EN_BUCK1
R	R	R	R	R	R	R	R

- Address: 0x07
- Default: 0b000000xx, where x depends on regulator status (0 = disabled, 1 = enabled)
- Description: This register reflects the IP current enable status despite the setting in MAIN or ALT configurations.

[7:2]	reserved
[1]	EN_BUCK2 : Current internal enable status of BUCK2. 0: Disabled 1: Enabled
[0]	EN_BUCK1 : Current internal enable status of BUCK1. 0: Disabled 1: Enabled

6.2.9 Enable status register 2 (EN_SR2)

Table 35. EN_SR2

7	6	5	4	3	2	1	0
-	-	-	EN_LDO5	EN_LDO4	EN_LDO3	EN_LDO2	-
R	R	R	R	R	R	R	R

- Address: 0x08
- Default: 0b000xxxx0, where x depends on regulator status (0 = disabled, 1 = enabled)
- Description: This register reflects the IP current enable status despite the setting in MAIN or ALT configurations.

[7:5]	reserved
[4]	EN_LDO5 : Current internal enable status of LDO5. 0: Disabled 1: Enabled
[3]	EN_LDO4 : Current internal enable status of LDO4. 0: Disabled 1: Enabled
[2]	EN_LDO3 : Current internal enable status of LDO3. 0: Disabled 1: Enabled
[1]	EN_LDO2 : Current internal enable status of LDO2. 0: Disabled 1: Enabled
[0]	reserved

6.2.10 Fail-safe counter status register 1 (FS_CNT_SR1)

Table 36. FS_CNT_SR1

7	6	5	4	3	2	1	0
VIN_FLT_CNT [3:0]				PKEY_FLT_CNT [3:0]			
R	R	R	R	R	R	R	R

- Address: 0x09
- Default: 0x00
- Description: Fail-safe counters store the number of hard-fault occurrences. There is one fail-safe counter per hard-fault source (see Section 5.4.6). FS_CNT_SR1 is reset in the OFF state.

[7:4]	VIN_FLT_CNT [3:0] : number of occurrences triggered by V _{IN} falling below VINOK_Fall hard-fault source. (This is valid only if V _{IN} is kept higher than VINPOR_Fall, or PMIC fully resets)
[3:0]	PKEY_FLT_CNT [3:0] : number of occurrences triggered by a PONKEYn long key press hard-fault source.

Note: When a counter (xxx_FLT_CNT [3:0]) reaches 0xF, all following counter increments keep the counter value at 0xF (and not restart to 0).

6.2.11 Fail-safe counter status register 2 (FS_CNT_SR2)

Table 37. FS_CNT_SR2

7	6	5	4	3	2	1	0
TSHDN_FLT_CNT [3:0]				OCP_FLT_CNT [3:0]			
R	R	R	R	R	R	R	R

- Address: 0x0A
- Default: 0x00
- Description: Fail-safe counters store the number of hard-fault occurrences. There is one fail-safe counter per hard-fault source (see Section 5.4.6). FS_CNT_SR2 is reset in the OFF state.

[7:4]	TSHDN_FLT_CNT [3:0] : Number of occurrences triggered by a thermal shutdown hard-fault source.
[3:0]	OCP_FLT_CNT [3:0] : Number of occurrences triggered by regulator overcurrent hard-fault source.

Note: When a counter (xxx_FLT_CNT [3:0]) reaches 0xF, all following counter increments keep the counter value at 0xF (and not restart to 0).

6.2.12 Fail-safe counter status register 3 (FS_CNT_SR3)

Table 38. FS_CNT_SR3

7	6	5	4	3	2	1	0
-	-	-	-	WDG_FLT_CNT [3:0]			
R	R	R	R	R	R	R	R

- Address: 0x0B
- Default: 0x00
- Description: Fail-safe counters store the number of hard-fault occurrences. There is one fail-safe counter per hard-fault source (see Section 5.4.6). FS_CNT_SR3 is reset in OFF state.

[7:4]	reserved
[3:0]	WDG_FLT_CNT [3:0] : Number of occurrences triggered by watchdog hard-fault source.

Note: When a counter (*xxx_FLT_CNT [3:0]*) reaches 0xF, all following counter increments keep the counter value at 0xF (and not restart to 0).

6.2.13 Mode status register (MODE_SR)

Table 39. MODE_SR

7	6	5	4	3	2	1	0
OP_MODE [3:0]				-	-	PWRCTRL2	PWRCTRL1
R	R	R	R	R	R	R	R

- Address: 0x0C
- Default: 0bxxxx00xx, where x depends on source state
- Description: Contains the current state of the related source.

[7:4]	OP_MODE : PMIC operating state 0000: PMIC is in POWER_ON state 0001: RESERVED 0010: PMIC is in INIT&LOAD state 0100: PMIC is in OFF state 0110: PMIC is in CHECK&LOAD state 1000: PMIC is in POWER_UP state 1110: PMIC is in WAIT_RSTREL state 1010: PMIC is in POWER_DOWN state 1100: PMIC is in FAIL_SAFE_LOCK state
[3:2]	reserved
[1]	PWRCTRL2 : logic state of the PWRCTRL2 input (see Table 26. Register data format) 0: PWRCTRL2 is active 1: PWRCTRL2 is inactive
[0]	PWRCTRL1 : logic state of the PWRCTRL1 input (see Table 26. Register data format) 0: PWRCTRL1 is active 1: PWRCTRL1 is inactive

6.2.14 GPO status register (GPO_SR)

Table 40. GPO_SR

7	6	5	4	3	2	1	0
-				-	-	GPO2_EN	GPO1_EN
R	R	R	R	R	R	R	R

- Address: 0x0D
- Default: 0b000000xx, where x depends on source state
- Description: Contains the current state of the related GPO.

[7:2]	reserved
[1]	GPO2_EN : logic state of the GPO2 input: 0: GPO2 is inactive 1: GPO2 is active
[0]	GPO1_EN : logic state of the GPO1 input: 0: GPO1 is inactive 1: GPO1 is active

6.3 Control registers

6.3.1 Main control register (MAIN_CR)

Table 41. MAIN_CR

7	6	5	4	3	2	1	0
-	-	-	-	PWRCTRL2_POL	PWRCTRL1_POL	RREQ_EN	SWOFF
R	R/W	R/W	R	R/W	R/W	R/W	R/W

- Address: 0x10
- Default: 0b00000000
- Description: Main control register (see Table 26). This register is initialized to the default value in the CHECK&LOAD state.

[7:4]	Reserved
[3]	PWRCTRL2_POL : Specifies PWRCTRL2 pin polarity. 0: PWRCTRL2 active low 1: PWRCTRL2 active high (see Table 26)
[2]	PWRCTRL1_POL : Specifies PWRCTRL1 pin polarity. 0: PWRCTRL1 active low 1: PWRCTRL1 active high (see Table 26)
[1]	RREQ_EN : Allows the PMIC power cycle when the software switch OFF bit is (SWOFF) set. 0: PMIC goes in OFF state when SWOFF bit is set 1: PMIC performs a power cycle when the SWOFF bit is set <i>Note: If EN is set in the PKEY_EN_CFG NVM register, this bit has no effect and is automatically cleared.</i>
[0]	SWOFF : Software switch OFF bit. 0: No effect 1: Switch-OFF requested (turn-off condition). The PMIC goes into the POWER_DOWN state immediately.

6.3.2 VINLOW monitoring control register (VINLOW_CR)

Table 42. VINLOW_CR

7	6	5	4	3	2	1	0
-	-	VINLOW_HYST [1:0]		VINLOW_RISE [2:0]			VINLOW_EN
R	R	R/W	R/W	R/W	R/W	R/W	R/W

- Address: 0x11
- Default: 0x00
- Description: V_{INLOW} monitoring control register (see Section 5.4.1). This register is initialized to the default value in the CHECK&LOAD state.

[7:6]	reserved
[5:4]	VINLOW_HYST [1:0]: VINLOW threshold hysteresis 00: 100 mV 01: 200 mV 10: 300 mV 11: 400 mV
[3:1]	VINLOW_RISE [2:0]: VINLOW_Rise threshold 000: VINOK_Fall + 50 mV 001: VINOK_Fall + 100 mV 010: VINOK_Fall + 150 mV 011: VINOK_Fall + 200 mV 100: VINOK_Fall + 250 mV 101: VINOK_Fall + 300 mV 110: VINOK_Fall + 350 mV 111: VINOK_Fall + 400 mV
[0]	VINLOW_EN: VINLOW monitoring enable bit 0: VINLOW monitoring is disabled 1: VINLOW monitoring is enabled

6.3.3 PONKEYn long key press control register (PKEY_LKP_CR)

Table 43. PKEY_LKP_CR

7	6	5	4	3	2	1	0
PKEY_LKP_OFF	PKEY_LKP_EN_FSLS	-	-	PKEY_LKP_TMR [3:0]			
R/W	R/W	R	R	R/W	R/W	R/W	R/W

- Address: 0x12
- Default: 0bXX00XXXX, where X depends on the value programmed in the NVM
- Description: PONKEYn long key press control register. This register is initialized to the default value in the CHECK&LOAD state.

[7]	PKEY_LKP_OFF: (see Section 5.4.4) 0: no effect 1: A PONKEYn long key press triggers a turn-off condition Default value is defined by NVM_PKEY_LKP_OFF NVM bit
[6]	PKEY_LKP_EN_FSLS: PONKEYn long key press / EN (Enable) as FS_LOCK state skipping 0: no effect 1: A PONKEYn long key press / EN allows the PMIC to go from the FAIL_SAFE_LOCK state to the OFF state Default value is defined by the NVM_PKEY_LKP_EN_FSLS NVM bit
[5:4]	reserved
[3:0]	PKEY_LKP_TMR [3:0]: PONKEYn long key press timer duration 0000: 1 s 0001: 2 s 0010: 3 s 0011: 4 s 0100: 5 s 0101: 6 s 0110: 7 s 0111: 8 s 1000: 9 s 1001: 10 s 1010: 11 s 1011: 12 s 1100: 13 s 1101: 14 s 1110: 15 s 1111: 16 s Default value is defined by the NVM_PKEY_LKP_TMR [1:0] NVM bit field

6.3.4 Watchdog control register (WDG_CR)

Table 44. WDG_CR

7	6	5	4	3	2	1	0
-	-	-	-	WDG_PWRCTRL_SEL[1:0]		WDG_RST	WDG_EN
R	R	R	R	R/W	R/W	W/R0/SC	R/W

- Address: 0x13
- Default: 0b0000000X, where X depends on the value programmed in the NVM
- Description: Watchdog control register (see Section 5.4.6.2). This register is initialized to the default value in the CHECK&LOAD state.

[7:4]	Reserved
[3:2]	WDG_PWRCTRL_SEL [1:0]: Watchdog suspends source selection. 00: No source (if WDG_EN = 1, watchdog timer always runs) 01: PWRCTRL1 WDG suspends control source 10: PWRCTRL2 WDG suspends control source 11: PWRCTRL3 WDG suspends control source When the watchdog is enabled (WDG_EN = 1): If the PWRCTRLx control source is inactive, the watchdog timer runs. If the PWRCTRLx control source is active, the watchdog timer is suspended
[1]	WDG_RST: Watchdog timer reset 0: NA 1: Watchdog down counter WDG_TMR_CNT [7:0] is reloaded with the value in WDG_TMR_SET [7:0] (self-cleared bit)
[0]	WDG_EN: Watchdog enable bit 0: Watchdog is disabled 1: Watchdog is enabled Default value is defined by the NVM_WDG_EN NVM bit

6.3.5 Watchdog timer control register (WDG_TMR_CR)

Table 45. WDG_TMR_CR

7	6	5	4	3	2	1	0
WDG_TMR_SET [7:0]							
R/W	R/W	R/W	R/W	R/W	R/W	W/R0	R/W

- Address: 0x14
- Default: 0xXX, where X depends on the value programmed in NVM
- Description: Watchdog timer control register (see Section 5.4.6.2). This register is initialized to the default value in the CHECK&LOAD state.

[7:0]	WDG_TMR_SET [7:0]: Watchdog timer duration settings: 0x00 = 1 s 0x00 = 2 s ... 0xFF = 256 s Default value is defined by the NVM_WDG_TMR_SET [1:0] NVM bit
-------	---

6.3.6 Watchdog timer status register (WDG_TMR_SR)

Table 46. WDG_TMR_SR

7	6	5	4	3	2	1	0
WDG_TMR_SET [7:0]							
R	R	R	R	R	R	R	R

- Address: 0x15
- Default: 0x00
- Description: Watchdog timer status register. Watchdog down counter providing remaining duration (in seconds) before watchdog expiration.

This register is initialized to the default value in the CHECK&LOAD state.

[7:0]	WDG_TMR_CNT [7:0]: Watchdog timer down counter 0xFF = 256 s ... 0x01 = 2 s 0x00 = 1 s
-------	--

6.3.7 Fail-safe overcurrent protection control register 1 (FS_OCP_CR1)

Table 47. FS_OCP_CR1

7	6	5	4	3	2	1	0
-	-	-	-	-	-	FS_OCP_BUCK2	FS_OCP_BUCK1
R	R	R	R	R	R	R/W	R/W

- Address: 0x16
- Default: 0b000000XX, where X depends on the value programmed in the NVM
- Description: Fail-safe overcurrent protection control registers 1 (see [Section 5.4.6.1](#)). This register is initialized to the default value in the CHECK&LOAD state.

[7:2]	reserved
[1]	FS_OCP_BUCK2: BUCK2 OCP management mode selection. 0: OCP hiccup mode (Level 0) 1: OCP fail-safe PMIC turn-off (Level 1)
[0]	FS_OCP_BUCK1: BUCK1 OCP management mode selection. 0: OCP hiccup mode (Level 0) 1: OCP fail-safe PMIC turn-off (Level 1)

6.3.8 Fail-safe overcurrent protection control register 2 (FS_OCP_CR2)

Table 48. FS_OCP_CR2

7	6	5	4	3	2	1	0
-	-	-	FS_OCP_LDO5	FS_OCP_LDO4	FS_OCP_LDO3	FS_OCP_LDO2	-
R	R	R	R/W	R/W	R/W	R/W	R

- Address: 0x17
- Default: 0b000XXXX0, where X depends on the value programmed in NVM
- Description: Fail-safe overcurrent protection control registers 2 (see [Section 5.4.6.1](#)). This register is initialized to the default value in the CHECK&LOAD state.

[7:5]	reserved
[4]	FS_OCP_LDO5: LDO5 OCP management mode selection. 0: OCP hiccup mode (Level 0) 1: OCP fail-safe PMIC turn-off (Level 1)
[3]	FS_OCP_LDO4: LDO4 OCP management mode selection. 0: OCP hiccup mode (Level 0) 1: OCP fail-safe PMIC turn-off (Level 1)
[2]	FS_OCP_LDO3: LDO3 OCP management mode selection. 0: OCP hiccup mode (Level 0) 1: OCP fail-safe PMIC turn-off (Level 1)
[1]	FS_OCP_LDO2: LDO2 OCP management mode selection. 0: OCP hiccup mode (Level 0) 1: OCP fail-safe PMIC turn-off (Level 1)
[0]	reserved

6.3.9 Pads pull control register (PADS_PULL_CR)

Table 49. PADS_PULL_CR

7	6	5	4	3	2	1	0
-	-	PWRCTRL2_PULL [1:0]		PWRCTRL1_PULL [1:0]		PKEY_EN_PULL [1:0]	
R	R	R/W	R/W	R/W	R/W	R/W	R/W

- Address: 0x18
- Default: 0b000101xx, where xx depends on the value programmed in NVM
- Description: Pads pull control register. This register is initialized to the default value in the CHECK&LOAD state.

[7:6]	reserved
[5:4]	PWRCTRL2_PULL[1:0]: PWRCTRL2 pad pull resistor selection. 00: no pull 01: pull-up active (RPU) 10: pull-down active (RPD) 11: no pull
[3:2]	PWRCTRL1_PULL[1:0]: PWRCTRL1 pad pull resistor selection. 00: no pull 01: pull-up active (RPU) 10: pull-down active (RPD) 11: no pull
[1:0]	PKEY_EN_PULL[1:0]: PKEYn/EN pad pull resistor selection. 00: no pull 01: pull-up active (RPU) 10: pull-down active (RPD) 11: no pull Default value is defined by NVM_PKEY_EN_PULL[1:0] NVM bit

6.3.10 Buck pull-down control register 1 (BUCKS_PD_CR)

Table 50. . BUCKS_PD_CR

7	6	5	4	3	2	1	0
-	-	-	-	BUCK2_PD [1:0]		BUCK1_PD [1:0]	
R	R	R	R	R/W	R/W	R/W	R/W

- Address: 0x19
- Default: 0b0000XXXX, where X depends on the value programmed in the NVM
- Description: Buck pull-down control register 1. This register is initialized to the default value in the INIT&LOAD and in the CHECK&LOAD states.

[7:4]	reserved
[3:2]	<p>BUCK2_PD [1:0]: Default value is defined by NVM_BUCK2_PD [1:0] NVM bit. BUCK2 pull-down selection.</p> <p>00: no pull-down 01: slow pull-down active when BUCK2 is disabled (EN = 0) 10: fast pull-down active when BUCK2 is disabled (EN = 0) 11: slow pull-down forced active</p>
[1:0]	<p>BUCK1_PD [1:0]: Default value is defined by NVM_BUCK1_PD [1:0] NVM bit. BUCK1 pull-down selection.</p> <p>00: no pull-down 01: slow pull-down active when BUCK1 is disabled (EN = 0) 10: fast pull-down active when BUCK1 is disabled (EN = 0) 11: slow pull-down forced active</p>

6.3.11 LDO pull-down control register (LDOS_PD_CR)
Table 51. LDOS_PD_CR

7	6	5	4	3	2	1	0
-	-	-	LDO5_PD	LDO4_PD	LDO3_PD	LDO2_PD	-
R	R	R	R/W	R/W	R/W	R/W	R

- Address: 0x1B
- Default: 0b000XXXX0, where X depends on the value programmed in NVM
- Description: LDO pull-down control register. This register is initialized to the default value in the INIT&LOAD and in the CHECK&LOAD states.

[7:5]	reserved
[4]	LDO5_PD : Default value is defined by NVM_LDO5_PD [1:0] NVM bit. 0: no pull-down 1: pull-down active when LDO5 is disabled (EN = 0)
[3]	LDO4_PD : Default value is defined by NVM_LDO4_PD [1:0] NVM bit. 0: no pull-down 1: pull-down active when LDO4 is disabled (EN = 0)
[2]	LDO3_PD : Default value is defined by NVM_LDO3_PD [1:0] NVM bit. 0: no pull-down 1: pull-down active when LDO3 is disabled (EN = 0)
[1]	LDO2_PD : Default value is defined by NVM_LDO2_PD [1:0] NVM bit. 0: no pull-down 1: pull-down active when LDO2 is disabled (EN = 0)
[0]	reserved

6.3.12 Mask reset GPO control register (GPO_MRST_CR)

Table 52. GPO_MRST_CR

7	6	5	4	3	2	1	0
-	-	-	-	-	GPO2_MRST	GPO1_MRST	-
R	R	R	R	R	R/W	R/W	R

- Address: 0x1C; user page
- Default: 0x00
- Description: mask reset GPO control register.

This register is initialized to default value in CHECK&LOAD states; writable in POWER_ON states only.

[7:3]	-	Reserved; read as 0
[2]	GPO2_MRST	GPO2 mask reset setting For every bit: 0: mask reset inactive for GPO2 1: mask reset active for GPO2
[1]	GPO1_MRST	GPO1 mask reset setting For every bit: 0: mask reset inactive for GPO1 1: mask reset active for GPO1
[0]	-	Reserved; read as 0

6.3.13 Mask reset buck control register (BUCKS_MRST_CR)

Table 53. BUCKS_MRST_CR

7	6	5	4	3	2	1	0
-	-	-	-	-	-	BUCK2_MRST	BUCK1_MRST
R	R	R	R	R	R	R/W	R/W

- Address: 0x1D
- Default: 0x00
- Description: Mask reset buck control register.

See Section 5.4.13.1. This register is initialized to the default value in the CHECK&LOAD state and writable in POWER_ON states only.

[7:2]	reserved
[1]	BUCK2_MRST : Mask reset setting 0: inactive 1: active
[0]	BUCK1_MRST : Mask reset setting 0: inactive 1: active

6.3.14 Mask reset LDO control register (LDOS_MRST_CR)

Table 54. LDOS_MRST_CR

7	6	5	4	3	2	1	0
-	-	-	LDO5_MRST	LDO4_MRST	LDO3_MRST	LDO2_MRST	-
R	R	R	R/W	R/W	R/W	R/W	R

- Address: 0x1E
- Default: 0x00
- Description: Mask reset LDO control register.

See [Section 5.4.13.1](#). This register is initialized to the default value in the CHECK&LOAD state and writable in POWER_ON states only.

[7:5]	reserved
[4]	LDO5_MRST : Mask reset setting 0: inactive 1: active
[3]	LDO4_MRST : Mask reset setting 0: inactive 1: active
[2]	LDO3_MRST : Mask reset setting 0: inactive 1: active
[1]	LDO2_MRST : Mask reset setting 0: inactive 1: active
[0]	reserved

6.4 Power supply control registers

6.4.1 BUCKx MAIN mode control register 1 (BUCKx_MAIN_CR1) (x = 1 to 2)

Table 55. BUCKx_MAIN_CR1

7	6	5	4	3	2	1	0
-	VOUT [6:0]						
R	R/W	R/W	R/W	R/W	R/W	R/W	R/W

- Address: 0x20/0x25
- Default: 0b0XXXXXXX, where X depends on the value programmed in the NVM
- Description: BUCK1 to BUCK2 MAIN mode control register 1.

This register is initialized to the default value in the CHECK&LOAD state. The user can write to this register to set the voltage of BUCKx, which is applied to the MAIN mode (see [Section 5](#)).

[7]	reserved
[6:0]	VOUT [6:0]: Buck output voltage settings. See Table 1. BUCK output voltage settings. The default value is defined in the BUCKx_VOUT [2:0] bit field of NVM_BUCKx_VOUT_SHR NVM shadow registers.

6.4.2 BUCKx MAIN mode control register 2 (BUCKx_MAIN_CR2) (x = 1 to 2)

Table 56. BUCKx_MAIN_CR2

7	6	5	4	3	2	1	0
-	-	-	-	-	PREG_MODE [1:0]		EN
R	R	R	R	R	R/W	R/W	R/W

- Address: 0x21/0x26
- Default: 0b00000XXX, where X depends on the value programmed in NVM
- Description: BUCK1 to BUCK2 MAIN mode control register 2.

This register is initialized to the default value in the CHECK&LOAD state. The user can write to this register to control the enable and regulation modes of BUCKx, which are applied to the MAIN mode (see Feature descriptions).

[7:3]	reserved
[2:1]	PREG_MODE: Default value is defined by NVM_BUCKx_PREG_MODE NVM bit. Select regulation mode 00: BUCKx operates in normal mode (HP) 01: reserved 10: BUCKx operates in forced PWM mode (CCM) 11: reserved
[0]	EN: 0: BUCKx is disabled 1: BUCKx is enabled Default value is defined in the BUCKx_RANK [2:0] bit field of NVM_BUCKx_RANK_SHR NVM shadow registers. If BUCKx_RANK [2:0] = 0, BUCKx is disabled at power up; if BUCKx_RANK [2:0] = y (with 6 > y > 0), BUCKx is enabled at power up at rank y (see Section 5.2)

6.4.3 BUCKx ALTERNATE mode control register 1 (BUCKx_ALT_CR1) (x = 1 to 2)

Table 57. BUCKx_ALT_CR1

7	6	5	4	3	2	1	0
-	VOUT [6:0]						
R	R/W	R/W	R/W	R/W	R/W	R/W	R/W

- Address: 0x22/0x27
- Default: 0b0XXXXXXX, where X depends on the value programmed in NVM
- Description: BUCK1 to BUCK ALT mode control register 1.

This register is initialized to the default value in the CHECK&LOAD state. The user can write to this register to set the voltage of BUCKx, which is applied to the ALTERNATE mode (see Section 5.4.5.1).

[7]	reserved
[6:0]	VOUT [6:0]: Buck output voltage settings. See Table 20. The default value is the same as BUCKx_MAIN_CR1

6.4.4 BUCKx ALTERNATE mode control register 2 (BUCKx_ALT_CR2) (x = 1 to 2)

Table 58. BUCKx_ALT_CR2

7	6	5	4	3	2	1	0
-	-	-	-	-	PREG_MODE [1:0]		EN
R	R	R	R	R	R/W	R/W	R/W

- Address: 0x23/0x28
- Default: 0b00000XXX, where X depends on the value programmed in NVM
- Description: BUCK1 to BUCK2 ALTERNATE mode control register 2.

This register is initialized to the default value in the CHECK&LOAD state. The user can write to this register to control the enable and regulation modes of BUCKx, which are applied to the ALTERNATE mode (see Section 5.4.5.1).

[7:3]	reserved
[2:1]	PREG_MODE [1:0]: select regulation mode 00: BUCKx operates in normal mode (HP) 01: reserved 10: BUCKx operates in forced PWM mode (CCM) 11: Reserved
[0]	EN: 0: BUCKx is disabled 1: BUCKx is enabled The default value is the same as BUCKx_MAIN_CR2

6.4.5 BUCKx PWRCTRL control register (BUCKx_PWRCTRL_CR) (x = 1 to 2)

Table 59. BUCKx_PWRCTRL_CR

7	6	5	4	3	2	1	0
PWRCTRL_DLY_H [1:0]		PWRCTRL_DLY_L [1:0]		PWRCTRL_SEL [1:0]		PWRCTRL_RST	PWRCTRL_EN
R/W	R/W	R/W	R/W	R/W	R/W	R/W	R/W

- Address: 0x24/0x29
- Default: 0x00
- Description: BUCK1 to BUCK2 PWRCTRL control register.

This register is initialized to the default value in the CHECK&LOAD state. The user can write to this register to allocate a PWRCTRL signal for controlling the BUCKx (see Section 5.4.5.1).

[7:6]	PWRCTRL_DLY_H [1:0]: BUCKx control/reset source shift delay from low to High level 00: no delay 01: 1.5 ms delay 10: 3 ms delay 11: 6 ms delay
[5:4]	PWRCTRL_DLY_L [1:0]: BUCKx control/reset source shift delay from high to Low level 00: no delay 01: 1.5 ms delay 10: 3 ms delay 11: 6 ms delay
[3:2]	PWRCTRL_SEL[1:0]: BUCKx control/reset PWRCTRL source selection 00: no control source 01: PWRCTRL1 control source 10: PWRCTRL2 control source 11: reserved
[1]	PWRCTRL_RST: BUCKx independent reset source enable 0: no effect 1: reset enable (when the selected PWRCTRL source is active, BUCKx is disabled and the BUCKx control registers are reset to the default value. When the selected PWRCTRL source is inactive, BUCKx operates according to BUCKx_MAIN_CR1 / 2. See Table 27).
[0]	PWRCTRL_EN: BUCKx control source enable 0: disable (BUCKx operates according to BUCKx_MAIN_CR1 / 2) 1: enable (BUCKx operates according to BUCKx_MAIN_CR1 / 2 or BUCKx_ALT_CR1 / 2 depending on the PWRCTRL selected source. See Table 27).

6.4.6 GPOx MAIN mode control register (GPOx_MAIN_CR) (x = 1, 2)

Table 60. GPOx_MAIN_CR

7	6	5	4	3	2	1	0
-	-	-	-	-	-	-	EN
R	R	R	R	R	R	R	R/W

- Address: 0x43/0x46
- Default: 0b0000000X, where X depends on the value programmed in the NVM
- Description: GPO1 to GPO2 MAIN mode control register.

This register is initialized to the default value in the CHECK&LOAD state. The user can write to this register to control enable of GPOx, which is applied to the MAIN mode (see [Section 5.4.5.1](#)).

[7:1]	reserved
[0]	EN: 0: GPOx is disabled 1: GPOx is enabled The default value is defined in the GPOx_RANK [2:0] bit field of the NVM_GPO_RANK_SHR1 NVM shadow registers. If GPOx_RANK [2:0] = 0, GPOx is disabled at power-up. If GPOx_RANK [2:0] = y (with 6 > y > 0), GPOx is enabled at power-up at rank y (see Section 5.2).

6.4.7 GPOx ALTERNATE mode control register (GPOx_ALT_CR) (x = 1, 2)

Table 61. GPOx_ALT_CR

7	6	5	4	3	2	1	0
-	-	-	-	-	-	-	EN
R	R	R	R	R	R	R	R/W

- Address: 0x44/0x47
- Default: 0b0000000X, where X depends on the value programmed in the NVM
- Description: GPO1 to GPO2 ALTERNATE mode control register.

This register is initialized to the default value in the CHECK&LOAD state. The user can write to this register to control enable of GPOx, which is applied to the ALTERNATE mode (see [Section 5.4.5.1](#)).

[7:1]	reserved
[0]	EN: 0: GPOx is disabled 1: GPOx is enabled The default value is the same as GPOx_MAIN_CR

6.4.8 GPOx PWRCTRL control register (GPOx_PWRCTRL_CR) (x = 1, 2)

Table 62. GPOx_PWRCTRL_CR

7	6	5	4	3	2	1	0
PWRCTRL_DLY_H [1:0]		PWRCTRL_DLY_L [1:0]		PWRCTRL_SEL [1:0]		PWRCTRL_RST	PWRCTRL_EN
R/W	R/W	R/W	R/W	R/W	R/W	R/W	R/W

- Address: 0x45/0x48
- Default: 0x00
- Description: GPO1 to GPO2 PWRCTRL control register.

This register is initialized to the default value in the CHECK&LOAD state. The user can write to this register to allocate a PWRCTRL signal for controlling the GPOx.

[7:6]	PWRCTRL_DLY_H [1:0]: GPOx control/reset source shift delay from low to High level 00: no delay 01: 1.5 ms delay 10: 3 ms delay 11: 6 ms delay
[5:4]	PWRCTRL_DLY_L [1:0]: GPOx control/reset source shift delay from high to Low level 00: no delay 01: 1.5 ms delay 10: 3 ms delay 11: 6 ms delay
[3:2]	PWRCTRL_SEL [1:0]: GPOx control/reset PWRCTRL source selection 00: No control source 01: PWRCTRL1 control source 10: PWRCTRL2 control source 11: reserved
[1]	PWRCTRL_RST: GPOx independent reset source enable 0: no effect 1: reset enable (when the selected PWRCTRL source is active, GPOx is disabled and the GPOx control registers are reset to the default value. When the selected PWRCTRL source is inactive, GPOx operates according to GPOx_MAIN_CR).
[0]	PWRCTRL_EN: GPOx control source enable 0: disable (GPOx operates according to GPOx_MAIN_CR1 / 2) 1: enable (GPOx operates according to GPOx_MAIN_CR or GPOx_ALT_CR depending on the PWRCTRL selected source).

6.4.9 LDOx MAIN mode control register (LDOx_MAIN_CR) (x = 2/5)

Table 63. LDOx_MAIN_CR

7	6	5	4	3	2	1	0
-	-	VOUT [4:0]					EN
R	R	R/W	R/W	R/W	R/W	R/W	R/W

- Address: 0x4F/0x58
- Default: 0b00XXXXXX, where X depends on the value programmed in NVM
- Description: LDO2 and LDO5 MAIN mode control register.

This register is initialized to the default value in the CHECK&LOAD state. The user can write to this register to control enable and set the voltage of the related LDO instance which is applied to the MAIN mode (see Section 5.4.5.1).

[7:6]	reserved
[5:1]	VOUT [4:0]: LDOx output voltage settings. See Section 4.2.4. The default value is defined in the VOUT [4:0] bit field of NVM_LDOx_SHR NVM shadow registers
[0]	EN: 0: LDOx is disabled 1: LDOx is enabled The default value is defined in the LDOx_RANK [2:0] bit field of the NVM_LDOs_RANK_SHR NVM shadow registers. If LDOx_RANK [2:0] = 0, LDOx is disabled at power up; if LDOx_RANK [2:0] = y (with 6 > y > 0), LDOx is enabled at power up at rank y

6.4.10 LDOx ALTERNATE mode control register (LDOx_ALT_CR) (x = 2/5)

Table 64. LDOx_ALT_CR

7	6	5	4	3	2	1	0
-	-	VOUT [4:0]					EN
R	R	R/W	R/W	R/W	R/W	R/W	R/W

- Address: 0x50/0x59
- Default: 0b00XXXXXX, where X depends on the value programmed in the NVM
- Description: LDO2/LDO5 ALTERNATE mode control register.

This register is initialized to the default value in the CHECK&LOAD state. The user can write to this register to control enable and set the voltage of the related LDO instance, which is applied to the ALTERNATE mode (see Section 5.4.5.1).

[7:6]	reserved
[5:1]	VOUT [4:0]: LDOx output voltage settings (See Section 4.2.4); The default value is the same as LDOx_MAIN_CR
[0]	EN: 0: LDOx is disabled 1: LDOx is enabled The default value is the same as LDOx_MAIN_CR

6.4.11 LDOx PWRCTRL control register (LDOx_PWRCTRL_CR) (x = 2 to 5)
Table 65. LDOx_PWRCTRL_CR

7	6	5	4	3	2	1	0
PWRCTRL_DLY_H [1:0]		PWRCTRL_DLY_L [1:0]		PWRCTRL_SEL [1:0]		PWRCTRL_RST	PWRCTRL_EN
R/W	R/W	R/W	R/W	R/W	R/W	R/W	R/W

- Address: 0x51/0x54/0x57/0x5A
- Default: 0x00
- Description: LDO2 to LDO5 PWRCTRL control register.

This register is initialized to the default value in the CHECK&LOAD state. The user can write to this register to allocate a PWRCTRL signal for controlling the LDOx (see [Section 5.4.5.1](#)).

[7:6]	PWRCTRL_DLY_H [1:0]: LDOx control/reset source shift delay from low to High level 00: no delay 01: 1.5 ms delay 10: 3 ms delay 11: 6 ms delay
[5:4]	PWRCTRL_DLY_L [1:0]: LDOx control/reset source shift delay from high to Low level 00: no delay 01: 1.5 ms delay 10: 3 ms delay 11: 6 ms delay
[3:2]	PWRCTRL_SEL[1:0]: LDOx control/reset PWRCTRL source selection. 00: no control source 01: PWRCTRL1 control source 10: PWRCTRL2 control source 11: reserved
[1]	PWRCTRL_RST: LDOx independent reset source enable 0: no effect 1: reset enable (when the selected PWRCTRL source is active, LDOx is disabled and LDOx control registers are reset to the default value. When the selected PWRCTRL source is inactive, LDOx operates according to LDOx_MAIN_CR. See Table 27).
[0]	PWRCTRL_EN: LDOx control source enable 0: disable (LDOx operates according to LDOx_MAIN_CR) 1: enable (LDOx operates according to LDOx_MAIN_CR or LDOx_ALT_CR depending on the PWRCTRL selected source. See Table 27).

6.4.12 LDO3 MAIN mode control register (LDO3_MAIN_CR)
Table 66. LDO3_MAIN_CR

7	6	5	4	3	2	1	0
SNK_SRC	-	VOUT [4:0]					EN
R/W	R	R/W	R/W	R/W	R/W	R/W	R/W

- Address: 0x52
- Default: 0bX0XXXXXX, where X depends on the value programmed in the NVM
- Description: LDO3 MAIN mode control register.

This register is initialized to the default value in the CHECK&LOAD state. The user can write to this register to control enable and SNK_SRC mode, and set the voltage of LDO3, which is applied to the MAIN mode (see Section 5.4.5.1).

[7]	SNK_SRC: Select sink/source mode operation (see Section 4.2.3) 0: LDO3 operates in normal mode 1: LDO3 operates in sink/source mode The default value is defined by the SNK_SRC bit of the NVM_LDO3_SHR NVM shadow register
[6]	reserved
[5:1]	VOUT [4:0]: LDO3 output voltage settings (see Section 4.2.4). The default value is defined in the VOUT [4:0] bit field of the NVM_LDO3_SHR NVM shadow registers
[0]	EN: 0: LDO3 is disabled 1: LDO3 is enabled The default value is defined in the LDO3_RANK [2:0] bit field of the NVM_LDOs_RANK_SHR2 NVM shadow registers. If LDO3_RANK [2:0] = 0, LDO3 is disabled at power up; if LDO3_RANK [2:0] = y (with 6 > y > 0) LDO3 is enabled at power up at rank y (see Section 5.2).

6.4.13 LDO3 ALTERNATE mode control register (LDO3_ALT_CR)

Table 67. LDO3_ALT_CR

7	6	5	4	3	2	1	0
SNK_SRC	-	VOUT [4:0]					EN
R/W	R	R/W	R/W	R/W	R/W	R/W	R/W

- Address: 0x53
- Default: 0bX0XXXXXX, where X depends on the value programmed in the NVM
- Description: LDO3 ALTERNATE mode control register.

This register is initialized to the default value in the CHECK&LOAD state. The user can write to this register to control enable or SNK_SRC mode and set the voltage of LDO3, which is applied to the ALTERNATE mode (see Section 5.4.5.1).

[7]	SNK_SRC: select sink/source mode operation (see Section 4.2.4). 0: LDO3 operates in sink/source mode 1: LDO3 operates in sink/source mode The default value is the same as LDO3_MAIN_CR
[6]	reserved
[5:1]	VOUT [4:0]: LDO3 output voltage settings (see Section 4.2.4). The default value is the same as LDO3_MAIN_CR
[0]	EN: 0: LDO3 is disabled 1: LDO3 is enabled The default value is the same as LDO3_MAIN_CR

6.4.14 LDO4 MAIN mode control register (LDO4_MAIN_CR)

Table 68. LDO4_MAIN_CR

7	6	5	4	3	2	1	0
-	-	-	-	-	-	-	EN
R	R	R	R	R	R	R	R/W

- Address: 0x55
- Default: 0b0000000X, where X depends on the value programmed in the NVM
- Description: LDO4 MAIN mode control register.

This register is initialized to the default value in the CHECK&LOAD state. The user can write to this register to control enable or to force the power input source of LDO4, which is applied to the MAIN mode (see Section 5.4.5.1).

[7:1]	reserved
[0]	EN: 0: LDO4 is disabled 1: LDO4 is enabled The default value is defined in the LDO4_RANK[2:0] bit field of the NVM_LDOs_RANK_SHR2 NVM shadow registers. If LDO4_RANK[2:0] = 0, LDO4 is disabled at power-up. If LDO4_RANK[2:0] = y (with 6 > y > 0), LDO4 is enabled at power-up at rank y (see Section 5.2)

6.4.15 LDO4 ALTERNATE mode control register (LDO4_ALT_CR)

Table 69. LDO4_ALT_CR

7	6	5	4	3	2	1	0
-	-	-	-	-	-	-	EN
R	R	R	R	R	R	R	R/W

- Address: 0x56
- Default: 0b0000000X, where X depends on the value programmed in the NVM
- Description: LDO4 ALTERNATE mode control register.

This register is initialized to the default value in the CHECK&LOAD state. The user can write to this register to control enable or to force the power input source of LDO4, which is applied to the ALTERNATE mode (see Section 5.4.6).

[7:1]	reserved
[0]	EN: 0: LDO4 is disabled 1: LDO4 is enabled The default value is the same as LDO4_MAIN_CR

6.5 Interrupt registers

6.5.1 Interrupt management overview

Interrupts are probed in the POWER_ON state only. All interrupts are masked by default. All interrupt registers are reset to the default value if RSTn is asserted.

INT_PENDING_Rx

- Stores events of interrupt sources, regardless of interrupts masking.
- Corresponding bits are kept set until they are cleared (using INT_CLEAR_Rx registers).

INT_CLEAR_Rx

- Setting a bit in these registers clears the corresponding pending bit in the INT_PENDING_Rx registers. A bit in the INT_PENDING_Rx registers can be cleared only if the corresponding interrupt source disappears. Alternatively, the bit stays set after being cleared. In the case of the INT_PENDING_Rx bit generated by edge triggering, they can be directly deleted without checking the INT_SOURCE_RX.

INT_MASK_Rx

- Clearing a bit in these registers unmask the corresponding interrupt.
- The INTn pin is forced low as long as the corresponding interrupt bit is set in INT_PENDING_Rx.

INT_SOURCE_Rx

- These registers provide the actual state of interrupt sources.
- If an interrupt source is present, the corresponding bit is set. If the interrupt source disappears, the corresponding bit is cleared.

INT_DBG_LATCH_Rx

Setting a bit in these registers emulates the corresponding interrupt event. These registers aim to test and to debug the application processor software interrupt handler.

6.5.2 Interrupt pending register 1 (INT_PENDING_R1)

Table 70. INT_PENDING_R1

7	6	5	4	3	2	1	0
-	-	VINLOW_RI	VINLOW_FA	-	-	PKEY_RI	PKEY_FA
R	R	R	R	R	R	R	R

- Address: 0x70
- Default: 0x00
- Description: Interrupt pending register 1 (see Section 6.5.1). This register is reset to the default value if RSTn is asserted. For all bits:

0: interrupt not pending

1: interrupt pending

[7:6]	reserved
[5]	VINLOW_RI: Voltage on the VIN pin falls below the VINLOW_Rise threshold
[4]	VINLOW_FA: Voltage on the VIN pin rises above the VINLOW_Fall threshold
[3:2]	reserved
[1]	PKEY_RI: PONKEYn rising edge
[0]	PKEY_FA: PONKEYn falling edge

6.5.3 Interrupt pending register 2 (INT_PENDING_R2)

Table 71. INT_PENDING_R2

7	6	5	4	3	2	1	0
-	-	-	-	-	-	THW_RI	THW_FA
R	R	R	R	R	R	R	R

- Address: 0x71
- Default: 0x00
- Description: Interrupt pending register 2 (see Section 6.5.1). This register is reset to the default value as long as RSTn is asserted. For all bits:

0: interrupt not pending

1: interrupt pending

[7:2]	reserved
[1]	THW_RI : Temperature rises above the TWRN_Rise threshold
[0]	THW_FA : Temperature falls below the TWRN_Fall threshold

6.5.4 Interrupt pending register 3 (INT_PENDING_R3)

Table 72. INT_PENDING_R3

7	6	5	4	3	2	1	0
-	-	-	-	-	-	BUCK2_OCP	BUCK1_OCP
R	R	R	R	R	R	R	R

- Address: 0x72
- Default: 0x00
- Description: Interrupt pending register 3 (see Section 6.5.1). This register is reset to the default value if RSTn is asserted. For all bits:

0: interrupt not pending

1: interrupt pending

[7:2]	reserved
[1]	BUCK2_OCP : Overcurrent detected on BUCK2
[0]	BUCK1_OCP : Overcurrent detected on BUCK1

6.5.5 Interrupt pending register 4 (INT_PENDING_R4)

Table 73. INT_PENDING_R4

7	6	5	4	3	2	1	0
-	-	-	LDO5_OCP	LDO4_OCP	LDO3_OCP	LDO2_OCP	-
R	R	R	R	R	R	R	R

- Address: 0x73
- Default: 0x00
- Description: Interrupt mask register 1 to 4 (see [Section 6.5.1](#)). This register is reset to the default value if RSTn is asserted. For all bits:

0: interrupt not pending

1: interrupt pending

[7:5]	reserved
[4]	LDO5_OCP : Overcurrent detected on LDO5
[3]	LDO4_OCP : Overcurrent detected on LDO4
[2]	LDO3_OCP : Overcurrent detected on LDO3
[1]	LDO2_OCP : Overcurrent detected on LDO2
[0]	reserved

6.5.6 Interrupt clear registers (INT_CLEAR_Rx) (x = 1 to 4)

Table 74. INT_CLEAR_Rx

7	6	5	4	3	2	1	0
Same as INT_PENDING_Rx							
W/R0	W/R0	W/R0	W/R0	W/R0	W/R0	W/R0	W/R0

- Address: 0x74/0x75/0x76/0x77
- Default: 0x00
- Description: Interrupt clear registers 1 to 4 (see [Section 6.5.1](#)).

Writing 1 clears the corresponding interrupt bit in INT_PENDING_Rx.

The bit is self-cleared, and always reads 0.

6.5.7 Interrupt mask registers (INT_MASK_Rx) (x = 1 to 4)

Table 75. INT_MASK_Rx

7	6	5	4	3	2	1	0
Same as INT_PENDING_Rx							
R/W	R/W	R/W	R/W	R/W	R/W	R/W	R/W

- Address: 0x78/0x79/0x7A/0x7B
- Default: 0xFF
- Description: Interrupt mask registers 1 to 4 (see [Section 6.5.1](#)).

Writing 0 unmask the corresponding interrupt bit in INT_PENDING_Rx. These registers are reset to the default value if RSTn is asserted.

For all bits:

- 0: interrupt is unmasked
- 1: interrupt is masked

6.5.8 Interrupt source registers (INT_SRC_Rx) (x = 1 to 4)

7	6	5	4	3	2	1	0
Same as INT_PENDING_Rx							
R	R	R	R	R	R	R	R

- Address: 0x7C/0x7D/0x7E/0x7F
- Default: 0xFF, where X depends on the actual state of interrupt sources
- Description: Interrupt source registers 1 to 4 (see [Section 6.5.1](#)).

For all bits:

- 0: interrupt source is not present
- 1: interrupt source is present

6.5.9 Interrupt debug latch registers (INT_DBG_LATCH_Rx) (x = 1 to 4)

Table 76. INT_DBG_LATCH_Rx

7	6	5	4	3	2	1	0
Same as INT_PENDING_Rx							
W/R0	W/R0	W/R0	W/R0	W/R0	W/R0	W/R0	W/R0

- Address: 0x80/0x81/0x82/0x83
- Default: 0x00
- Description: Interrupt debug latch registers 1 to 4 (see [Section 6.5.1](#)).

Setting a bit emulates the corresponding interrupt event. The bit is self-cleared, and always reads 0.

6.6 NVM registers

6.6.1 NVM status register (NVM_SR)

Table 77. NVM_SR

7	6	5	4	3	2	1	0
-	-	-	-	-	-	NVM_WRITE_FAIL	NVM_BUSY
R	R	R	R	R	R	R	R

- Address: 0x8E
- Default: 0x00
- Description: NVM status register.

[7:2]	reserved
[1]	NVM_WRITE_FAIL : Error in writing to the NVM. The LOCK_NVM bit is set. 0: Write is successful or no write operation performed 1: Write to the NVM failed
[0]	NVM_BUSY : NVM controller status 0: NVM controller is in an idle state 0: NVM controller is in an idle state 1: NVM controller is in a busy state Self-cleared when the operation is completed

6.6.2 NVM control register (NVM_CR)

Table 78. NVM_CR

7	6	5	4	3	2	1	0
-	-	-	-	-	-	NVM_CMD[1:0]	
R	R	R	R	R	R	R/W	R/W

- Address: 0x8F
- Default: 0x00
- Description: NVM control register.

[7:2]	reserved
[1:0]	NVM_CMD[1:0] : NVM controller command bits to control the NVM operation on the NVM shadow register bits. 00: No operation 01: Program (write shadow register to the NVM) 10: Read (load NVM content into shadow register) 11: No operation Self-cleared when the operation is completed

6.7 NVM shadow registers

All NVM shadow registers are reloaded from the NVM content in the INIT&LOAD state and in the CHECK&LOAD state. Then mirror registers or mirror bit fields (in Section 6.3 and Section 6.5) are set to the default value

6.7.1 NVM main control shadow register 1 (NVM_MAIN_CTRL_SHR1)

Table 79. NVM_MAIN_CTRL_SHR1

7	6	5	4	3	2	1	0
VINOK_HYST[1:0]		VINOK_RISE[1:0]		NVM_WDG_TMR_SET[1:0]		NVM_WDG_EN	AUTO_TURN_ON
R/W	R/W	R/W	R/W	R/W	R/W	R/W	R/W

- Address: 0x90
- Default: Depends on the PMIC part number
- Description: NVM main control shadow register 1.

[7:6]	VINOK_HYST[1:0]: VINOK_HYST threshold voltage 00: 200 mV 01: 300 mV 10: 400 mV 11: 500 mV
[5:4]	VINOK_RISE[1:0]: VINOK_Rise threshold voltage 00: 3.1 V 01: 3.3 V 10: 3.5 V 11: 4.0 V
[3:2]	NVM_WDG_TMR_SET [1:0]: watchdog timer duration default value 00: 10 s 01: 20 s 10: 50 s 11: 100 s
[1]	NVM_WDG_EN: watchdog default value 0: Watchdog is disabled 1: Watchdog is enabled
[0]	AUTO_TURN_ON: 0: PMIC does not start automatically on VIN rising 1: PMIC starts automatically on VIN rising <i>Note: It is ignored if PKEY_EN_CFG is set to '1'</i>

6.7.2 NVM main control shadow register 2 (NVM_MAIN_CTRL_SHR2)

Table 80. NVM_MAIN_CTRL_SHR2

7	6	5	4	3	2	1	0
RANK_DLY[1:0]	RST_DLY[1:0]	NVM_PKEY_LKP_OFF		NVM_PKEY_LKP_EN_FLS		NVM_PKEY_LKP_TMR[1:0]	
R/W	R/W	R/W	R/W	R/W	R/W	R/W	R/W

Address: 0x91

Default: Depends on the PMIC part number

Description: NVM main control shadow register 2.

[7:6]	<p>RANK_DLY[1:0]: power-up/power-down step (RANK) duration:</p> <p>00: 1.5 ms</p> <p>01: 3 ms</p> <p>10: 4.5 ms</p> <p>11: 6 ms</p> <p>(see Section 5.2)</p>
[5:4]	<p>RST_DLY[1:0]: RST release delay after POWER_UP sequence:</p> <p>00: no delay</p> <p>01: 1.5 ms</p> <p>10: 3 ms</p> <p>11: 6 ms</p> <p>(see Section 5.2)</p>
[3]	<p>NVM_PKEY_LKP_OFF: PONKEYn long key press turn-off condition default value (see Section 5.4.6)</p> <p>0: no effect</p> <p>1: A PONKEYn long key press triggers a turn-off condition</p> <p><i>Note: This bit is valid only if PONKEYn selected (PKEY_EN_CFG = 0)</i></p>
[2]	<p>NVM_PKEY_LKP_EN_FLS : PONKEYn long key press / EN (Enable) fail-safe lock state skipping default value (see Section 5.4.5.1)</p> <p>0: no effect</p> <p>1: A PONKEYn long key press or Enable allows the PMIC to go from the FAIL_SAFE_LOCK state to the OFF state</p>
[1:0]	<p>NVM_PKEY_LKP_TMR[1:0]: PONKEYn long key press timer duration default value</p> <p>00: 2 s</p> <p>01: 5 s</p> <p>10: 10 s</p> <p>11: 15 s</p> <p><i>Note: These bits are valid only if PONKEYn selected (PKEY_EN_CFG = 0)</i></p>

6.7.3 NVM rank shadow register 1 (NVM_RANK_SHR1)

Table 81. NVM_RANK_SHR1

7	6	5	4	3	2	1	0
-	-	BUCK2_RANK[2:0]			BUCK1_RANK[2:0]		
R	R	R/W	R/W	R/W	R/W	R/W	R/W

- Address: 0x92
- Default: Depends on the PMIC part number
- Description: NVM rank shadow register 1 (see Section 5.2).

[7:6]	reserved
[5:3]	BUCK2_RANK[2:0]: 000: rank0 001: rank1 010: rank2 011: rank3 100: rank4 101: rank5 110: rank0 111: rank0
[2:0]	BUCK1_RANK[2:0]: 000: rank0 001: rank1 010: rank2 011: rank3 100: rank4 101: rank5 110: rank0 111: rank0

6.7.4 NVM rank shadow register 5 (NVM_RANK_SHR5)

Table 82. NVM_RANK_SHR5

7	6	5	4	3	2	1	0
-	-	LDO2_RANK[2:0]			-	-	-
R	R	R/W	R/W	R/W	R	R	R

Address: 0x96

Default: Depends on the PMIC part number

Description: NVM rank shadow register 5 (see [Section 5.2](#)).

[7:6]	reserved
[5:3]	LDO2_RANK[2:0]: 000: rank0 001: rank1 010: rank2 011: rank3 100: rank4 101: rank5 110: rank0 111: rank0
[2:0]	reserved

6.7.5 NVM rank shadow register 6 (NVM_RANK_SHR6)

Table 83. NVM_RANK_SHR6

7	6	5	4	3	2	1	0
-	-	LDO4_RANK[2:0]			LDO3_RANK[2:0]		
R	R	R/W	R/W	R/W	R/W	R/W	R/W

- Address: 0x97
- Default: Depends on the PMIC part number
- Description: NVM rank shadow register 6.
Same bit field as [Section 6.1](#)

6.7.6 NVM rank shadow register 7 (NVM_RANK_SHR7)

Table 84. NVM_RANK_SHR7

7	6	5	4	3	2	1	0
-	-	-	-	-	LDO5_RANK[2:0]		
R	R	R	R	R	R/W	R/W	R/W

Address: 0x98

Default: Depends on the PMIC part number

Description: NVM rank shadow register 7.

Same bit field as [Section 6.1](#).

6.7.7 NVM BUCK mode shadow register 1 (NVM_BUCK_MODE_SHR1)

Table 85. NVM_BUCK_MODE_SHR1

7	6	5	4	3	2	1	0
-	-	-	-	BUCK2_PREG_MODE[1:0]		BUCK1_PREG_MODE[1:0]	
R		R		R/W		R/W	

- Address: 0x9A
- Default: Depends on the PMIC part number
- Description: NVM BUCK mode shadow register 1 (see Section 5.2).

[7:4]	reserved
[3:2]	BUCK2_PREG_MODE[1:0]: 00: BUCK2 operates in high power mode (HP) 01: reserved 10: BUCK2 operates in forced PWM mode (CCM) 11: reserved
[1:0]	BUCK1_PREG_MODE[1:0]: 00: BUCK1 operates in high power mode (HP) 01: reserved 10: BUCK1 operates in forced PWM mode (CCM) 11: reserved

6.7.8 NVM BUCK1 output voltage shadow register (NVM_BUCK1_VOUT_SHR)

Table 86. NVM_BUCK1_VOUT_SHR

7	6	5	4	3	2	1	0
BUCK1_VRANGE_CFG		VOUT[6:0]					
R/W	R/W	R/W	R/W	R/W	R/W	R/W	R/W

- Address: 0x9C
- Default: Depends on the PMIC part number
- Description: NVM BUCK1 output voltage shadow registers.

The contents of this register are copied into BUCK1_MAIN_CR1 and BUCK1_ALT_CR1 in the CHECK&LOAD state (see Section 4.3.2).

[7]	BUCK1_VRANGE_CFG: BUCK1 range voltage setting 1: High voltage range 0: Low voltage range
[6:0]	VOUT[6:0]: BUCK1 default output voltage settings. See Table 20.

6.7.9 NVM BUCK2 output voltage shadow register (NVM_BUCK2_VOUT_SHR)

Table 87. NVM_BUCK2_VOUT_SHR

7	6	5	4	3	2	1	0
-	VOUT[6:0]						
R/W	R/W	R/W	R/W	R/W	R/W	R/W	R/W

- Address: 0x9D
- Default: Depends on the PMIC part number
- Description: NVM BUCK2 output voltage shadow registers.

The contents of this register are copied into BUCK2_MAIN_CR1 and BUCK2_ALT_CR1 in the CHECK&LOAD state (see Section 4.3.2).

[7]	reserved
[6:0]	VOUT[6:0] : BUCK2 default output voltage settings. See Section 4.3.2.

6.7.10 GPO Config shadow register (NVM_MAIN_CTRL_SHR3)

Table 88. NVM_MAIN_CTRL_SHR3

7	6	5	4	3	2	1	0
-	-	-	-	-	-	GPO2_POL	GPO1_POL
R	R	R	R	R	R	R/W	R/W

- Address: 0x9F
- Default: Depends on the PMIC part number
- Description: GPO config shadow registers.

[7:2]	reserved
[1]	GPO2_POL : GPO2 Polarity Configuration 0: GPO2 is active high 1: GPO2 is active low
[0]	GPO1_POL : GPO1 Polarity Configuration 0: GPO1 is active high 1: GPO1 is active low

6.7.11 GPO Rank shadow register 1 (NVM_RANK_SHR9)

Table 89. NVM_RANK_SHR9

7	6	5	4	3	2	1	0
-	-	GPO2_RANK[2:0]			GPO1_RANK[2:0]		
R	R	R/W	R/W	R/W	R/W	R/W	R/W

- Address: 0xA0
- Default: Depends on the PMIC part number
- Description: GPO Rank shadow register 1.

[7:6]	reserved
[5:3]	GPO2_RANK[2:0]: 000: rank0 001: rank1 010: rank2 011: rank3 100: rank4 101: rank5 110: rank0 111: rank0
[2:0]	GPO1_RANK[2:0]: 000: rank0 001: rank1 010: rank2 011: rank3 100: rank4 101: rank5 110: rank0 111: rank0

6.7.12 NVM LDOx shadow register (NVM_LDOx_SHR) (x = 2/5)

Table 90. NVM_LDOx_SHR

7	6	5	4	3	2	1	0
-	-	VOUT[4:0]					-
R	R	R/W	R/W	R/W	R/W	R/W	R

- Address: 0xA3/A5
- Default: Depends on the PMIC part number
- Description: NVM LDO2/LDO5 control shadow registers.

The contents of this register are copied into LDOx_MAIN_CR and LDOx_ALT_CR in the CHECK&LOAD state (see Section 5.1.2.4).

[7:6]	reserved
[5:1]	VOUT[4:0] : LDOx default output voltage settings. See Section 4.2.6.
[0]	reserved

6.7.13 NVM LDO3 control shadow register (NVM_LDO3_SHR)

Table 91. NVM_LDO3_SHR

7	6	5	4	3	2	1	0
NVM_SNK_SRC	-	VOUT[4:0]					-
R/W	R	R/W	R/W	R/W	R/W	R/W	R

- Address: 0xA4
- Default: Depends on the PMIC part number
- Description: NVM LDO3 control shadow register.

The content of this register is copied into LDO3_MAIN_CR and LDO3_ALT_CR in the CHECK&LOAD state (see Section 5.1.2.4).

[7]	NVM_SNK_SRC : Select default sink/source mode operation. 0: LDO3 operates in normal mode by default 1: LDO3 operates in sink/source mode by default
[6]	reserved
[5:1]	VOUT[4:0] : LDOx default output voltage settings. See Table 19.
[0]	reserved

6.7.14 NVM pull-down control shadow register 1 (NVM_PD_SHR1)
Table 92. NVM_PD_SHR1

7	6	5	4	3	2	1	0
-	-	-	-	NVM_BUCK2_PD[1:0]		NVM_BUCK1_PD[1:0]	
R	R	R	R	R/W	R/W	R/W	R/W

- Address: 0xA9
- Default: Depends on the PMIC part number
- Description: NVM pull-down control shadow register 1.

The content of this register is copied into BUCKS_PD_CR in the INIT&LOAD and the CHECK&LOAD states.

[7:4]	reserved
[3:2]	NVM_BUCK2_PD[1:0]: BUCK2 pull-down selection. 00: no pull-down 01: slow pull-down active when BUCK2 is disabled (EN = 0) 10: fast pull-down active when BUCK2 is disabled (EN = 0) 11: slow pull-down forced active
[1:0]	NVM_BUCK1_PD[1:0]: BUCK1 pull-down selection. 00: no pull-down 01: slow pull-down active when BUCK1 is disabled (EN = 0) 10: fast pull-down active when BUCK1 is disabled (EN = 0) 11: slow pull-down forced active

6.7.15 NVM pull-down control shadow register 3 (NVM_PD_SHR3)
Table 93. NVM_PD_SHR3

7	6	5	4	3	2	1	0
-	-	-	NVM_LDO5_PD	NVM_LDO4_PD	NVM_LDO3_PD	NVM_LDO2_PD	-
R	R	R	R/W	R/W	R/W	R/W	R

- Address: 0xAB
- Default: Depends on the PMIC part number
- Description: NVM pull-down control shadow register 3.

The content of this register is copied into LDOS_PD_CR in the INIT&LOAD and the CHECK&LOAD states.

[7:5]	reserved
[4]	NVM_LDO5_PD: 0: no pull-down 1: pull-down active when LDO5 is disabled (EN = 0)
[3]	NVM_LDO4_PD: 0: no pull-down 1: pull-down active when LDO4 is disabled (EN = 0)
[2]	NVM_LDO3_PD: 0: no pull-down 1: pull-down active when LDO3 is disabled (EN = 0)
[1]	NVM_LDO2_PD: 0: no pull-down 1: pull-down active when LDO2 is disabled (EN = 0)
[0]	reserved

6.7.16 NVM BUCKs output current limitation shadow register 1 (NVM_BUCKS_IOUT_SHR1)
Table 94. NVM_BUCKS_IOUT_SHR1

7	6	5	4	3	2	1	0
-	-	-	-	BUCK2_ILIM[1:0]		BUCK1_ILIM[1:0]	
R	R	R	R	R/W	R/W	R/W	R/W

- Address: 0xAC
- Default: Depends on the PMIC part number
- Description: NVM BUCKs output current limitation shadow register 1.

[7:4]	reserved
[3:2]	BUCK2_ILIM[1:0]: output current limitation 00: 500 mA 01: 1000 mA 10: 1500 mA 11: 2000 mA
[1:0]	BUCK1_ILIM[1:0]: output current limitation 00: 500 mA 01: 1000 mA 10: 1500 mA 11: 2000 mA

6.7.17 NVM BUCKs output current limitation shadow register 2 (NVM_BUCKS_IOUT_SHR2)
Table 95. NVM_BUCKS_IOUT_SHR2

7	6	5	4	3	2	1	0
HICCUP_DLY[1:0]			-	-	-	-	-
R/W	R/W	R	R	R	R	R	R

- Address: 0xAD
- Default: Depends on the PMIC part number
- Description: NVM BUCKs output current limitation shadow register 2.

[7:6]	HICCUP_DLY[1:0]: output current limitation 00: 0 ms 01: 100 ms 10: 500 ms 11: 1000 ms
[5:0]	reserved

6.7.18 NVM LDOs output current limitation shadow register (NVM_LDOS_IOUT_SHR)

Table 96. NVM_LDOS_IOUT_SHR

7	6	5	4	3	2	1	0
-	-	-	-	LDO5_ILIM[1:0]		LDO2_ILIM[1:0]	
R	R	R	R	R/W	R/W	R/W	R/W

- Address: 0xAE
- Default: Depends on the PMIC part number
- Description: NVM LDOs output current limitation shadow register.

[7:4]	reserved
[3:2]	LDO5_ILIM[1:0]: output current limitation 00: 50 mA 01: 100 mA 10: 200 mA 11: 400 mA
[1:0]	LDO2_ILIM[1:0]: output current limitation 00: 50 mA 01: 100 mA 10: 200 mA 11: 400 mA

6.7.19 NVM fail-safe overcurrent protection shadow register 1 (NVM_FS_OCP_SHR1)

Table 97. NVM_FS_OCP_SHR1

7	6	5	4	3	2	1	0
-	-	-	-	-	-	NVM_FS_OCP_BUCK2	NVM_FS_OCP_BUCK1
R	R	R	R	R	R	R/W	R/W

- Address: 0xAF
- Default: Depends on the PMIC part number
- Description: NVM fail-safe overcurrent protection shadow register 1 (see [Section 5.4.6.1: Turn-OFF condition triggered by software switch-off](#)).

[7:2]	reserved
[1]	<p>NVM_FS_OCP_BUCK2: BUCK2 OCP management mode selection.</p> <p>0: OCP Hiccup mode (Level 0)</p> <p>1: OCP fail-safe PMIC turn-off (Level 1)</p>
[0]	<p>NVM_FS_OCP_BUCK1: BUCK1 OCP management mode selection.</p> <p>0: OCP Hiccup mode (Level 0)</p> <p>1: OCP fail-safe PMIC turn-off (Level 1)</p>

6.7.20 NVM fail-safe overcurrent protection shadow register 2 (NVM_FS_OCP_SHR2)

Table 98. NVM_FS_OCP_SHR2

7	6	5	4	3	2	1	0
-	-	-	NVM_FS_OCP_LDO5	NVM_FS_OCP_LDO4	NVM_FS_OCP_LDO3	NVM_FS_OCP_LDO2	-
R	R	R	R/W	R/W	R/W	R/W	R

- Address: 0xB0
- Default: Depends on the PMIC part number
- Description: NVM fail-safe overcurrent protection shadow register 2 (see Section 5.4.6.1: Turn-OFF condition triggered by software switch-off).

[7]	reserved
[4]	<p>NVM_FS_OCP_LDO5: LDO5 OCP management mode selection.</p> <p>0: OCP Hiccup mode (Level 0) 1: OCP fail-safe PMIC turn-off (Level 1)</p>
[3]	<p>NVM_FS_OCP_LDO4: LDO4 OCP management mode selection.</p> <p>0: OCP Hiccup mode (Level 0) 1: OCP fail-safe PMIC turn-off (Level 1)</p>
[2]	<p>NVM_FS_OCP_LDO3: LDO3 OCP management mode selection.</p> <p>0: OCP Hiccup mode (Level 0) 1: OCP fail-safe PMIC turn-off (Level 1)</p>
[1]	<p>NVM_FS_OCP_LDO2: LDO2 OCP management mode selection.</p> <p>0: OCP Hiccup mode (Level 0) 1: OCP fail-safe PMIC turn-off (Level 1)</p>
[0]	reserved

6.7.21 NVM fail-safe shadow register 1 (NVM_FS_SHR1)

Table 99. NVM_FS_SHR1

7	6	5	4	3	2	1	0
VIN_FLT_CNT_MAX[3:0]				PKEY_FLT_CNT_MAX[3:0]			
R/W	R/W	R/W	R/W	R/W	R/W	R/W	R/W

- Address: 0xB1
- Default: Depends on the PMIC part number
- Description: NVM fail-safe shadow register 1 (see Section 5.4.5).

[7:4]	<p>VIN_FLT_CNT_MAX[3:0]: setting of the maximum number of occurrences triggered by a VIN falling below VINOK_Fall hard-fault source.</p> <p>0000: 0 hard-faults allowed (PMIC goes in FAIL_SAFE_LOCK_STATE when the 1st hard-fault condition occurs)</p> <p>0001: 1 hard-fault allowed (the PMIC goes in FAIL_SAFE_LOCK_STATE when the 2nd hard-fault condition occurs)</p> <p>...</p> <p>1110: 14 hard-faults allowed (the PMIC goes in FAIL_SAFE_LOCK_STATE when the 15th hard-fault condition occurs)</p> <p>1111: ∞ hard-faults allowed (fail-safe disabled: the PMIC always restarts when the hard-fault condition occurs)</p>
[3:0]	<p>PKEY_FLT_CNT_MAX[3:0]: setting of the maximum number of occurrences triggered by a PONKEYn long key press hard-fault source.</p> <p>0000: 0 hard-faults allowed (the PMIC goes in FAIL_SAFE_LOCK_STATE when the 1st hard-fault condition occurs)</p> <p>0001: 1 hard-fault allowed (the PMIC goes in FAIL_SAFE_LOCK_STATE when the 2nd hard-fault condition occurs)</p> <p>...</p> <p>1110: 1 hard-faults allowed (the PMIC goes into FAIL_SAFE_LOCK_STATE when the 15th hard-fault condition occurs)</p> <p>1111: ∞ hard-faults allowed (fail-safe disabled: the PMIC always restarts when a hard-fault condition occurs)</p>

6.7.22 NVM fail-safe shadow register 2 (NVM_FS_SHR2)

Table 100. NVM_FS_SHR2

7	6	5	4	3	2	1	0
TSHDN_FLT_CNT_MAX[3:0]				OCP_FLT_CNT_MAX[3:0]			
R/W	R/W	R/W	R/W	R/W	R/W	R/W	R/W

- Address: 0xB2
- Default: Depends on the PMIC part number
- Description: NVM fail-safe shadow register 2 (see Section 5.4.5).

[7:4]	<p>TSHDN_FLT_CNT_MAX[3:0]: setting of the maximum number of occurrences triggered by a thermal shutdown hard-fault source.</p> <p>0000: 0 hard-faults allowed (the PMIC goes in FAIL_SAFE_LOCK_STATE when the 1st hard-fault condition occurs)</p> <p>0001: 1 hard-fault allowed (the PMIC goes in FAIL_SAFE_LOCK_STATE when the 2nd hard-fault condition occurs)</p> <p>...</p> <p>1110: 14 hard-faults allowed (the PMIC goes in FAIL_SAFE_LOCK_STATE when the 15th hard-fault condition occurs)</p> <p>1111: ∞ hard-faults allowed (fail-safe disabled: the PMIC always restarts when a hard-fault condition occurs)</p>
[3:0]	<p>OCP_FLT_CNT_MAX[3:0]: setting of the maximum number of occurrences triggered by regulator overcurrent hard-fault source.</p> <p>0000: 0 hard-faults allowed (the PMIC goes in FAIL_SAFE_LOCK_STATE when the 1st hard-fault condition occurs)</p> <p>0001: 1 hard-fault allowed (the PMIC goes in FAIL_SAFE_LOCK_STATE when the 2nd hard-fault condition occurs)</p> <p>...</p> <p>1110: 14 hard-faults allowed (the PMIC goes in FAIL_SAFE_LOCK_STATE when the 15th hard-fault condition occurs)</p> <p>1111: ∞ hard-faults allowed (fail-safe disabled: the PMIC always restarts when a hard-fault condition occurs)</p>

6.7.23 NVM fail-safe shadow register 3 (NVM_FS_SHR3)

Table 101. NVM_FS_SHR3

7	6	5	4	3	2	1	0
-	FAIL_SAFE_LOCK_DIS	RST_FLT_CNT_TMR[1:0]		WDG_FLT_CNT_MAX[3:0]			
R	R/W	R/W	R/W	R/W	R/W	R/W	R/W

- Address: 0xB3
- Default: Depends on the PMIC part number
- Description: NVM fail-safe shadow register 3 (see Section 5.4.5).

[7]	reserved
[6]	<p>FAIL_SAFE_LOCK_DIS: disable fail-safe lock state (pass through)</p> <p>0: FAIL_SAFE_LOCK feature enabled (the PMIC stays in the FAIL_SAFE_LOCK state)</p> <p>1: FAIL_SAFE_LOCK feature disabled (the PMIC passes through the FAIL_SAFE_LOCK state to go into the OFF state)</p>
[5:4]	<p>RST_FLT_CNT_TMR [1:0]: reset fault counter timer settings. When the timer elapses, it automatically clears all fault counters (*_FLT_CNT)</p> <p>00: disabled</p> <p>01: 1 minute</p> <p>10: 6 minutes</p> <p>11: 60 minutes</p>
[3:0]	<p>WDG_FLT_CNT_MAX [3:0]: setting of the maximum number of occurrences triggered by a watchdog hard-fault source.</p> <p>0000: 0 hard-faults allowed (the PMIC goes into the FAIL_SAFE_LOCK_STATE when the 1st hard-fault condition occurs)</p> <p>0001: 1 hard-fault allowed (PMIC goes into the FAIL_SAFE_LOCK_STATE when the 2nd hard-fault condition occurs)</p> <p>...</p> <p>1110: 14 hard-faults allowed (the PMIC goes into the FAIL_SAFE_LOCK_STATE when the 15th hard-fault condition occurs)</p> <p>1111: ∞ hard-faults allowed (fail-safe disabled: the PMIC always restarts when a hard-fault condition occurs)</p>

6.7.24 NVM I²C device address shadow register (NVM_I²C_ADDR_SHR)

Table 102. NVM_I²C_ADDR_SHR

7	6	5	4	3	2	1	0
LOCK_NVM	I ² C_ADDR[6:0]						
R/W	R/W	R/W	R/W	R/W	R/W	R/W	R/W

- Address: 0xB5
- Default: Depends on the PMIC part number
- Description: NVM I²C device address shadow register.

The contents of this register take effect after the NVM programming command, then the NVM reloads (INIT&LOAD state or CHECK&LOAD state or NVM read command).

The LOCK_NVM bit takes effect on both shadow registers write and NVM programming command. A successful program operation is enough to have the lock active (without any reload).

[7]	LOCK_NVM: NVM write access lock: 0: NVM write allowed 1: NVM write disabled
[6:0]	I²C_ADDR [6:0]: I ² C device address.

6.7.25 NVM user free shadow register (NVM_USER_SHRx) (x = 1 to 2)

Table 103. NVM_USER_SHRx

7	6	5	4	3	2	1	0
NVM_USERx[7:0]							
R/W	R/W	R/W	R/W	R/W	R/W	R/W	R/W

- Address: 0xB6, 0xB7
- Default: 0x00 (genuine PMIC) or user defined value
- Description: User free shadow register 1 and 2.

Free usage scratch registers save end-product application data in the NVM. It requires an NVM programming command to save content in the NVM.

[7:0]	NVM_USERx [7:0]: user defined value
-------	--

6.7.26 NVM main control shadow register 4 (NVM_MAIN_CTL_SHR3)
Table 104. NVM_MAIN_CTRL_SHR4

7	6	5	4	3	2	1	0
VIN_DLY[1:0]		-		NVM_PKEY_EN_PULL[1:0]		EN_POL_CFG	PKEY_EN_CFG
R/W	R/W	R/W	R/W	R/W	R/W	R/W	R/W

- Address: 0xB9
- Default: 0x00 according to NVM
- Description: NVM Main control shadow register 3.

[7:6]	VIN_DLY [1:0]: V _{IN} additional delay 00: no delay (default) 01: 10 ms delay 10: 50 ms delay 11: 100 ms delay
[5:4]	reserved
[3:2]	NVM_PKEY_EN_PULL [1:0]: PONKEY _n /EN pad pull resistor selection. 00: no pull 01: pull-up active (R _{PU}) 10: pull-down active (R _{PD}) 11: no pull
[1]	EN_POL_CFG: EN Polarity Config 0: active high (default) 1: active low
[0]	PKEY_EN_CFG: PONKEY _n /EN feature enabled. 0: PONKEY functionality enabled (default) 1: EN functionality enable

7 Package information

To meet environmental requirements, ST offers these devices in different grades of **ECOPACK** packages, depending on their level of environmental compliance. ECOPACK specifications, grade definitions, and product status are available at: www.st.com. ECOPACK is an ST trademark.

9 Ordering information

Table 106. Ordering information

Order code	Part number	Marking	VIO (LDO2) programming option	Packing
STPMIC1LAPQR	STPMIC1LA	PM1LA	3.3 V	VFQFPN 28L (4.0x4.0x1.0)
STPMIC1LBPQR	STPMIC1LB	PM1LB	1.8 V	
STPMIC1LDPQR	STPMIC1LD	PM1LD	3.3 V	

Revision history

Table 107. Document revision history

Date	Version	Changes
26-Sep-2025	1	First release.
24-Oct-2025	2	Minor text changes.
22-Jan-2026	3	Updated Section 5.5.1
28-Apr-2026	4	Updated Section Description

Contents

1	Device configuration table	2
2	Typical application schematic	3
2.1	Recommended external components	4
2.2	Pin out and pin description	5
3	Electrical and timing characteristics	7
3.1	Absolute maximum ratings	7
3.2	Thermal characteristics	7
3.3	Consumption in typical application scenarios	8
3.4	Electrical and timing parameter specifications	9
3.4.1	General section	9
3.4.2	Digital interface	11
3.4.3	LDO2 and LDO5	12
3.4.4	LDO3	13
3.4.5	LDO4	14
3.4.6	BUCK1	15
3.4.7	BUCK2	16
4	Power regulator descriptions	19
4.1	Overview	19
4.2	LDO regulators	19
4.2.1	LDO Common features	20
4.2.2	LDO3 special features	21
4.2.3	LDO4 special features	21
4.2.4	LDO output voltage settings	21
4.2.5	Examples of DDR memory power supply topology using LDOs	22
4.3	Buck converters	23
4.3.1	Buck converters common features	23
4.3.2	Buck output voltage settings	26
5	Feature descriptions	27
5.1	Functional state machine	27
5.1.1	Transition conditions	29
5.1.2	State explanations	30
5.2	POWER_UP / POWER_DOWN sequence	32
5.2.1	NO_SUPPLY and INIT&LOAD:	33
5.2.2	OFF and CHECK&LOAD:	33
5.2.3	POWER_UP:	33

5.2.4	POWER_ON:	33
5.2.5	POWER_DOWN:	33
5.3	Digital pin description	34
5.3.1	PONKEYn/EN	34
5.3.2	RSTn	35
5.3.3	INTn	35
5.3.4	PWRCTRL1, PWRCTRL2	35
5.3.5	GPO1, GPO2	35
5.4	Feature descriptions	36
5.4.1	V _{IN} monitoring	36
5.4.2	V _{INPOR}	36
5.4.3	V _{INOK}	36
5.4.4	V _{INLOW}	37
5.4.5	Turn-on conditions	37
5.4.6	Turn-off conditions	38
5.4.7	Fail-safe management	39
5.4.8	Hard-fault counters reset and auto-reset	40
5.4.9	FAIL_SAFE_LOCK state skipping	40
5.4.10	Power control management (PWRCTRLx)	41
5.4.11	PWRCTRL delay high and delay low behaviors	43
5.4.12	Regulator-independent reset detailed behaviors (PWRCTRL_RST)	44
5.4.13	Reset management (RSTn) and mask_reset software option	45
5.4.14	Thermal protection	46
5.4.15	Overcurrent (OCP) and Hiccup mode	47
5.4.16	Level 0: Independent regulator OCP Hiccup mode management	47
5.4.17	Level 1: PMIC OCP fail-safe management	48
5.4.18	Watchdog management	49
5.5	Programming	49
5.5.1	I ² C interface	49
5.5.2	Non-volatile memory (NVM)	50
6	Register descriptions	53
6.1	Register map	53
6.2	Status registers	59
6.2.1	Product ID status register (PRODUCT_ID_SR)	59
6.2.2	Version status register (VERSION_SR)	59
6.2.3	Turn-on status register (TURN_ON_SR)	60
6.2.4	Turn-off status register (TURN_OFF_SR)	61

6.2.5	Restart status register (RESTART_SR)	62
6.2.6	Overcurrent protection status register 1 (OCP_SR1)	63
6.2.7	Overcurrent protection status register 2 (OCP_SR2)	64
6.2.8	Enable status register 1 (EN_SR1)	65
6.2.9	Enable status register 2 (EN_SR2)	65
6.2.10	Fail-safe counter status register 1 (FS_CNT_SR1)	66
6.2.11	Fail-safe counter status register 2 (FS_CNT_SR2)	66
6.2.12	Fail-safe counter status register 3 (FS_CNT_SR3)	67
6.2.13	Mode status register (MODE_SR)	67
6.2.14	GPO status register (GPO_SR)	68
6.3	Control registers	69
6.3.1	Main control register (MAIN_CR)	69
6.3.2	VINLOW monitoring control register (VINLOW_CR)	70
6.3.3	PONKEYn long key press control register (PKEY_LKP_CR)	71
6.3.4	Watchdog control register (WDG_CR)	72
6.3.5	Watchdog timer control register (WDG_TMR_CR)	72
6.3.6	Watchdog timer status register (WDG_TMR_SR)	73
6.3.7	Fail-safe overcurrent protection control register 1 (FS_OCP_CR1)	73
6.3.8	Fail-safe overcurrent protection control register 2 (FS_OCP_CR2)	74
6.3.9	Pads pull control register (PADS_PULL_CR)	75
6.3.10	Buck pull-down control register 1 (BUCKS_PD_CR)	76
6.3.11	LDO pull-down control register (LDOS_PD_CR)	77
6.3.12	Mask reset GPO control register (GPO_MRST_CR)	78
6.3.13	Mask reset buck control register (BUCKS_MRST_CR)	79
6.3.14	Mask reset LDO control register (LDOS_MRST_CR)	80
6.4	Power supply control registers	81
6.4.1	BUCKx MAIN mode control register 1 (BUCKx_MAIN_CR1) (x = 1 to 2)	81
6.4.2	BUCKx MAIN mode control register 2 (BUCKx_MAIN_CR2) (x = 1 to 2)	81
6.4.3	BUCKx ALTERNATE mode control register 1 (BUCKx_ALT_CR1) (x = 1 to 2)	82
6.4.4	BUCKx ALTERNATE mode control register 2 (BUCKx_ALT_CR2) (x = 1 to 2)	82
6.4.5	BUCKx PWRCTRL control register (BUCKx_PWRCTRL_CR) (x = 1 to 2)	83
6.4.6	GPOx MAIN mode control register (GPOx_MAIN_CR) (x = 1, 2)	84
6.4.7	GPOx ALTERNATE mode control register (GPOx_ALT_CR) (x = 1, 2)	84
6.4.8	GPOx PWRCTRL control register (GPOx_PWRCTRL_CR) (x = 1, 2)	85
6.4.9	LDOx MAIN mode control register (LDOx_MAIN_CR) (x = 2/5)	86
6.4.10	LDOx ALTERNATE mode control register (LDOx_ALT_CR) (x = 2/5)	86
6.4.11	LDOx PWRCTRL control register (LDOx_PWRCTRL_CR) (x = 2 to 5)	87
6.4.12	LDO3 MAIN mode control register (LDO3_MAIN_CR)	88

6.4.13	LDO3 ALTERNATE mode control register (LDO3_ALT_CR)	89
6.4.14	LDO4 MAIN mode control register (LDO4_MAIN_CR)	89
6.4.15	LDO4 ALTERNATE mode control register (LDO4_ALT_CR)	90
6.5	Interrupt registers	91
6.5.1	Interrupt management overview	91
6.5.2	Interrupt pending register 1 (INT_PENDING_R1)	91
6.5.3	Interrupt pending register 2 (INT_PENDING_R2)	92
6.5.4	Interrupt pending register 3 (INT_PENDING_R3)	92
6.5.5	Interrupt pending register 4 (INT_PENDING_R4)	93
6.5.6	Interrupt clear registers (INT_CLEAR_Rx) (x = 1 to 4)	93
6.5.7	Interrupt mask registers (INT_MASK_Rx) (x = 1 to 4)	94
6.5.8	Interrupt source registers (INT_SRC_Rx) (x = 1 to 4)	94
6.5.9	Interrupt debug latch registers (INT_DBG_LATCH_Rx) (x = 1 to 4)	94
6.6	NVM registers	95
6.6.1	NVM status register (NVM_SR)	95
6.6.2	NVM control register (NVM_CR)	95
6.7	NVM shadow registers	96
6.7.1	NVM main control shadow register 1 (NVM_MAIN_CTRL_SHR1)	96
6.7.2	NVM main control shadow register 2 (NVM_MAIN_CTRL_SHR2)	97
6.7.3	NVM rank shadow register 1 (NVM_RANK_SHR1)	98
6.7.4	NVM rank shadow register 5 (NVM_RANK_SHR5)	99
6.7.5	NVM rank shadow register 6 (NVM_RANK_SHR6)	99
6.7.6	NVM rank shadow register 7 (NVM_RANK_SHR7)	99
6.7.7	NVM BUCK mode shadow register 1 (NVM_BUCK_MODE_SHR1)	100
6.7.8	NVM BUCK1 output voltage shadow register (NVM_BUCK1_VOUT_SHR)	100
6.7.9	NVM BUCK2 output voltage shadow register (NVM_BUCK2_VOUT_SHR)	101
6.7.10	GPO Config shadow register (NVM_MAIN_CTRL_SHR3)	101
6.7.11	GPO Rank shadow register 1 (NVM_RANK_SHR9)	102
6.7.12	NVM LDOx shadow register (NVM_LDOx_SHR) (x = 2/5)	103
6.7.13	NVM LDO3 control shadow register (NVM_LDO3_SHR)	103
6.7.14	NVM pull-down control shadow register 1 (NVM_PD_SHR1)	104
6.7.15	NVM pull-down control shadow register 3 (NVM_PD_SHR3)	105
6.7.16	NVM BUCKs output current limitation shadow register 1 (NVM_BUCKS_IOUT_SHR1)	106
6.7.17	NVM BUCKs output current limitation shadow register 2 (NVM_BUCKS_IOUT_SHR2)	106
6.7.18	NVM LDOs output current limitation shadow register (NVM_LDOS_IOUT_SHR)	107
6.7.19	NVM fail-safe overcurrent protection shadow register 1 (NVM_FS_OCP_SHR1)	108
6.7.20	NVM fail-safe overcurrent protection shadow register 2 (NVM_FS_OCP_SHR2)	109
6.7.21	NVM fail-safe shadow register 1 (NVM_FS_SHR1)	110

6.7.22	NVM fail-safe shadow register 2 (NVM_FS_SHR2)	111
6.7.23	NVM fail-safe shadow register 3 (NVM_FS_SHR3)	112
6.7.24	NVM I ² C device address shadow register (NVM_I ² C_ADDR_SHR)	113
6.7.25	NVM user free shadow register (NVM_USER_SHRx) (x = 1 to 2)	113
6.7.26	NVM main control shadow register 4 (NVM_MAIN_CTL_SHR3)	114
7	Package information	115
8	VFQFPN 28L (4.0X4.0X1.0) package information	116
9	Ordering information	118
	Revision history	119

List of tables

Table 1.	Default configuration table	2
Table 2.	Passive components	4
Table 3.	Pin description	5
Table 4.	Absolute maximum ratings	7
Table 5.	Thermal characteristics	7
Table 6.	Consumption in typical application scenarios	8
Table 7.	Electrical and timing parameter specifications (general section)	9
Table 8.	Electrical and timing parameter specifications (digital interface)	11
Table 9.	Electrical and timing parameter specifications	12
Table 10.	Electrical and timing parameter specifications (LDO3)	13
Table 11.	Electrical and timing parameter specifications (LDO4)	14
Table 12.	Electrical and timing parameter specifications (BUCK1)	15
Table 13.	Electrical and timing parameter specifications	16
Table 14.	General description	19
Table 15.	LDO output voltage settings	21
Table 16.	Buck output voltage settings	26
Table 17.	PMIC state machine transition conditions	29
Table 18.	Turn-on conditions from external trigger source summary	37
Table 19.	Turn-off condition trigger sources	38
Table 20.	Hard-fault fail-safe counters and waits before restarting timer	39
Table 21.	Reset fault counter timer settings	40
Table 22.	PWRCTRLx polarity truth table	41
Table 23.	Regulator control truth table	42
Table 24.	Slave address format	50
Table 25.	Register address format	50
Table 26.	Register data format	50
Table 27.	PRODUCT_ID_SR	59
Table 28.	. VERSION_SR	59
Table 29.	TURN_ON_SR	60
Table 30.	TURN_OFF_SR	61
Table 31.	RESTART_SR	62
Table 32.	Overcurrent protection status register 1 (OCP_SR1)	63
Table 33.	Overcurrent protection status register 2 (OCP_SR2)	64
Table 34.	EN_SR1	65
Table 35.	EN_SR2	65
Table 36.	FS_CNT_SR1	66
Table 37.	FS_CNT_SR2	66
Table 38.	FS_CNT_SR3	67
Table 39.	MODE_SR	67
Table 40.	GPO_SR	68
Table 41.	MAIN_CR	69
Table 42.	VINLOW_CR	70
Table 43.	PKEY_LKP_CR	71
Table 44.	WDG_CR	72
Table 45.	WDG_TMR_CR	72
Table 46.	WDG_TMR_SR	73
Table 47.	FS_OCP_CR1	73
Table 48.	FS_OCP_CR2	74
Table 49.	PADS_PULL_CR	75
Table 50.	. BUCKS_PD_CR	76
Table 51.	LDOS_PD_CR	77
Table 52.	GPO_MRST_CR	78
Table 53.	BUCKS_MRST_CR	79

Table 54.	LDOS_MRST_CR	80
Table 55.	BUCKx_MAIN_CR1	81
Table 56.	BUCKx_MAIN_CR2	81
Table 57.	BUCKx_ALT_CR1	82
Table 58.	BUCKx_ALT_CR2	82
Table 59.	BUCKx_PWRCTRL_CR	83
Table 60.	GPOx_MAIN_CR	84
Table 61.	GPOx_ALT_CR	84
Table 62.	GPOx_PWRCTRL_CR	85
Table 63.	LDOx_MAIN_CR	86
Table 64.	LDOx_ALT_CR	86
Table 65.	LDOx_PWRCTRL_CR	87
Table 66.	LDO3_MAIN_CR	88
Table 67.	LDO3_ALT_CR	89
Table 68.	LDO4_MAIN_CR	89
Table 69.	LDO4_ALT_CR	90
Table 70.	INT_PENDING_R1	91
Table 71.	INT_PENDING_R2	92
Table 72.	INT_PENDING_R3	92
Table 73.	INT_PENDING_R4	93
Table 74.	INT_CLEAR_Rx	93
Table 75.	INT_MASK_Rx	94
Table 76.	INT_DBG_LATCH_Rx	94
Table 77.	NVM_SR	95
Table 78.	NVM_CR	95
Table 79.	NVM_MAIN_CTRL_SHR1	96
Table 80.	NVM_MAIN_CTRL_SHR2	97
Table 81.	NVM_RANK_SHR1	98
Table 82.	NVM_RANK_SHR5	99
Table 83.	NVM_RANK_SHR6	99
Table 84.	NVM_RANK_SHR7	99
Table 85.	NVM_BUCK_MODE_SHR1	100
Table 86.	NVM_BUCK1_VOUT_SHR	100
Table 87.	NVM_BUCK2_VOUT_SHR	101
Table 88.	NVM_MAIN_CTRL_SHR3	101
Table 89.	NVM_RANK_SHR9	102
Table 90.	NVM_LDOx_SHR	103
Table 91.	NVM_LDO3_SHR	103
Table 92.	NVM_PD_SHR1	104
Table 93.	NVM_PD_SHR3	105
Table 94.	NVM_BUCKS_IOUT_SHR1	106
Table 95.	NVM_BUCKS_IOUT_SHR2	106
Table 96.	NVM_LDOS_IOUT_SHR	107
Table 97.	NVM_FS_OCP_SHR1	108
Table 98.	NVM_FS_OCP_SHR2	109
Table 99.	NVM_FS_SHR1	110
Table 100.	NVM_FS_SHR2	111
Table 101.	NVM_FS_SHR3	112
Table 102.	NVM_I ² C_ADD_SHR	113
Table 103.	NVM_USER_SHRx	113
Table 104.	NVM_MAIN_CTRL_SHR4	114
Table 105.	VFQFPN 28L (4.0X4.0X1.0) mechanical data	117
Table 106.	Ordering information.	118
Table 107.	Document revision history	119

List of figures

Figure 1.	Typical application schematic	3
Figure 2.	Pin configuration VFQFPN 28L top view	5
Figure 3.	LDO startup/shutdown timings	20
Figure 4.	LDO3 uses in sink/source mode with DDR3L	22
Figure 5.	LDO3 uses in LDO mode with IpDDR3.	22
Figure 6.	Buck dynamic voltage scaling (DVS)	24
Figure 7.	Buck startup/shutdown timings	25
Figure 8.	PMIC state machine	28
Figure 9.	PMIC POWER_UP and POWER_DOWN sequence example	32
Figure 10.	PONKEYn debounce filter behavior.	34
Figure 11.	V _{IN} monitoring thresholds.	36
Figure 12.	PWRCTRLx logic circuitry principle	41
Figure 13.	Delay rising and delay falling behaviors example.	44
Figure 14.	Regulator-independent reset behavior example	45
Figure 15.	Reset power-cycle sequence example.	46
Figure 16.	Thermal protection thresholds	47
Figure 17.	I ² C read operation.	50
Figure 18.	I ² C write operation.	50
Figure 19.	VFQFPN (4.0X4.0.X1.0) package outline116
Figure 20.	Suggested footprint.117

IMPORTANT NOTICE – READ CAREFULLY

STMicroelectronics NV and its subsidiaries (“ST”) reserve the right to make changes, corrections, enhancements, modifications, and improvements to ST products and/or to this document at any time without notice.

In the event of any conflict between the provisions of this document and the provisions of any contractual arrangement in force between the purchasers and ST, the provisions of such contractual arrangement shall prevail.

The purchasers should obtain the latest relevant information on ST products before placing orders. ST products are sold pursuant to ST’s terms and conditions of sale in place at the time of order acknowledgment.

The purchasers are solely responsible for the choice, selection, and use of ST products and ST assumes no liability for application assistance or the design of the purchasers’ products.

No license, express or implied, to any intellectual property right is granted by ST herein.

Resale of ST products with provisions different from the information set forth herein shall void any warranty granted by ST for such product.

If the purchasers identify an ST product that meets their functional and performance requirements but that is not designated for the purchasers’ market segment, the purchasers shall contact ST for more information.

ST and the ST logo are trademarks of ST. For additional information about ST trademarks, refer to www.st.com/trademarks. All other product or service names are the property of their respective owners.

Information in this document supersedes and replaces information previously supplied in any prior versions of this document.

© 2026 STMicroelectronics – All rights reserved