

# POWER-LOCK FASTENER N 45

Article Nr. 21.0918/0

[See the product on the website](#) →

[Download CAD Files](#) →

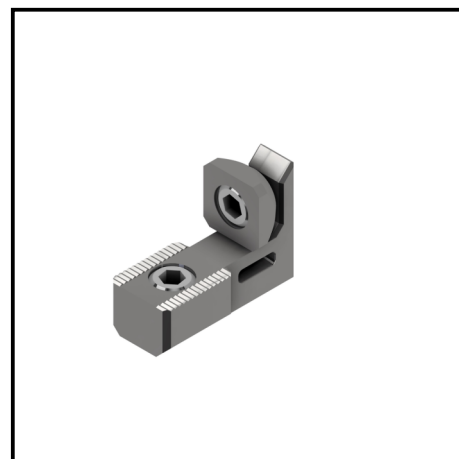
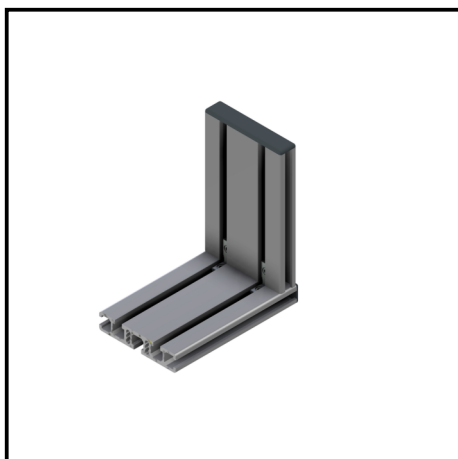
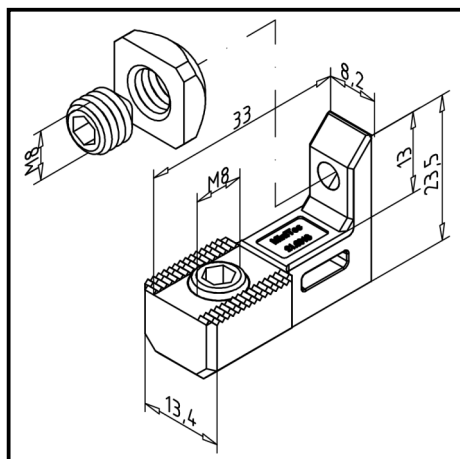

## TECHN. DATA / ITEMS SUPPLIED

- Steel, galvanized
- Connection element with pre-assembled threaded pin M8
- 1 Slide nut M8 with pre-assembled setscrew
- Weight = 0.036 kg/piece

## APPLICATIONS

- For connecting all profiles of the profile series 45
- Especially for post-mounting of additional profiles in existing constructions
- For profile sections bigger than 45 x 45 several fasteners can be used

## ASSEMBLY

- Position the profile with the connector
- Swing in and tighten sliding nut with threaded pin
- Tighten set screw of fastener
- Tighten both threaded pins with SW 4 and with 10 Nm torque

# POWER-LOCK FASTENER N 45

Article Nr. 21.0918/0

[See the product on the website →](#)

[Download CAD Files →](#)

