

# RYZ014A Evaluation Kit RYZ014AAA

## User's Manual

All information contained in these materials, including products and product specifications, represents information on the product at the time of publication and is subject to change by Renesas Electronics Corp. without notice. Please review the latest information published by Renesas Electronics Corp. through various means, including the Renesas Electronics Corp. website (<http://www.renesas.com>).

## Notice

1. Descriptions of circuits, software and other related information in this document are provided only to illustrate the operation of semiconductor products and application examples. You are fully responsible for the incorporation or any other use of the circuits, software, and information in the design of your product or system. Renesas Electronics disclaims any and all liability for any losses and damages incurred by you or third parties arising from the use of these circuits, software, or information.
  2. Renesas Electronics hereby expressly disclaims any warranties against and liability for infringement or any other claims involving patents, copyrights, or other intellectual property rights of third parties, by or arising from the use of Renesas Electronics products or technical information described in this document, including but not limited to, the product data, drawings, charts, programs, algorithms, and application examples.
  3. No license, express, implied or otherwise, is granted hereby under any patents, copyrights or other intellectual property rights of Renesas Electronics or others.
  4. You shall not alter, modify, copy, or reverse engineer any Renesas Electronics product, whether in whole or in part. Renesas Electronics disclaims any and all liability for any losses or damages incurred by you or third parties arising from such alteration, modification, copying or reverse engineering.
  5. Renesas Electronics products are classified according to the following two quality grades: "Standard" and "High Quality". The intended applications for each Renesas Electronics product depends on the product's quality grade, as indicated below.
    - "Standard": Computers; office equipment; communications equipment; test and measurement equipment; audio and visual equipment; home electronic appliances; machine tools; personal electronic equipment; industrial robots; etc.
    - "High Quality": Transportation equipment (automobiles, trains, ships, etc.); traffic control (traffic lights); large-scale communication equipment; key financial terminal systems; safety control equipment; etc.
- Unless expressly designated as a high reliability product or a product for harsh environments in a Renesas Electronics data sheet or other Renesas Electronics document, Renesas Electronics products are not intended or authorized for use in products or systems that may pose a direct threat to human life or bodily injury (artificial life support devices or systems; surgical implantations; etc.), or may cause serious property damage (space system; undersea repeaters; nuclear power control systems; aircraft control systems; key plant systems; military equipment; etc.). Renesas Electronics disclaims any and all liability for any damages or losses incurred by you or any third parties arising from the use of any Renesas Electronics product that is inconsistent with any Renesas Electronics data sheet, user's manual or other Renesas Electronics document.
6. When using Renesas Electronics products, refer to the latest product information (data sheets, user's manuals, application notes, "General Notes for Handling and Using Semiconductor Devices" in the reliability handbook, etc.), and ensure that usage conditions are within the ranges specified by Renesas Electronics with respect to maximum ratings, operating power supply voltage range, heat dissipation characteristics, installation, etc. Renesas Electronics disclaims any and all liability for any malfunctions, failure or accident arising out of the use of Renesas Electronics products outside of such specified ranges.
  7. Although Renesas Electronics endeavors to improve the quality and reliability of Renesas Electronics products, semiconductor products have specific characteristics, such as the occurrence of failure at a certain rate and malfunctions under certain use conditions. Unless designated as a high reliability product or a product for harsh environments in a Renesas Electronics data sheet or other Renesas Electronics document, Renesas Electronics products are not subject to radiation resistance design. You are responsible for implementing safety measures to guard against the possibility of bodily injury, injury or damage caused by fire, and/or danger to the public in the event of a failure or malfunction of Renesas Electronics products, such as safety design for hardware and software, including but not limited to redundancy, fire control and malfunction prevention, appropriate treatment for aging degradation or any other appropriate measures. Because the evaluation of microcomputer software alone is very difficult and impractical, you are responsible for evaluating the safety of the final products or systems manufactured by you.
  8. Please contact a Renesas Electronics sales office for details as to environmental matters such as the environmental compatibility of each Renesas Electronics product. You are responsible for carefully and sufficiently investigating applicable laws and regulations that regulate the inclusion or use of controlled substances, including without limitation, the EU RoHS Directive, and using Renesas Electronics products in compliance with all these applicable laws and regulations. Renesas Electronics disclaims any and all liability for damages or losses occurring as a result of your noncompliance with applicable laws and regulations.
  9. Renesas Electronics products and technologies shall not be used for or incorporated into any products or systems whose manufacture, use, or sale is prohibited under any applicable domestic or foreign laws or regulations. You shall comply with any applicable export control laws and regulations promulgated and administered by the governments of any countries asserting jurisdiction over the parties or transactions.
  10. It is the responsibility of the buyer or distributor of Renesas Electronics products, or any other party who distributes, disposes of, or otherwise sells or transfers the product to a third party, to notify such third party in advance of the contents and conditions set forth in this document.
  11. This document shall not be reprinted, reproduced or duplicated in any form, in whole or in part, without prior written consent of Renesas Electronics.
  12. Please contact a Renesas Electronics sales office if you have any questions regarding the information contained in this document or Renesas Electronics products.

(Note1) "Renesas Electronics" as used in this document means Renesas Electronics Corporation and also includes its directly or indirectly controlled subsidiaries.

(Note2) "Renesas Electronics product(s)" means any product developed or manufactured by or for Renesas Electronics.

(Rev.4.0-1 November 2017)

## Corporate Headquarters

TOYOSU FORESIA, 3-2-24 Toyosu,  
Koto-ku, Tokyo 135-0061, Japan  
[www.renesas.com](http://www.renesas.com)

## Trademarks

Renesas and the Renesas logo are trademarks of Renesas Electronics Corporation. All trademarks and registered trademarks are the property of their respective owners.

## Contact information

For further information on a product, technology, the most up-to-date version of a document, or your nearest sales office, please visit:  
[www.renesas.com/contact/](http://www.renesas.com/contact/).

## Renesas RYZ014AAA Disclaimer

By using this RYZ014AAA, the user accepts the following terms, which are in addition to, and control in the event of disagreement, with Renesas' General Terms and Conditions available at <https://www.renesas.com/en-us/legal/disclaimer.html>.

The RYZ014AAA is not guaranteed to be error free, and the entire risk as to the results and performance of the RYZ014AAA is assumed by the User. The RYZ014AAA is provided by Renesas on an "as is" basis without warranty of any kind whether express or implied, including but not limited to the implied warranties of satisfactory quality, fitness for a particular purpose, title, and non-infringement of intellectual property rights with regard to the RYZ014AAA. Renesas expressly disclaims all such warranties.

Renesas does not consider the RYZ014AAA a finished product and therefore the RYZ014AAA may not yet comply with some requirements applicable to finished products, including, but not limited to recycling (WEEE), CE, UL, restricted substances (ROHS), FCC, FEE, and electromagnetic compatibility regulations. Renesas or its affiliates shall in no event be liable for any loss of profit, loss of data, loss of contract, loss of business, damage to reputation or goodwill, any economic loss, any reprogramming or recall costs (whether the foregoing losses are direct or indirect) nor shall Renesas or its affiliates be liable for any other direct or indirect special, incidental or consequential damages arising out of or in relation to the use of this RYZ014AAA, even if Renesas or its affiliates have been advised of the possibility of such damages.

Renesas has used reasonable care in preparing the information included in this document, but Renesas does not warrant that such information is error free nor does Renesas guarantee an exact match for every application or parameter to part numbers designated by other vendors listed herein. The information provided in this document is intended solely to enable the use of Renesas products. No express or implied license to any intellectual property right is granted by this document or in connection with the sale of Renesas products. Renesas reserves the right to make changes to specifications and product descriptions at any time without notice. Renesas assumes no liability for any damages incurred by you resulting from errors in or omissions from the information included herein. Renesas cannot verify, and assumes no liability for, the accuracy of information available on another company's website.

## Precautions

This Renesas Synergy™ Development Kit is only intended for use in a laboratory environment under ambient temperature and humidity conditions. A safe separation distance should be used between this and any sensitive equipment. Its use outside the laboratory, classroom, study area, or similar such area invalidates conformity with the protection requirements of the Electromagnetic Compatibility Directive and could lead to prosecution.

The product generates, uses, and can radiate radio frequency energy and may cause harmful interference to radio communications. There is no guarantee that interference will not occur in a particular installation. If this equipment causes harmful interference to radio or television reception, which can be determined by turning the equipment off or on, you are encouraged to try to correct the interference by one or more of the following measures:

- Ensure attached cables do not lie across the equipment.
- Reorient the receiving antenna.
- Increase the distance between the equipment and the receiver.
- Connect the equipment into an outlet on a circuit different from that which the receiver is connected.
- Power down the equipment when not in use.
- Consult the dealer or an experienced radio/TV technician for help.

Note: It is recommended that wherever possible shielded interface cables are used.

The product is potentially susceptible to certain EMC phenomena. To mitigate against them it is recommended that the following measures be undertaken:

- The user is advised that mobile phones should not be used within 10 m of the product when in use.
- The user is advised to take ESD precautions when handling the equipment.

The Renesas Synergy™ Development Kit does not represent an ideal reference design for an end product and does not fulfill the regulatory standards for an end product.

RYZ014AAA

## RYZ014A Evaluation Kit

### Contents

1.	Getting Started .....	2
1.1	Evaluation Kit Contents .....	2
1.2	Prepare RYZ014AAA Evaluation Kit .....	3
1.3	Install the Drivers .....	7
1.4	Set the COM Ports .....	8
1.5	Activate the SIM Card .....	9
1.6	Configure Supported Operators .....	18
1.7	Connect to LTE Network .....	18
2.	Hardware Description .....	19
2.1	Overview .....	19
2.2	Power Supplies .....	21
2.3	Power-On and Reset .....	21
2.4	USB Port and UART Switches .....	21
2.5	SIM Card .....	22
2.6	LEDs .....	23
2.7	User Button and Switch .....	23
2.8	Expansion Connectors .....	23
2.9	LTE Antenna and RF Connectors .....	26
2.10	Default Position for Jumpers and Switches .....	26
3.	Advanced Functions .....	27
3.1	How to Connect an External Power Supply .....	27
3.1.1	Power via VBAT_IN on J4 Connector .....	27
3.1.2	Power via VBAT_CORE on ST3 Connector .....	27
3.2	How to Connect a Series Current Meter .....	27
3.3	How to Perform a Remote Reset .....	27
3.4	How to Modify the Board by Soldering Bridges .....	28
4.	Certification of Compliance .....	30
5.	Appendix: Glossary and Abbreviations .....	30
6.	About this Manual .....	31
6.1	Purpose and Scope .....	31
6.2	Who Should Read this Document .....	31
6.3	Changes in this Document .....	31
6.4	References .....	31
6.5	Documentation Conventions .....	31
	Revision History .....	33

# 1. Getting Started

## 1.1 Evaluation Kit Contents

The contents of the Evaluation Kit are:

- One RYZ014AAA board
- One Raspberry Pi Zero W
- One Micro USB to USB cable
- One Micro USB to USB converter
- One power cable
- One HDMI mini to HDMI adapter
- One SIM Card – Micro SD

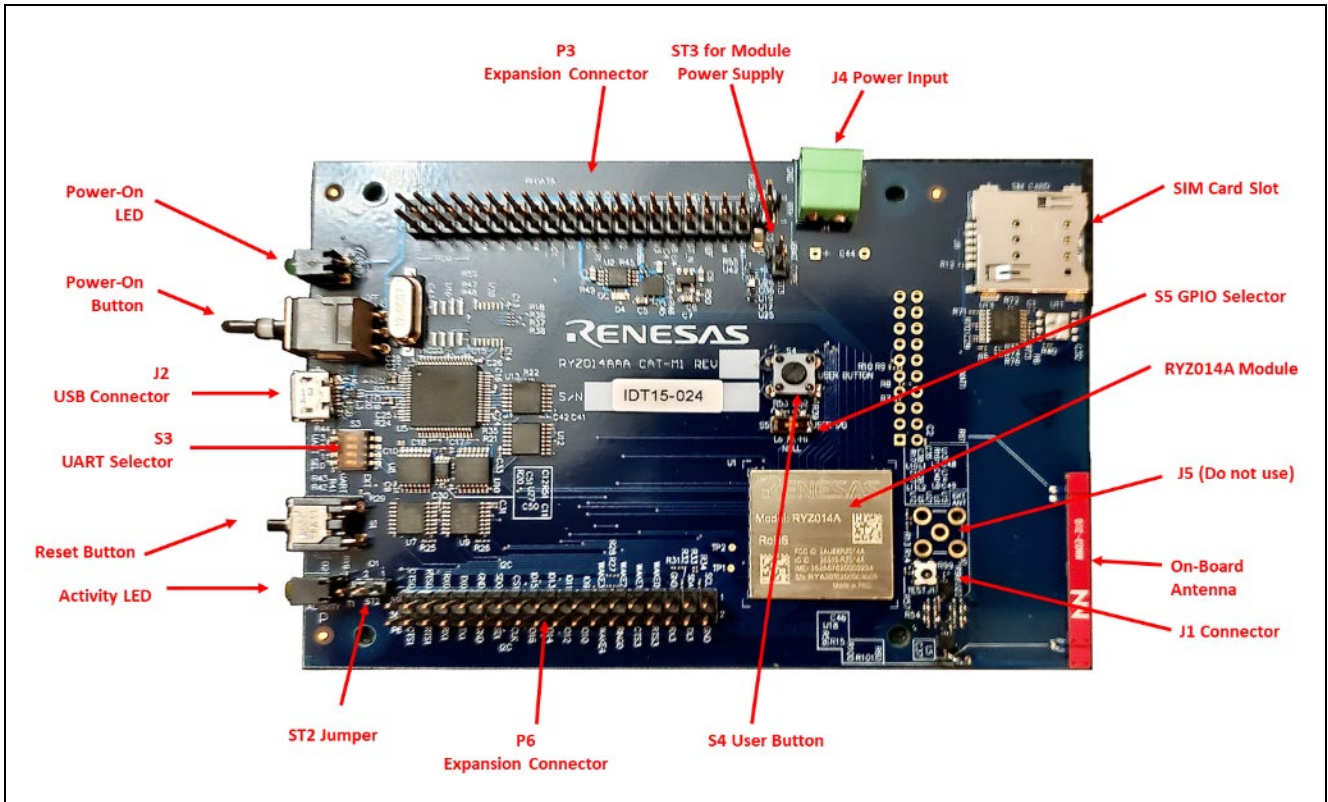

Figure 1. RYZ014AAA Board

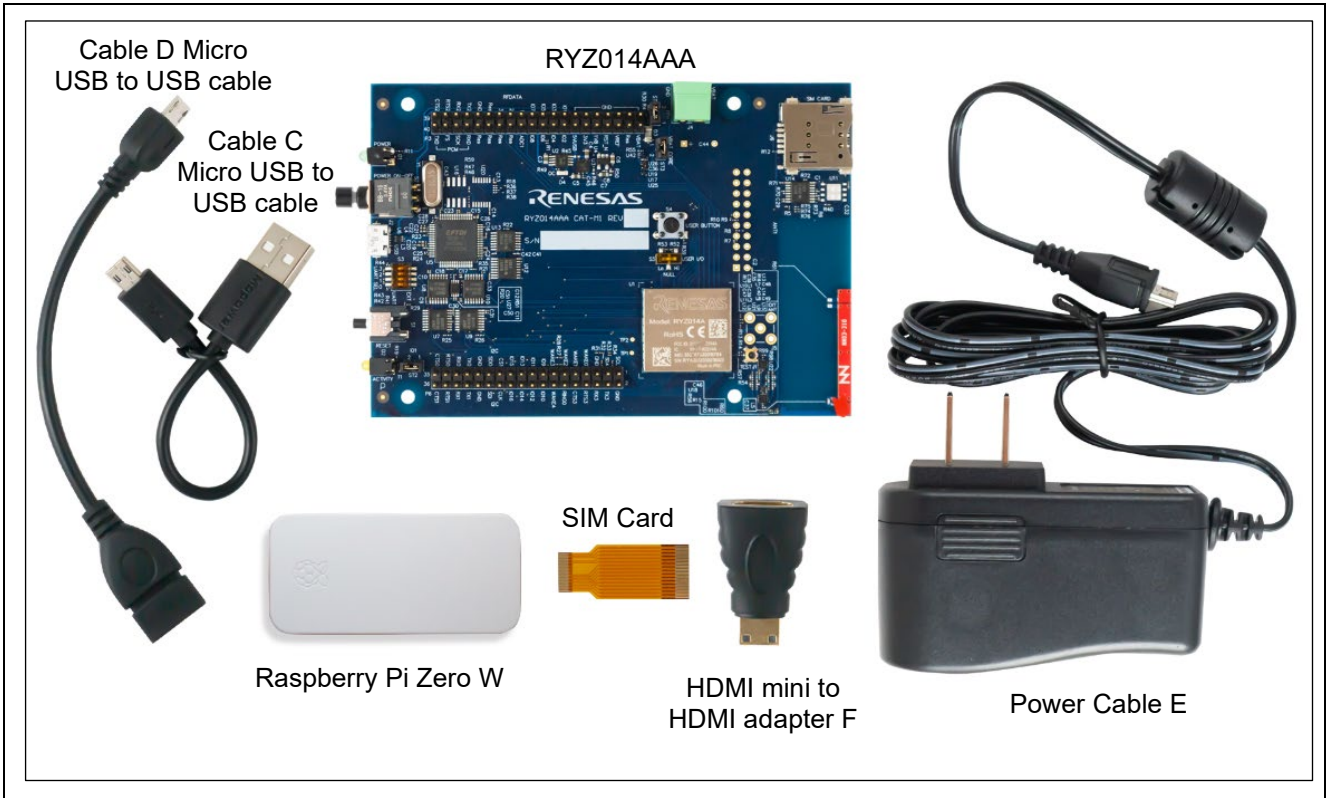

Figure 2. RYZ014AAA Kit Contents

### 1.2 Prepare RYZ014AAA Evaluation Kit

1. Plug cable C into port A1

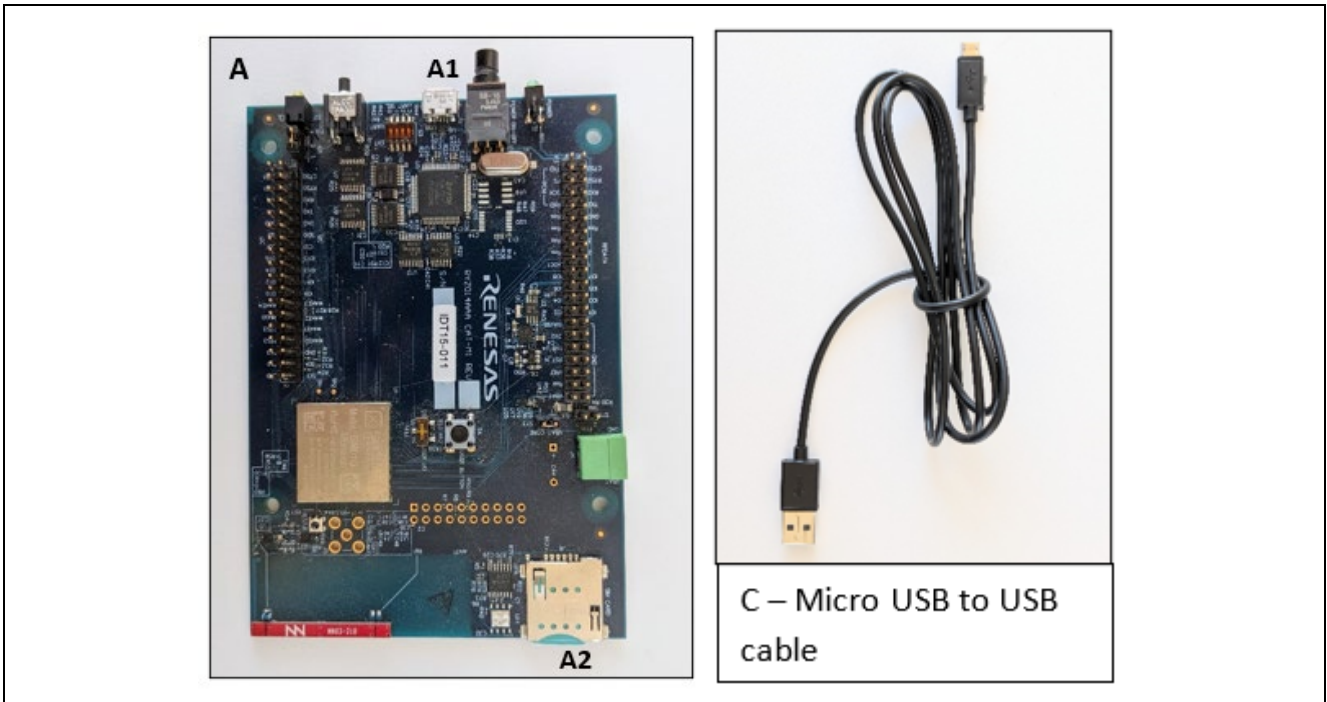

Figure 3. Cable C to Port A1

2. Plug cable C (USB) into converter D (USB)

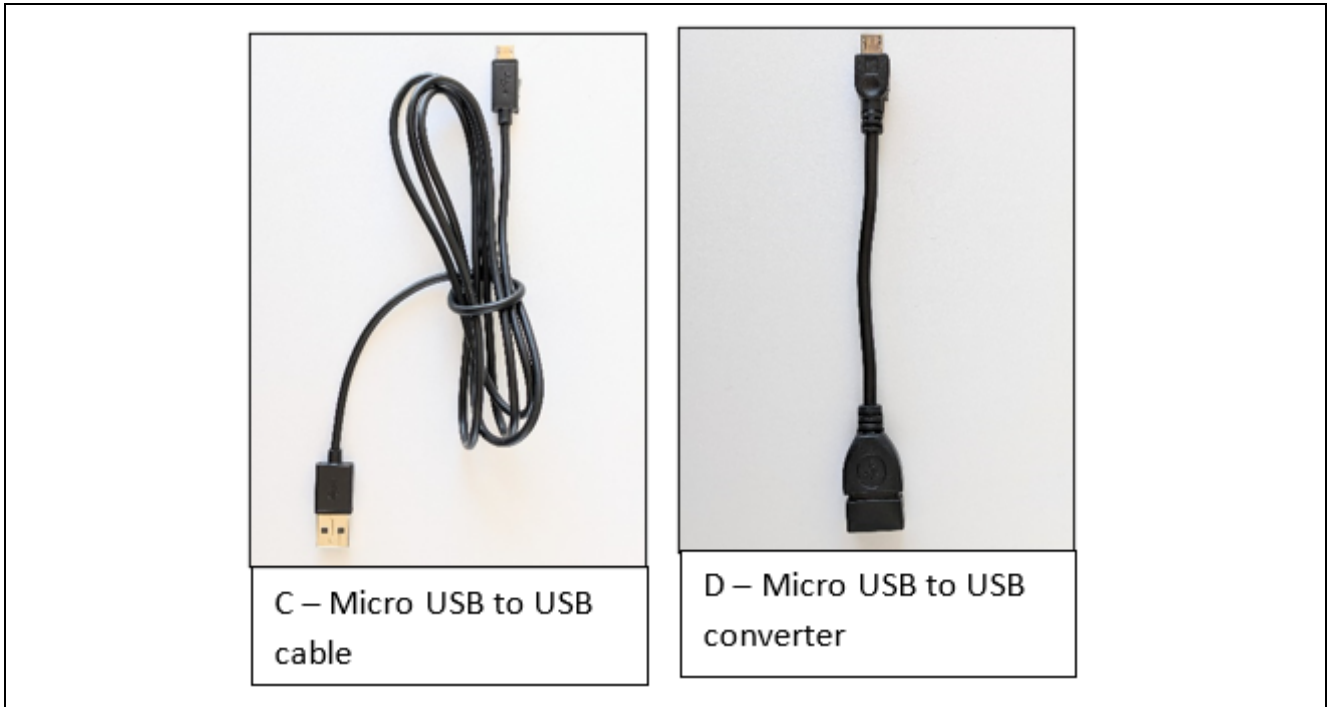

Figure 4. Cable C to Converter D

3. Plug adapter D (microUSB) into port B2

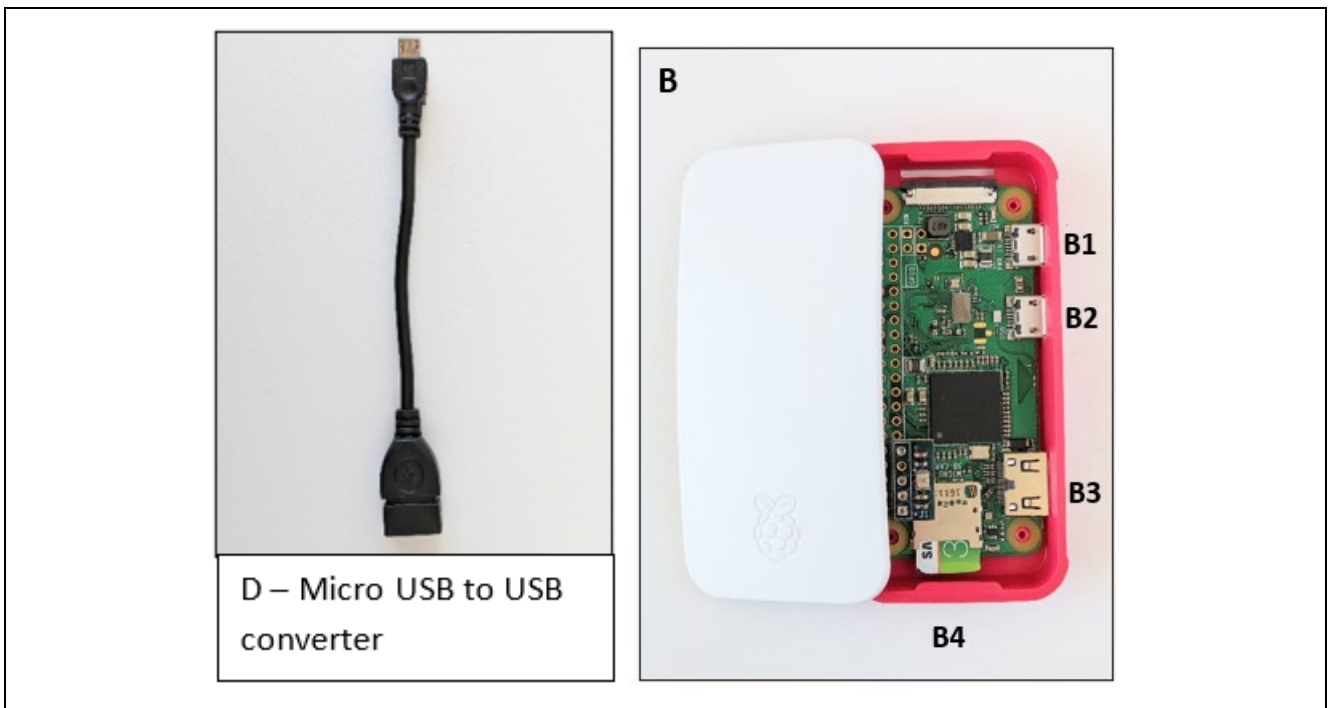

Figure 5. Converter D to Port B2

4. Insert  $\mu$ SD Card G into port A2

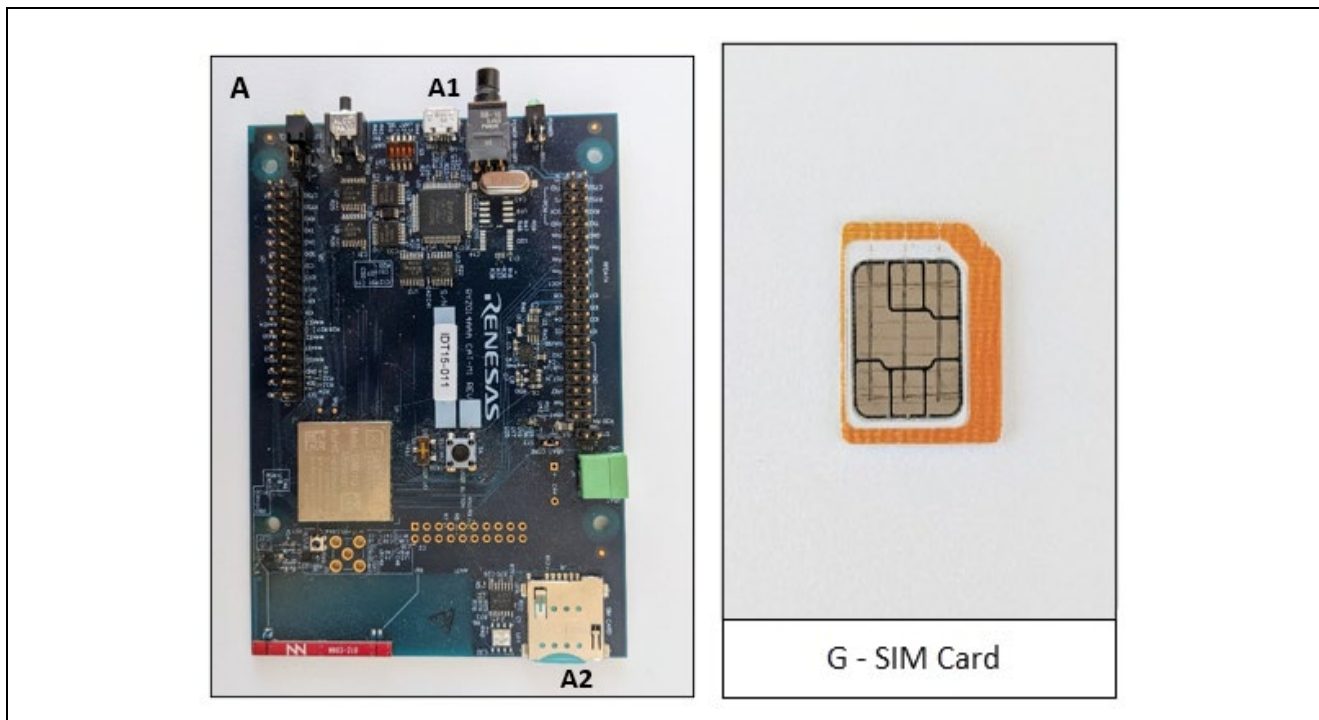

Figure 6. SIM Card to Port A2

5. Plug Power Cable E into port B1 (microUSB)

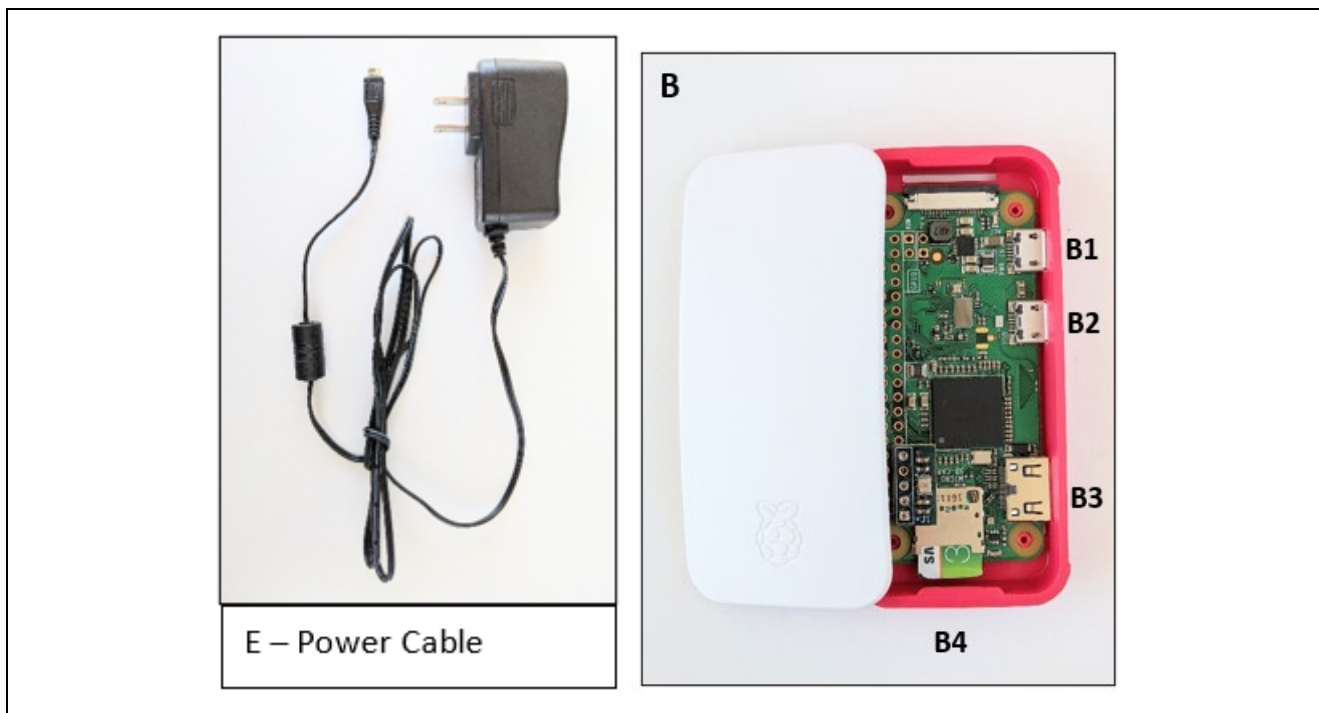

Figure 7. Power Cable to Port B1



6. Plug Power Cable into power
7. Using HDMI converter F is optional as the EVK can run headless



**Figure 8. HDMI Adapter**

8. Power on the device via the large power button on the CATM module if the LED is not green

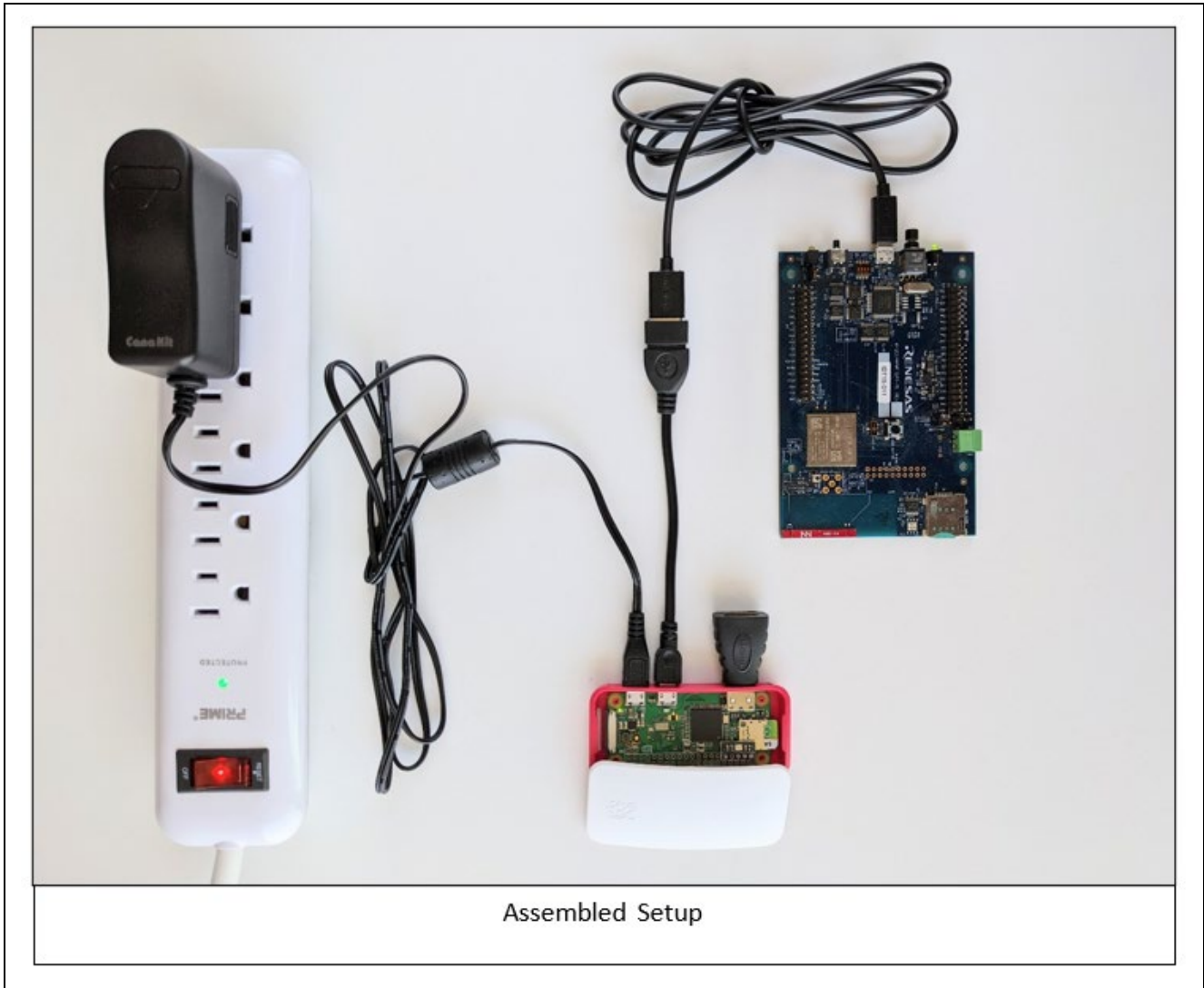

**Figure 9. Assembled Setup**

### 1.3 Install the Drivers

When plugging the USB cable in your PC first time, you need to wait for approximately one minute to allow the drivers auto-install on Windows.

The USB is used to power the board. It also connects the on-board UART-USB Bridge IC (FTDIc FT4232HL) to provide ACM interfaces (virtual COM) in order to access the board through UART.

If, for some reasons, the driver fails to auto-install on Windows, please install it manually from [www.ftdichip.com](http://www.ftdichip.com), where you can find the FTDI driver labelled UART/USB. After the driver installation, please unplug the RYZ014AAA Evolution Kit and reboot your PC.

After completing the driver's installation, whenever you plug the USB cable, devices are listed in device manager as shown on Figure 10.

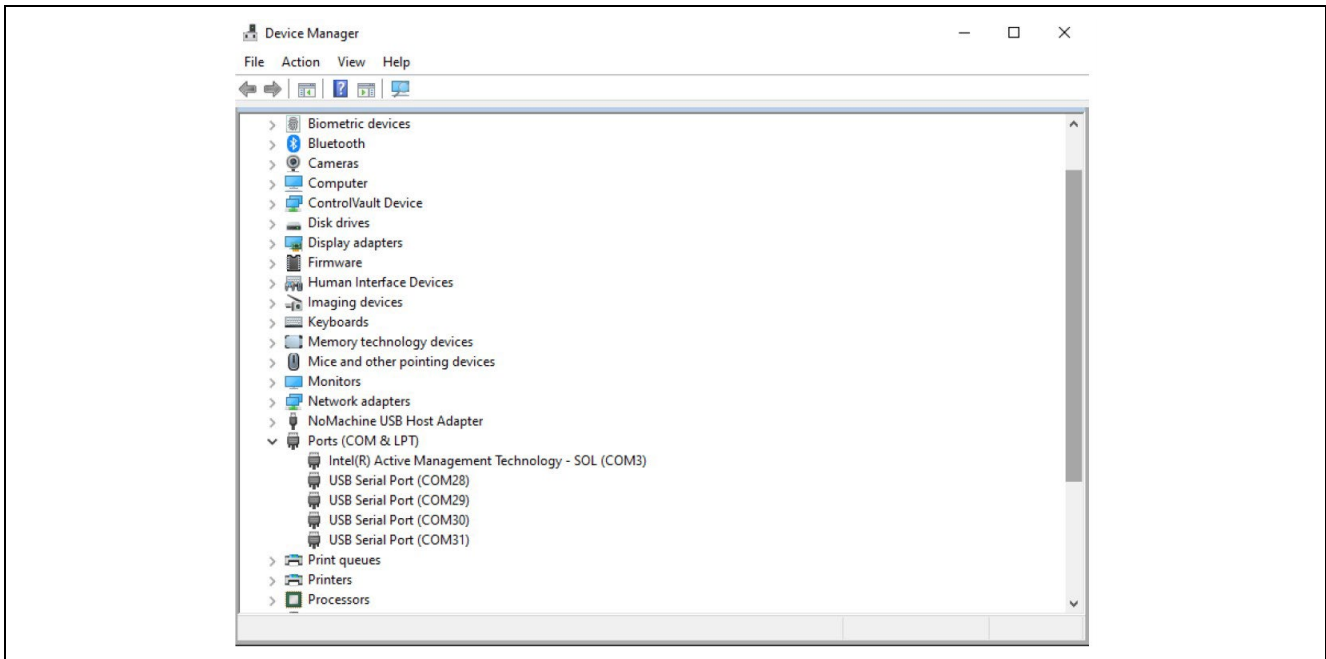

Figure 10. Device Manager Window

### 1.4 Set the COM Ports

The table below summarizes the COM ports under Windows and the corresponding configuration to the RYZ014AAA Evaluation Kit.

Table 1. COM Ports Setting

Port Enum <sup>1</sup>	Mapping	Usage	Baudrate	Data Bits	Flow Control	Parity	Stop Bit
COMa	UART0	AT Commands	921600	8	Hardware	None	1
COMb	UART1	Console	115200	8	None	None	1
COMc	UART2	Debug	921600	8	Hardware	None	1

**Note:** 1. In the example of this document, COMa is COM28, COMb is COM29 and COMc is COM30.

**Caution:** COM ports cannot be shared between two different applications in the same time. One of the applications will be in error in such configuration.

In order to send AT Commands to the RYZ014AAA Evaluation Kit, please use a Serial Terminal program under Windows such as TeraTerm freeware.

1. To send an AT command to the kit, you need to connect your Serial Terminal to the UART 0 port, corresponding to COMa on Windows enumeration, please refer to the above Table to determine the exact COM port on your PC.
2. Under Setup, Serial Port, choose the right configuration according to the above Table.
3. Once the correct setting is done, you should be able to start sending AT Commands and receiving their corresponding output.

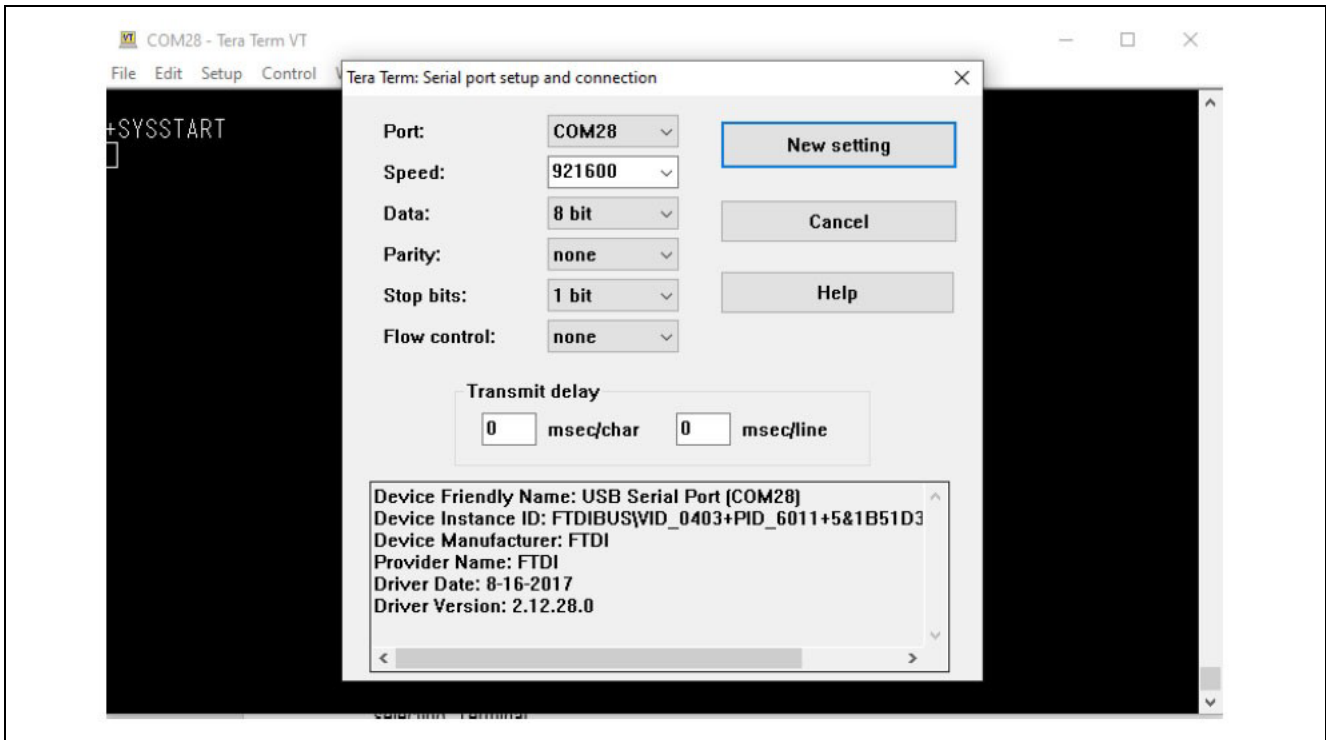

Figure 11. COM28 (COMa) Setting In Progress

### 1.5 Activate the SIM Card

A user account needs to be created to activate the SIM.

Step 1: Access URL <https://renesas.micro.ai/register>

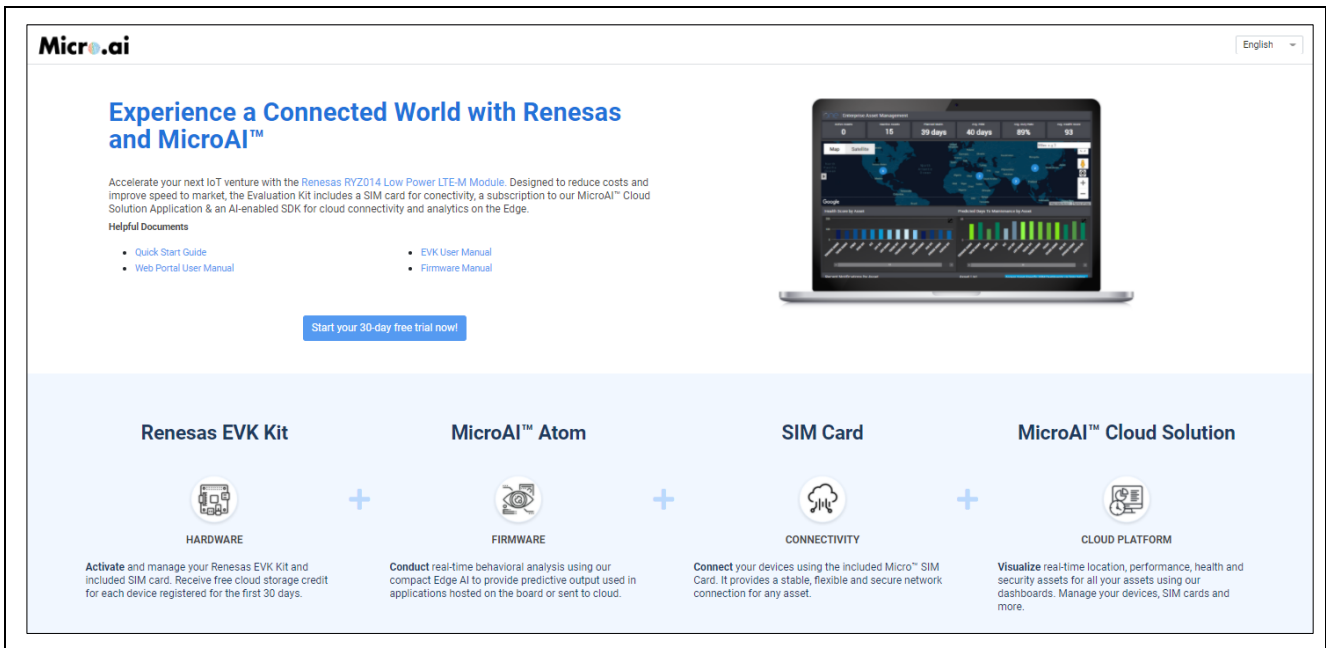

Figure 12. Access MicroAI

Step 2: Click **Start 30-day trial** and enter user details.

Step 3: Enter individual or company details.

The image shows a registration form titled "Start your free trial now". It is enclosed in a blue border with three numbered steps (1, 2, 3) at the top. The form includes the following fields and options:

- First Name\*** (text input)
- Last Name\*** (text input)
- Email\*** (text input)
- Country Code\*** (dropdown menu)
- Phone Number\*** (text input)
- Register as\*** (radio buttons for **Company** and **Individual**, with **Individual** selected)
- Add my info to mailing list for new products, services and promotions.**

Below the form is a blue **Next Step** button, a link for **Existing User? Log in here**, and a disclaimer: "By creating a ONE Tech account, you are agreeing to accept our [Terms of Service](#). We are committed to your privacy. ONE Tech will only use the information you provide to contact you about our relevant content, products and services. You may unsubscribe from these communications at any time. For more information, check out our [Privacy Policy](#)."

**Figure 13. Register as Company or Individual**

The form is titled "Add your information" and is part of a three-step registration process. Step 1 (checked) is complete, and step 3 is the next step. The form contains the following fields:

- Company Name\* (text input)
- Address Line 1\* (text input)
- Address Line 2 (text input)
- Country\* (dropdown menu)
- City\* (text input)
- State/Province\* (dropdown menu)
- Zip Code\* (text input)
- Currency\* (dropdown menu, currently set to "US.Dollars (\$USD)")

At the bottom of the form are two buttons: "Previous Step" (dark blue) and "Register Account" (blue).

Figure 14. Enter Information

Step 4: Access your email for the verification code and click validate button to create password

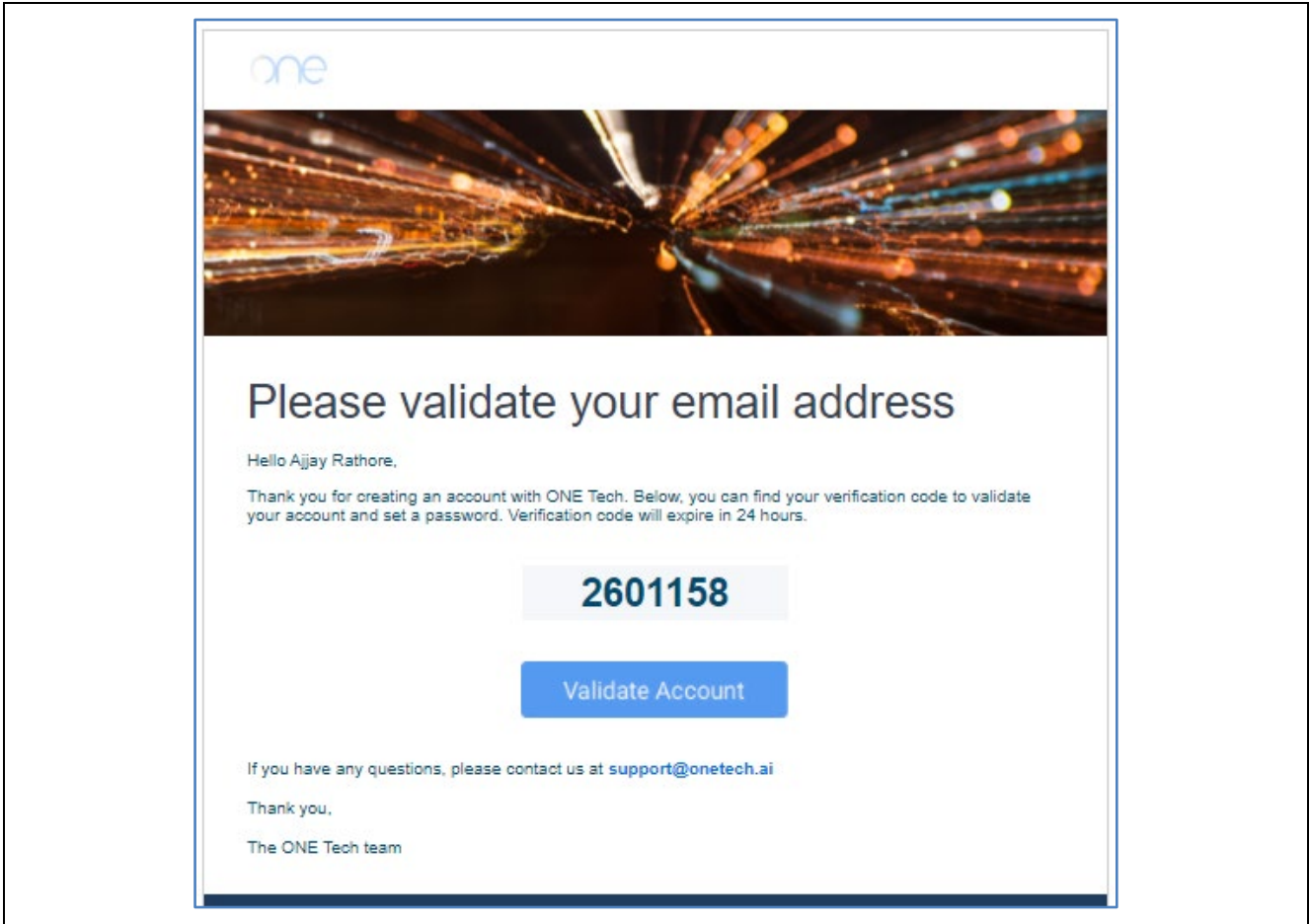

Figure 15. Validate Email Address

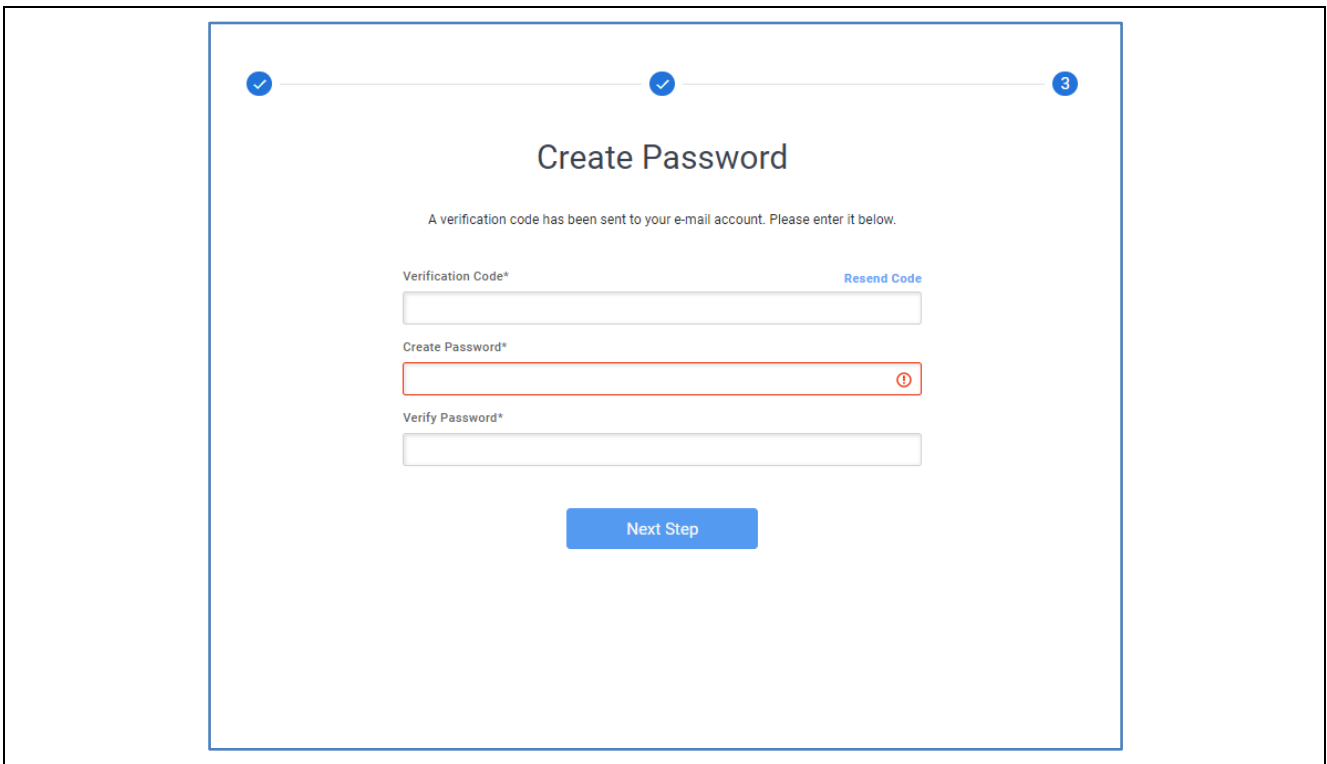

Figure 16. Create Password

Step 5: Access Homepage

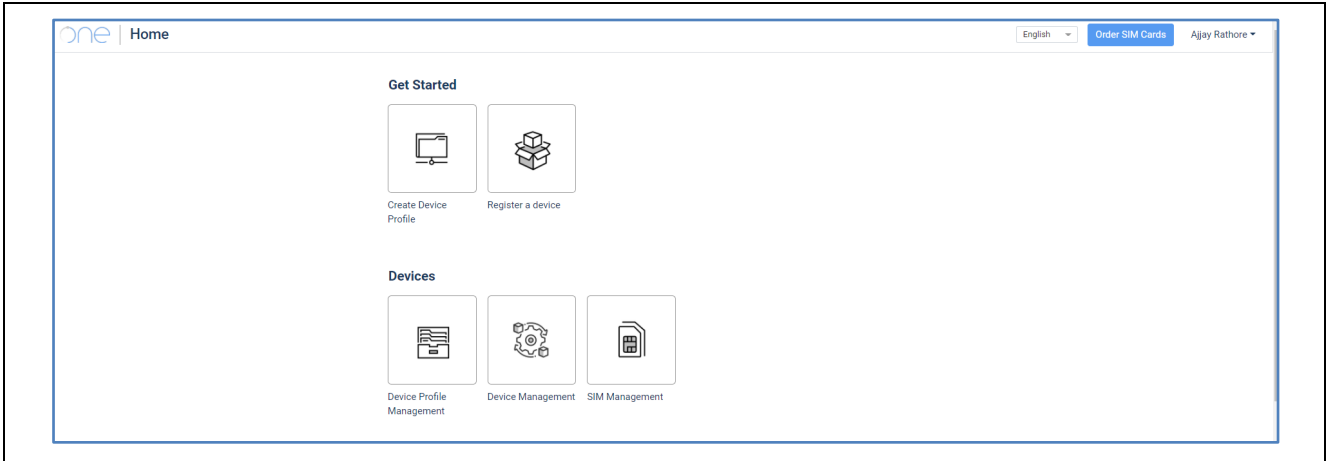

Figure 17. Access Homepage

Step 7: Click on **Create Device Profile** application tile

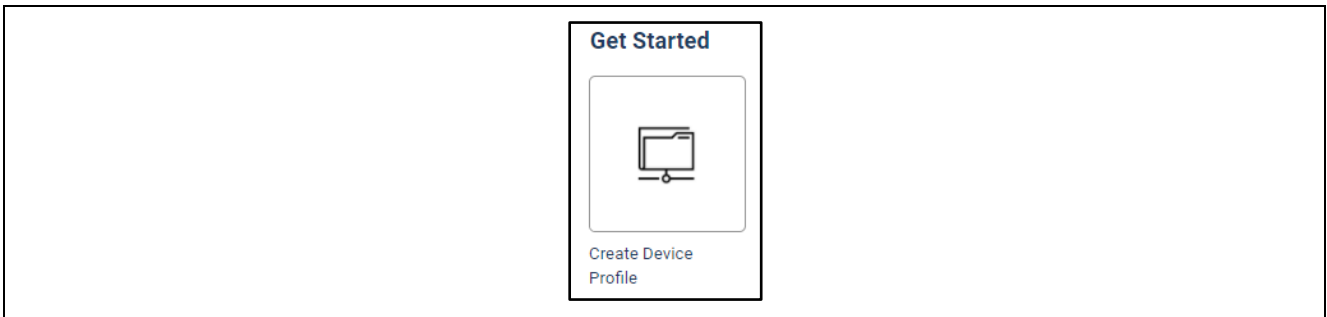

Figure 18. Create Device Profile

Step 8: Verify prefilled information and click next

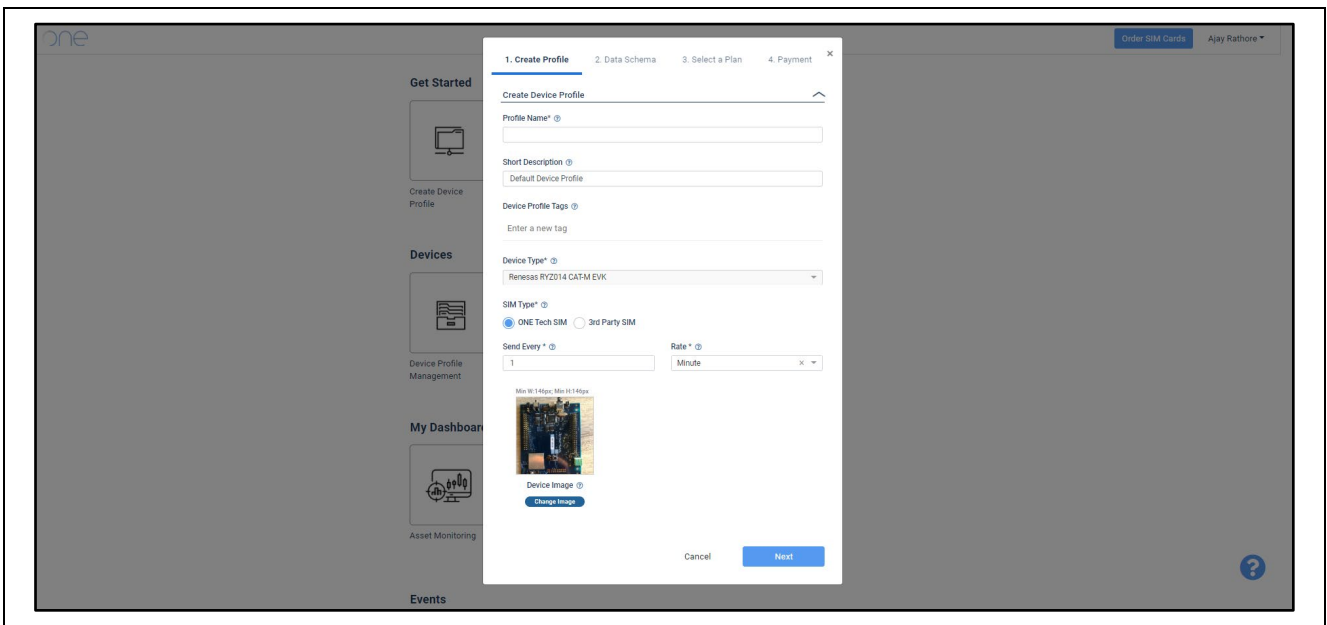
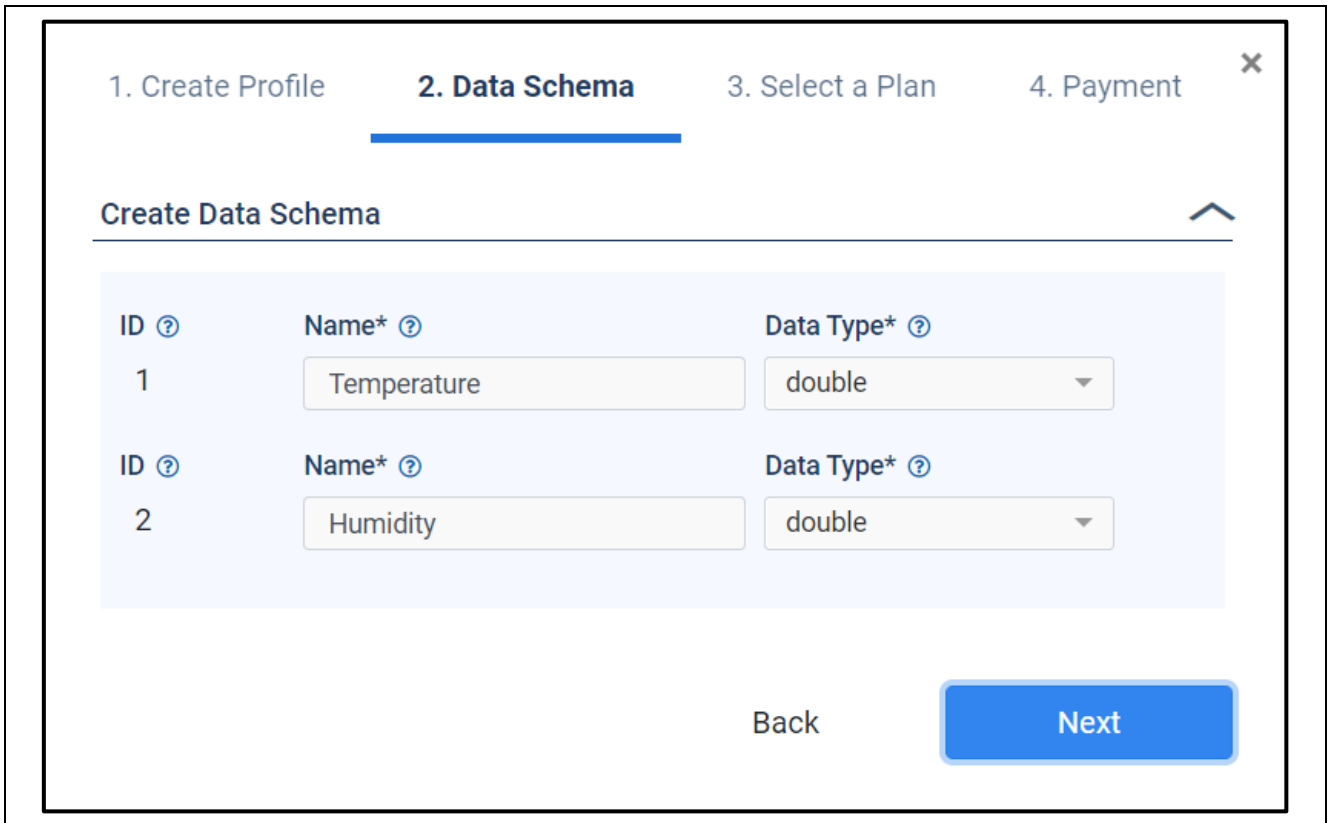

Figure 19. Verify Information

Step 9: Verify the sensors that will be configured on the device

**Note:** The kit comes with a schema (Temperature and Humidity) preinstalled on the device.

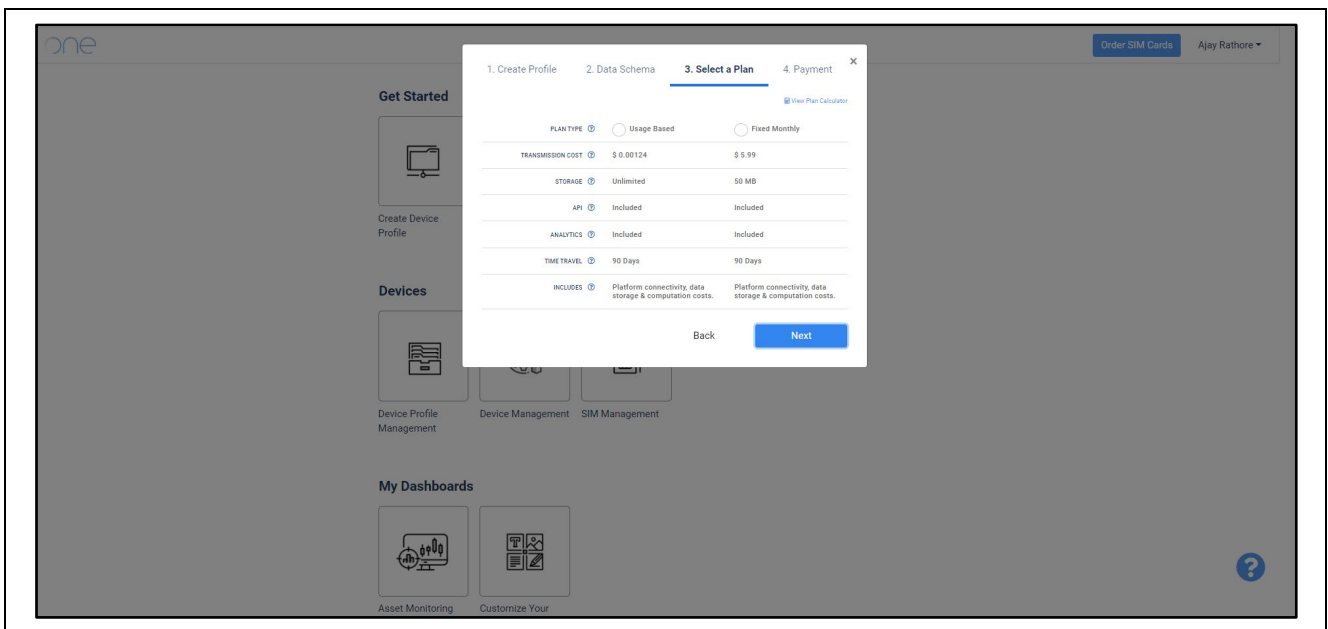



**Figure 20. Preinstalled Schemas**

Step 10: Select a payment plan

**Note:** The first 30 days are free. Once you register the EVK using mobile app, you will get a \$5.99 credit in your wallet



**Figure 21. Select Payment Plan**

Step 11: Add or select a payment method and click on finish

- Add credit card
- Add billing address

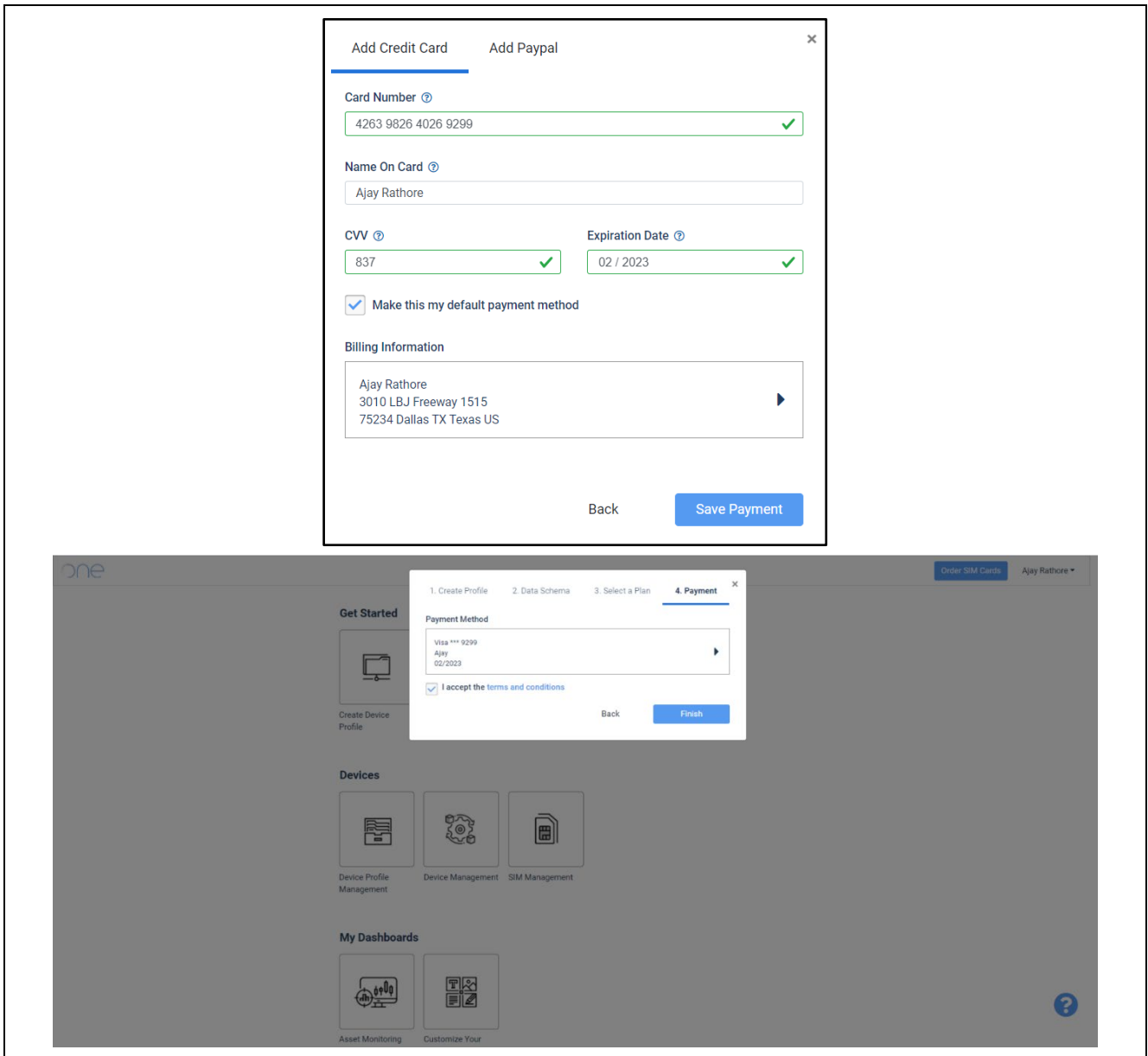

Figure 22. Add Credit Card and Billing Information

Step 12: Download the mobile app

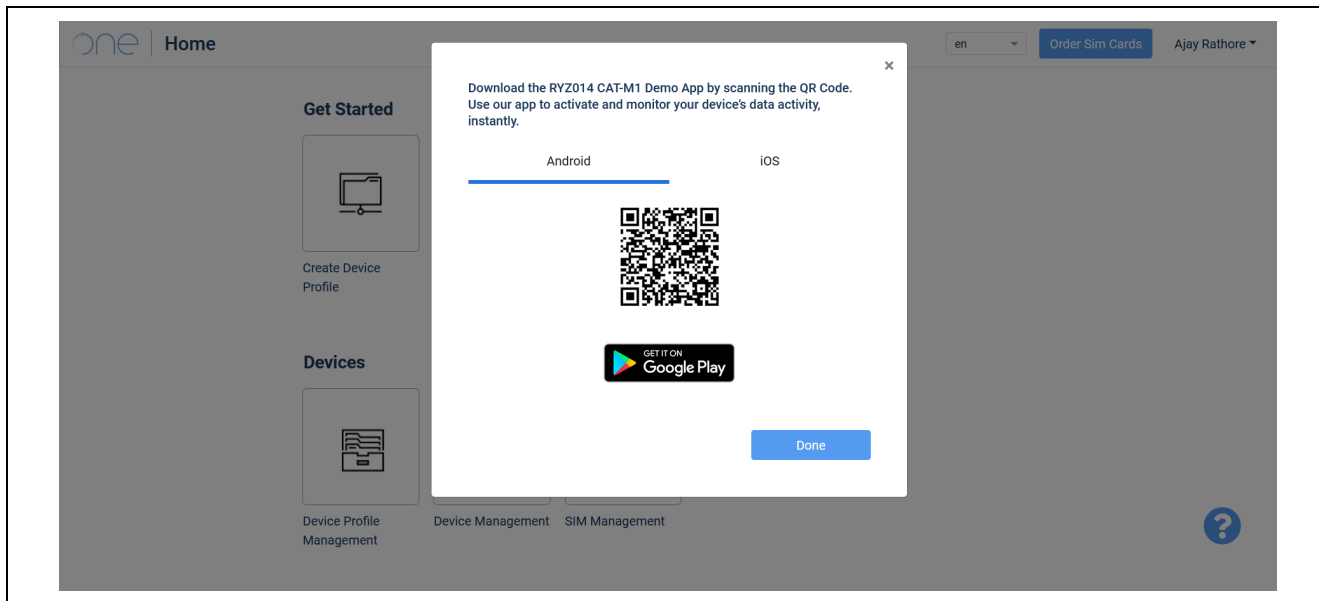

Figure 23. Mobile App

- IOS:
  - App Name: ONE Device
  - App Store Link: <https://apps.apple.com/us/app/one-device/id1558929605>
  - QR Code:



Figure 24. IOS App QR Code

- Android:
  - App Name: ONE Connect
  - Play Store Link: [https://play.google.com/store/apps/details?id=com.renesas\\_ryz014a.ble](https://play.google.com/store/apps/details?id=com.renesas_ryz014a.ble)
  - QR Code:

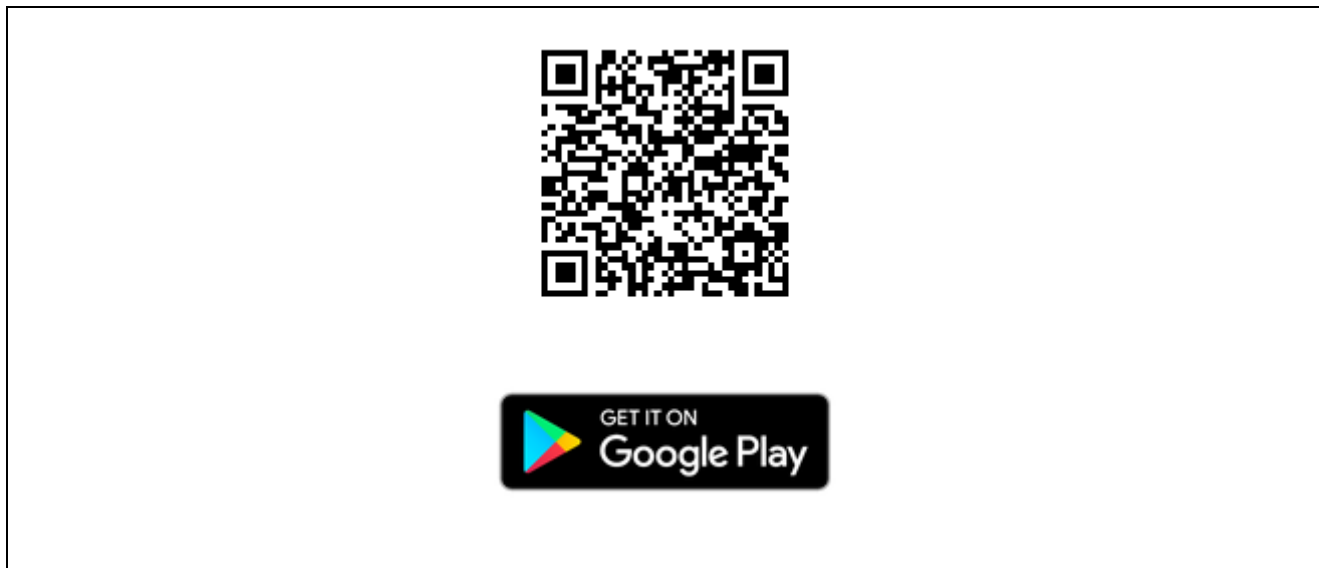

Figure 25. Android App QR Code

Step 13: Open the mobile app

Step 14: Select device from the list

Step 15: Drag down the list if you don't see your device

**Note:** The drag down functionality is only needed on Android. The iOS version does this automatically

Step 16: Click on your device and click on **Activate Device**

Step 17: Enter the MicroAI credentials you created on web portal

Step 18: Click **Get Device Configuration**

Step 19: Select device profile you created on web portal

Step 20: Click on **Activate Device**

Step 21: The app automatically takes you to monitor device screen

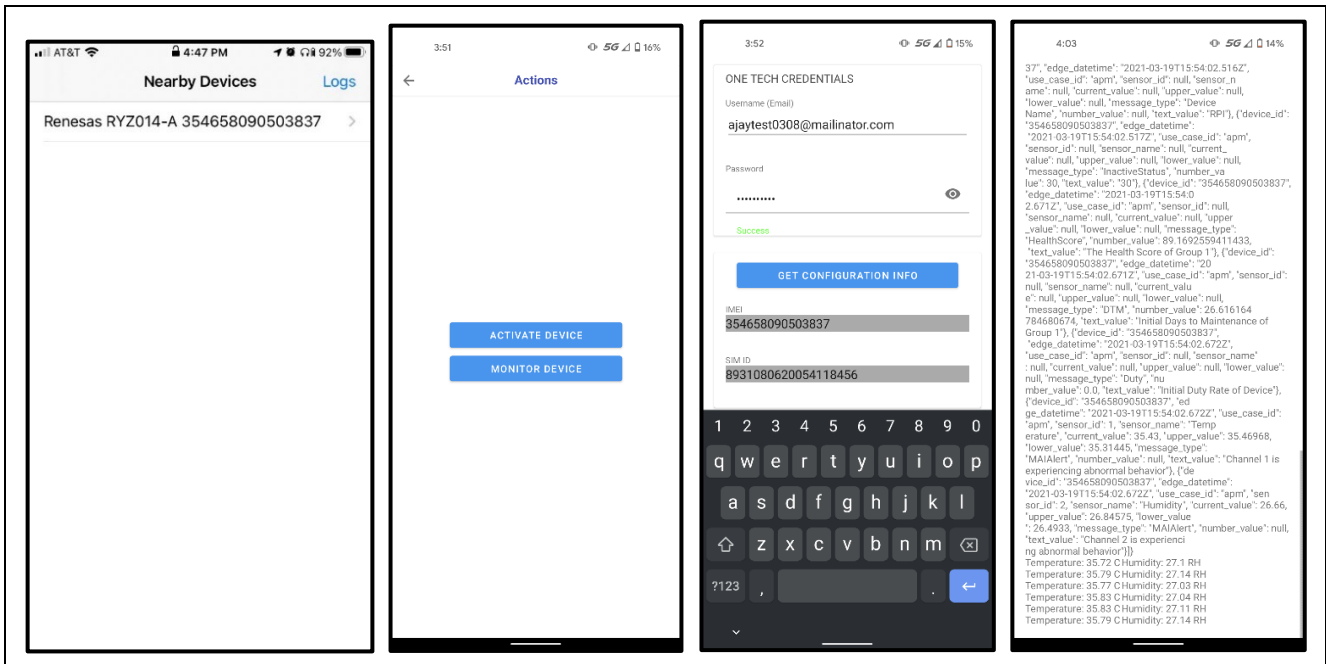

Figure 26. Activate Device in App

## 1.6 Configure Supported Operators

**Note:** The SIM card will be read when the UE is in +CFUN=1 or +CFUN=4 states. When the SIM card is read for the first time, the modem will be reconfigured automatically and will reboot.

RYZ014AAA is provided with a SIM card. In order to check the supported operators, please refer to this [link](#)

The modem can support up to 17 LTE bands. Scanning all the bands takes several minutes. In order to reduce the scanning duration, it is possible to configure the list of bands that need to be scanned with the AT+SQNBANDSEL command. Please refer to the *AT Commands Reference Manual* or the *Use Cases with AT Commands* documents for more details.

## 1.7 Connect to LTE Network

**Important:** All actions described in this section apply when you have access to an LTE network or simulator.

1. Press the POWER button of the RYZ014AAA host board and check the COM port enumeration in Windows Device Manager.
2. Open a Teraterm session on the AT command UART (UART0) COM port. The baud rate is 921600.
3. Configure the bands to be scanned:

```
AT+SQNBANDSEL=0,"standard","bands_to_be_scanned" AT+SQNCTM?
```

Check that this returns "standard". Otherwise, change it to standard operator mode with AT command AT+SQNCTM="standard". This command will trigger a reboot of the modem.

**Note:** Please note that these configurations are persistent at reboot and should be entered only once.

4. Enter AT command AT+CFUN=4 and check the SIM card interface state with AT+CPIN?. The response can be one of:
  - +CPIN: Ready: SIM card is present and unlocked
  - +CPIN: SIM PIN: Modem is waiting SIM PIN to be entered
  - +CPIN: SIM PUK: Modem is waiting SIM PUK to be given
  - ERROR, when SIM is not inserted or not detected
5. Control the presentation of an unsolicited result code by sending AT+CEREG=2. This command will allow getting notification every time there is a change of the network registration status.

6. Power on modem by sending AT command `AT+CFUN=1`. The response will be `OK` followed by `+CEREG=<stat>`.

**Table 2. Status Codes**

Value	Meaning	Comment
0	Modem is not registered and is not currently searching an operator to register to.	Possible cause: SIM card error or registration ongoing.
1	Modem is registered on network. Kit is connected.	
2	Modem is not registered but is currently trying to attach or is searching for an operator to register to.	Possible causes: No network available, available networks have bad coverage, PLMN available but the registration is rejected.
3	Registration denied.	Possible causes: Illegal mobile equipment IMSI unknown at HLR, PLMN not allowed, Location area not allowed, Roaming not allowed in this location area, Network failure, Network congestion.
4	Unknown.	Transitory value
5	Modem Registered in roaming mode	

7. End-to-end connectivity can be tested with the following AT command  
`AT+PING="www.Renesas.com"`.

## 2. Hardware Description

### 2.1 Overview

The Top and Bottom Assembly views of the RYZ014AAA are represented in Figure 27 and Figure 28.

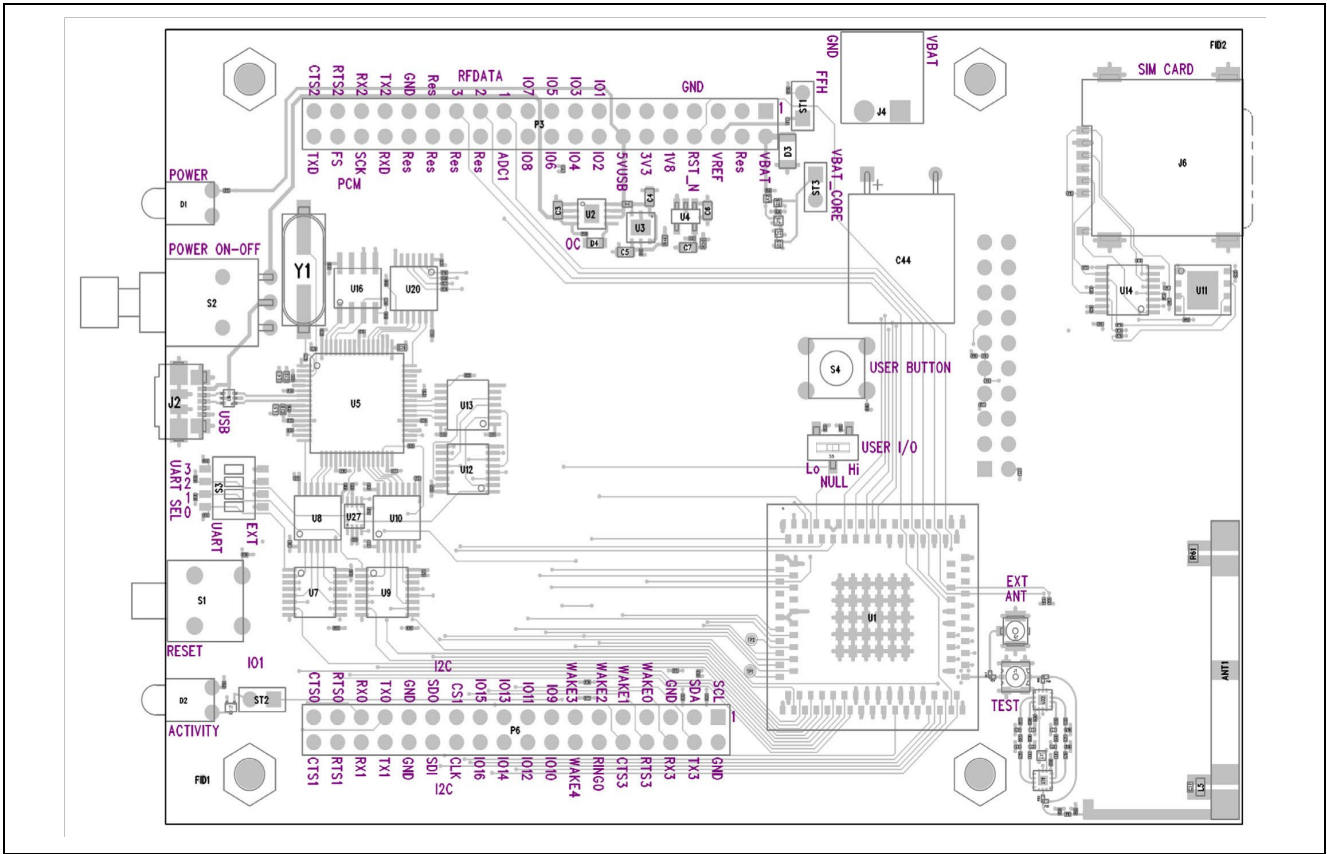

Figure 27. Top Assembly

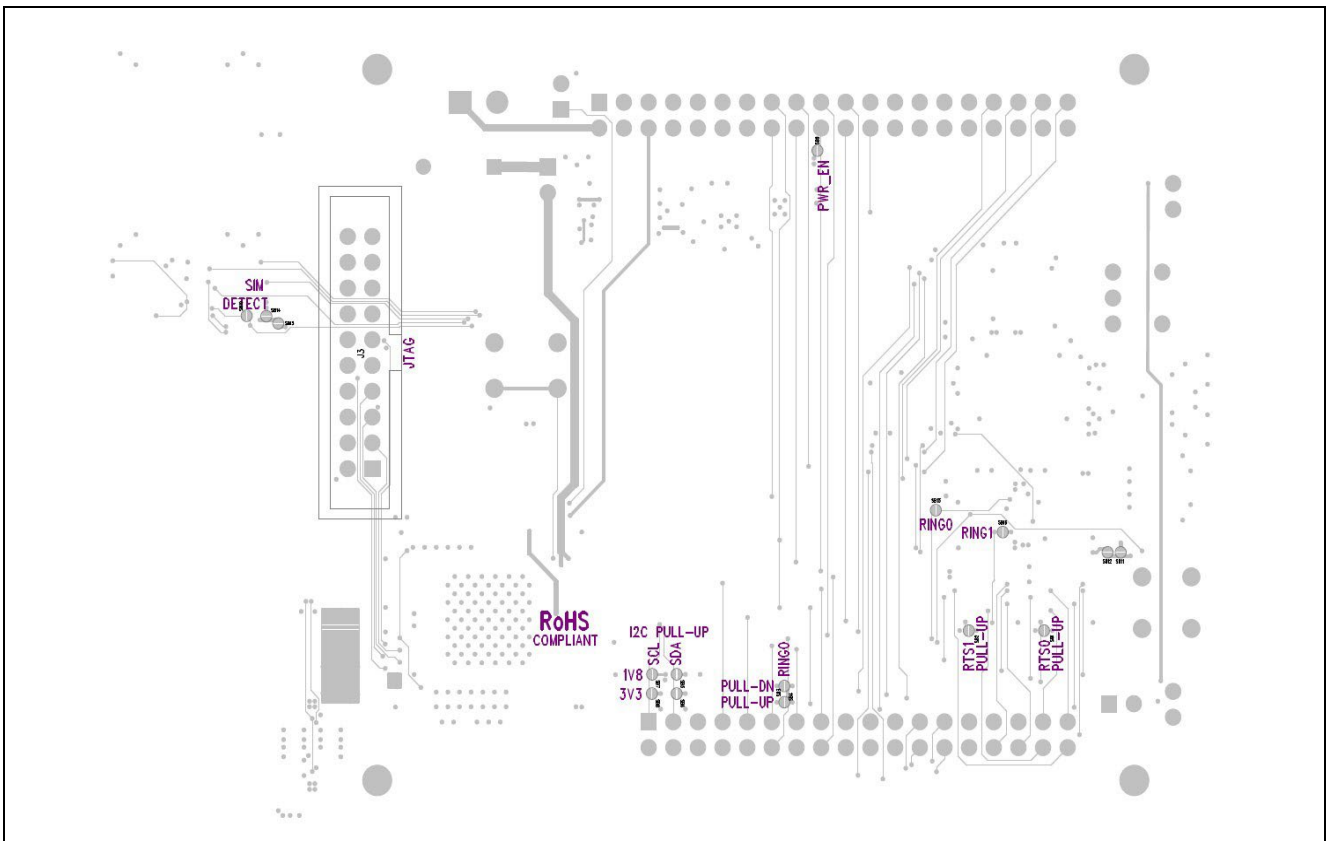
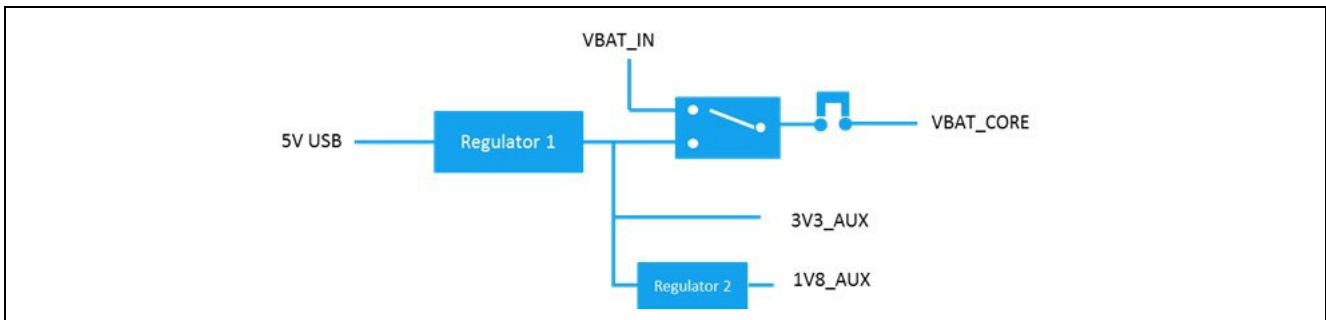

Figure 28. Bottom Assembly

## 2.2 Power Supplies

RYZ014AAA has two power domains:

1. One power domain for the entire auxiliary and debug circuitry (AUX).
2. One power domain for the LTE modem (CORE).



**Figure 29. RYZ014AAA Power Supplies**

The auxiliary power domain can only be powered via USB.

The LTE modem can be powered in three different ways: USB, VBAT\_IN, VBAT\_CORE.

- USB  
When USB is connected, and no other voltage is applied to the board, a regulator generates 3.3V\_AUX which is used to power the LTE modem
- VBAT\_IN  
VBAT\_IN is available on J4 connector and on pin 2 on connector P3. VBAT\_IN must respect the voltage range defined by the module in RYZ014AAA board. When VBAT\_IN is above 1.6V, the module power VBAT\_CORE is automatically switched from the 3V3\_AUX to the VBAT\_IN supply.

**Note:** When the LTE module is powered via VBAT\_IN, there is some extra leakage on the power supply circuitry itself as per Table 3. Therefore, it is not recommended to use this power supply when measuring the LTE module rock bottom current.

**Table 3. Power Leakage if Power by VBAT\_IN**

V	mA	mW
2.9	0.0194	0.05626
3.1	0.0191	0.05921
3.3	0.019	0.0627
3.8	0.0192	0.07296
4.5	0.0199	0.08955

See also Section 3.1, How to Connect an External Power Supply on page 27

- VBAT\_CORE  
The module VBAT\_CORE is available on ST3 jumper. By disconnecting ST3 jumper, the LTE module can be powered directly with an external supply. This setup is recommended when measuring the module's rock bottom.

See also Section 3.2, How to Connect a Series Current Meter on page 27.

## 2.3 Power-On and Reset

RYZ014AAA has two buttons to control power and reset:

- Reset push button (S1): resets the module when pressed.
- Power toggle button (S2): cuts USB power ON/OFF

## 2.4 USB Port and UART Switches

RYZ014AAA provides access to all the LTE modem UARTs via the USB connector.



Each individual UART can be redirected to the expansion connector via the S3 switch. When the switch is in the "UART" position the UARTs are redirected to the USB port:

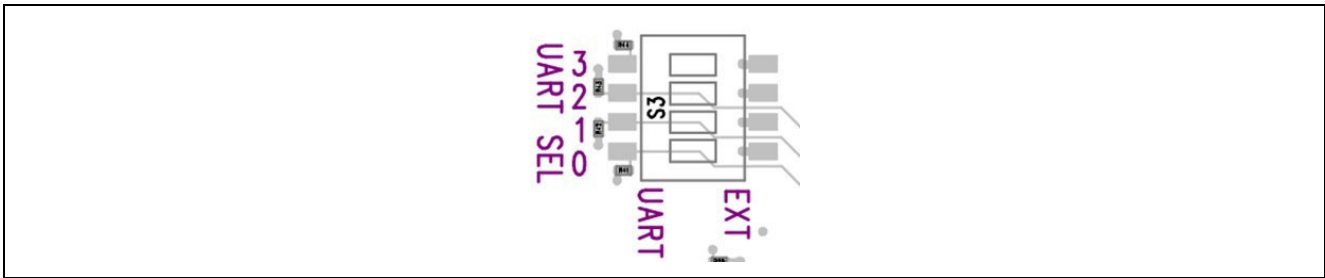

Figure 30. UART Switches

### 2.5 SIM Card

RYZ014AAA supports connectivity from an MFF2 SIM (U11) or from a SIM slot (J6). Both solutions connect to RYZ014A SIM0 interface. A multiplexer automatically selects between the embedded MFF2 SIM and the SIM slot as per :

- When a SIM card is plugged into the push-eject SIM slot (J6), this will be used to connect to the modem
- If a MFF2 SIM is soldered into U11 and the soldering bridge SB10 is configured as OPEN, then on the absence of SIM card in J6, the modem will default to use the SIM soldered into U11.

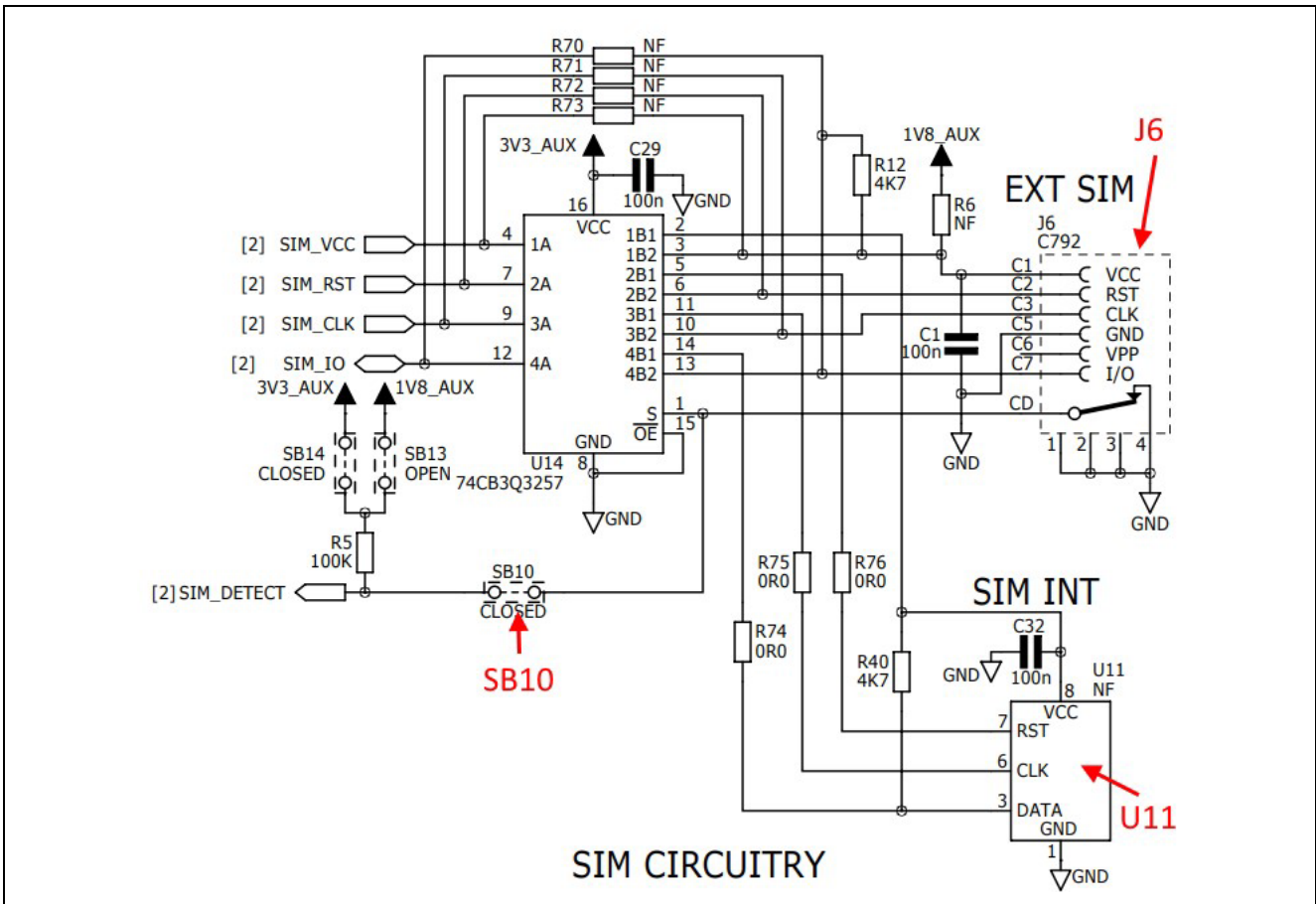

Figure 31. SIM Circuitry

## 2.6 LEDs

Two LEDs are present in the board:

- Power LED (D1): turns on whenever there is USB power
- Activity LED (D2): turns according to network activity if ST2 jumper is fitted and the ACTIVITY LED function is enabled on the module (with AT command `AT+SQNLED`, please refer to *AT Commands Reference Manual* for details.)

## 2.7 User Button and Switch

RYZ014AAA board provides a user button (S4) and a user switch (S5).

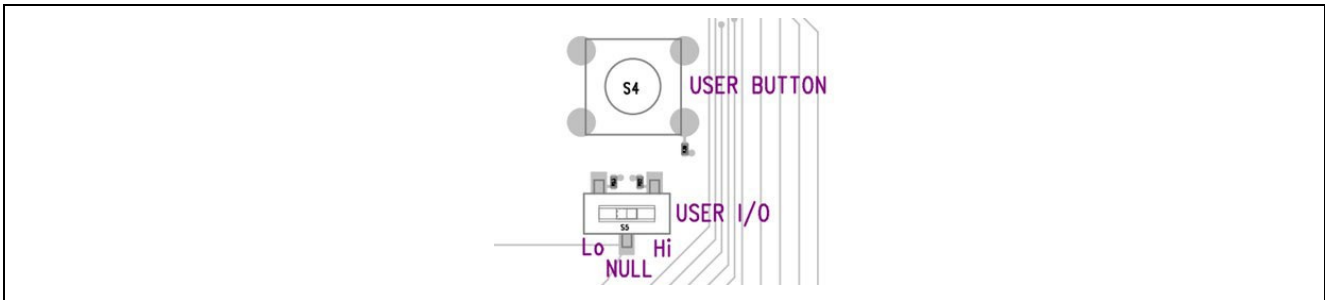

Figure 32. User Button and Switch

## 2.8 Expansion Connectors

The expansion connectors for RYZ014AAA boards are intended to:

- Allow hardware designers to connect external peripherals for prototyping.

Two expansion connectors are available on RYZ014AAA board. They provide access to all the modem interfaces.

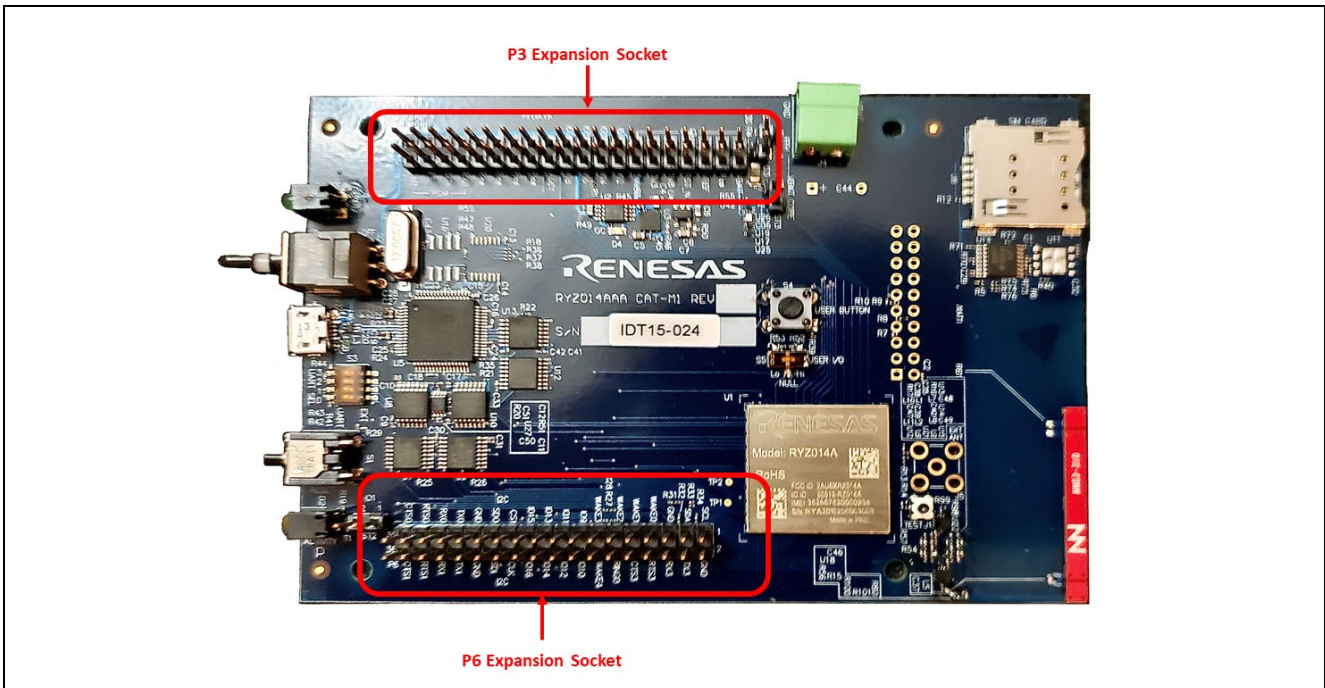

Figure 33. Expansion Connectors Location on RYZ014AAA Board

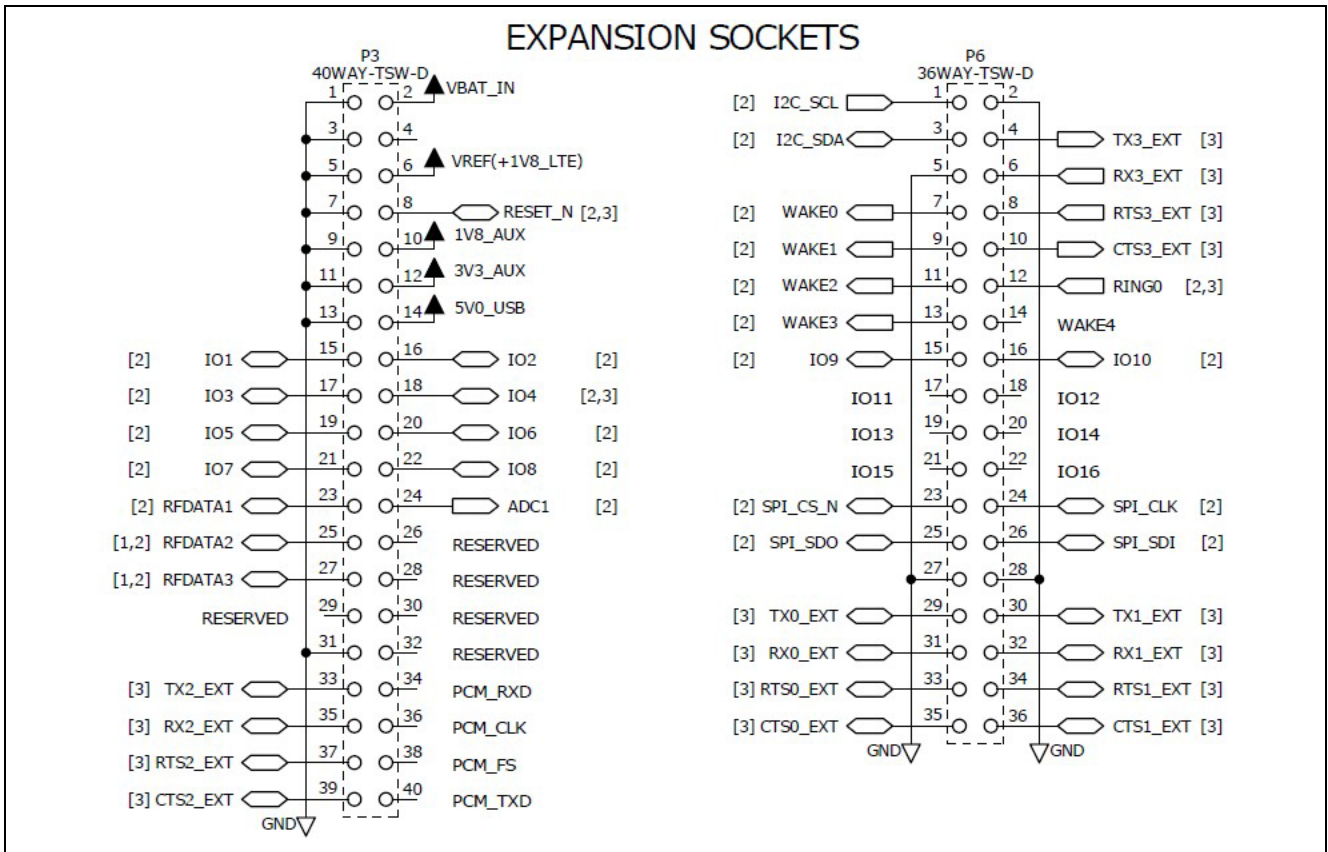

Figure 34. Expansion Connectors Schematics

Table 4 provides the correspondence between the expansion connector signals and the module signals.

Table 4. Expansion Connectors and RYZ014A Signals

P3 Connector Signals to RYZ014A Module				P6 Connector Signals to RYZ014A Module			
P3 Pad	P3 Marking	Direction	RYZ014A Signal	P6 Pad	P6 Marking	Direction	RYZ014A Signal
1	GND	-	-	1	I2C_SCL		I2C_SCL
2	VBAT_IN	I	VBAT	2	GND	-	-
3	GND	-	-	3	I2C_SDA		I2C_SDA
4	-	-	-	4	TX3	I	-
5	GND	-	-	5	GND	-	-
6	VREF (1V8 LTE)	O	1V8	6	RX3	O	-
7	GND	-	-	7	WAKE0	*	GPIO11/ WAKE0
8	RESETn	I	RESETN	8	RTS3	I	-
9	GND	-	-	9	WAKE1	*	GPIO12/ WAKE1
10	1V8_AUX	O	-	10	CTS3	O	-
11	GND	-	-	11	WAKE2	*	GPIO39/ DSR0

P3 Connector Signals to RYZ014A Module				P6 Connector Signals to RYZ014A Module			
P3 Pad	P3 Marking	Direction	RYZ014A Signal	P6 Pad	P6 Marking	Direction	RYZ014A Signal
12	3V3_AUX	O	-	12	RING0	O	RING0
13	GND	-	-	13	WAKE3	*	GPIO41/ DTR0
14	5V_USB	O	-	14	WAKE4	*	-
15	IO1	IO	GPIO3/ STATUS_LED	15	IO9	IO	GPIO29/ 32KHZ_OUT
16	IO2	IO	GPIO2/ PS_STATUS	16	IO10	IO	GPIO42/ SAR_DETECT
17	IO3	IO	GPIO19/ CLK0	17	IO11	IO	-
18	IO4	IO	GPIO38/ CLK1	18	IO12	IO	-
19	IO5	IO	GPIO40/ EMGCY_SHDN	19	IO13	IO	-
20	IO6	IO	POWER_EN	20	IO14	IO	-
21	IO7	IO	GPIO26/ CLK2	21	IO15	IO	-
22	IO8	IO	GPIO21	22	IO16	IO	-
23	RFDATA1	IO	RFDATA12	23	SPI_CS1	IO	SPI_CSN
24	ADC1	I	ADC1	24	SPI_CLK	IO	SPI_CLK
25	RFDATA2	IO	RFDATA16	25	SPI_SDO	IO	SPI_SDO
26	Reserved	-	-	26	SPI_SDI	IO	SPI_SDI
27	RFDATA3	IO	RFDATA17	27	GND	-	-
28	Reserved	-	-	28	GND	-	-
29	Reserved	-	-	29	TX0	I	TXD0
30	Reserved	-	-	30	TX1	I	GPIO14/ TXD1
31	GND	-	-	31	RX0	O	RXD0
32	Reserved	-	-	32	RX1	O	GPIO15/ RXD1
33	TX2	I	TXD2	33	RTS0	I	RTS0
34	PCM_RXD	I	-	34	RTS1	I	GPIO16/ RTS1
35	RX2	O	RXD2	35	CTS0	O	CTS0
36	PCM_CLK	I	-	36	CTS1	O	GPIO17/ CTS1
37	RTS2	I	GPIO21/ RTS2				
38	PCM_FS	I	-				
39	CTS2	O	GPIO22/ CTS2				
40	PCM_TXD	O	-				

## 2.9 LTE Antenna and RF Connectors

The EVK features an integrated antenna with a matching circuit. The matching circuit is automatically driven by two of the module GPIOs depending on the operating frequency.

In addition, EVK features an RF connector (J1) allowing the board to be connected to an external antenna or test equipment. This connector is compatible with Murata® MXHS83QE3000 cable.

**Note:** When an external antenna is connected on J1 connector, the internal antenna is automatically disconnected.

Alternatively, an SMA connector can also be soldered on J5. This requires also adding a 0-Ohm resistor on R57 and removing R54, as shown below:

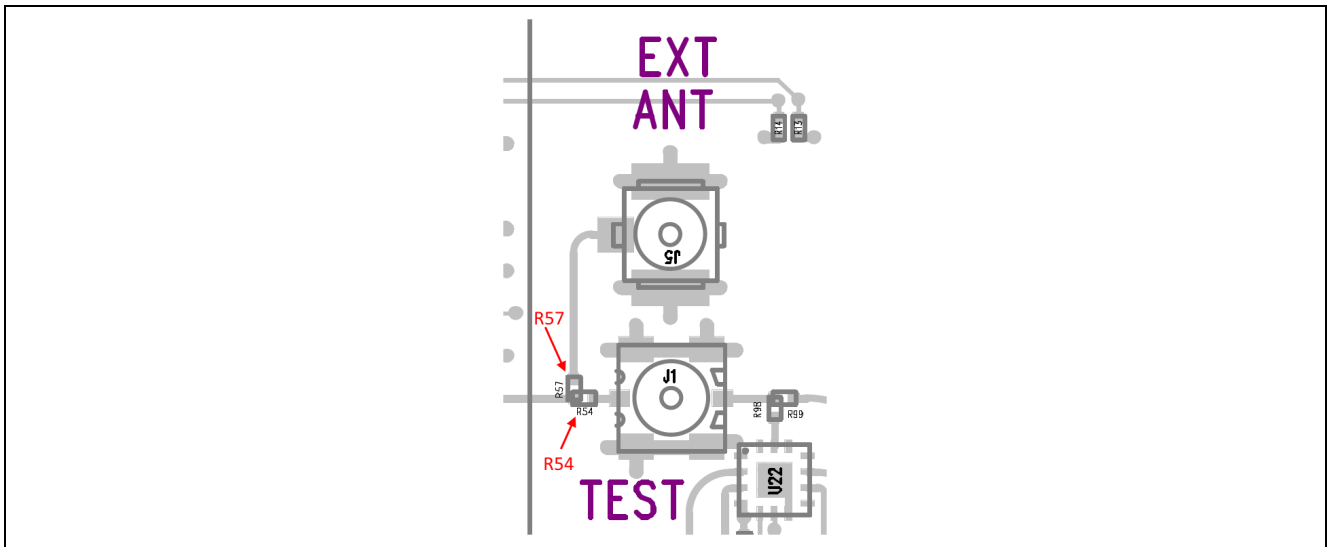

Figure 35. SMA Connector

## 2.10 Default Position for Jumpers and Switches

The below image shows the default position of all jumpers and switches in the board as manufactured by Renesas:

- ST2 and ST3 jumpers are fitted
- S3 is set in "UART" position in order to redirect the UARTs to the USB port

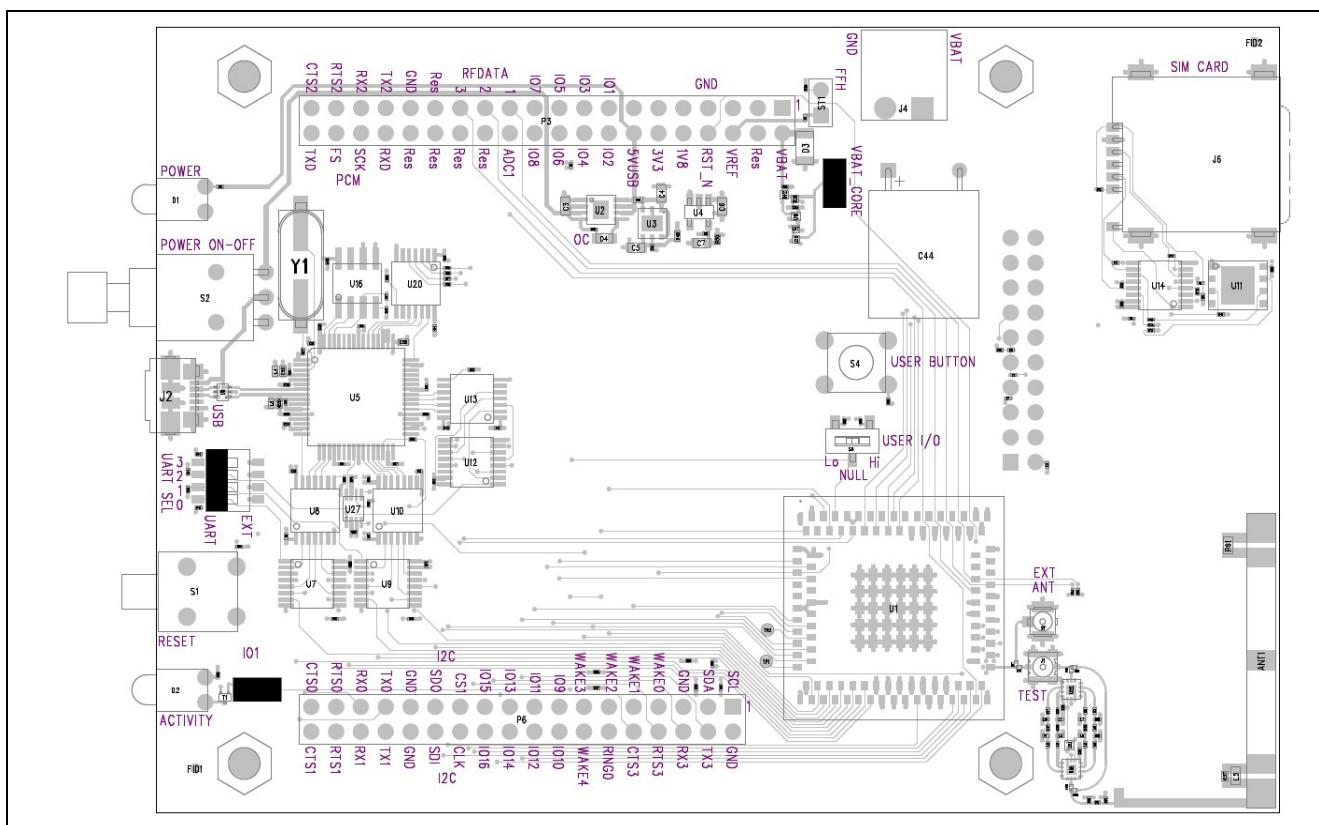

Figure 36. Default Jumpers and Switch Positions

### 3. Advanced Functions

#### 3.1 How to Connect an External Power Supply

##### 3.1.1 Power via VBAT\_IN on J4 Connector

The external power supply can be connected at the Power Input connector J4 (VBAT\_IN). When the supply voltage at VBAT\_IN is above 1.6 V, the module power VBAT\_CORE automatically switches from the 3V3\_AUX to the VBAT\_IN supply.

**Note:** J4 is a 2-way, 1-row, right angle PCB terminal block header. To connect to J4, a 3.81-mm pitch, 2-way PCB terminal block can be used.

##### 3.1.2 Power via VBAT\_CORE on ST3 Connector

The external power supply can be connected at ST3 VBAT\_CORE for the module VBAT1 to supply and measure power.

#### 3.2 How to Connect a Series Current Meter

Strap ST3 can also be used to connect a Series Current Meter. The module current must be measured from this point otherwise there is a risk of measuring additional current from the host board.

If a current measuring power supply is used, then the power should be connected to the strap ST3.

#### 3.3 How to Perform a Remote Reset

When using RYZ014AAA on a remote setup, it may be handy to have the means to reset the board remotely via the host PC. For this, RYZ014AAA can be reset via one of the UART1 ports available on the USB connector

To enable remote reset, fit a 10-kOhm resistor on R35.

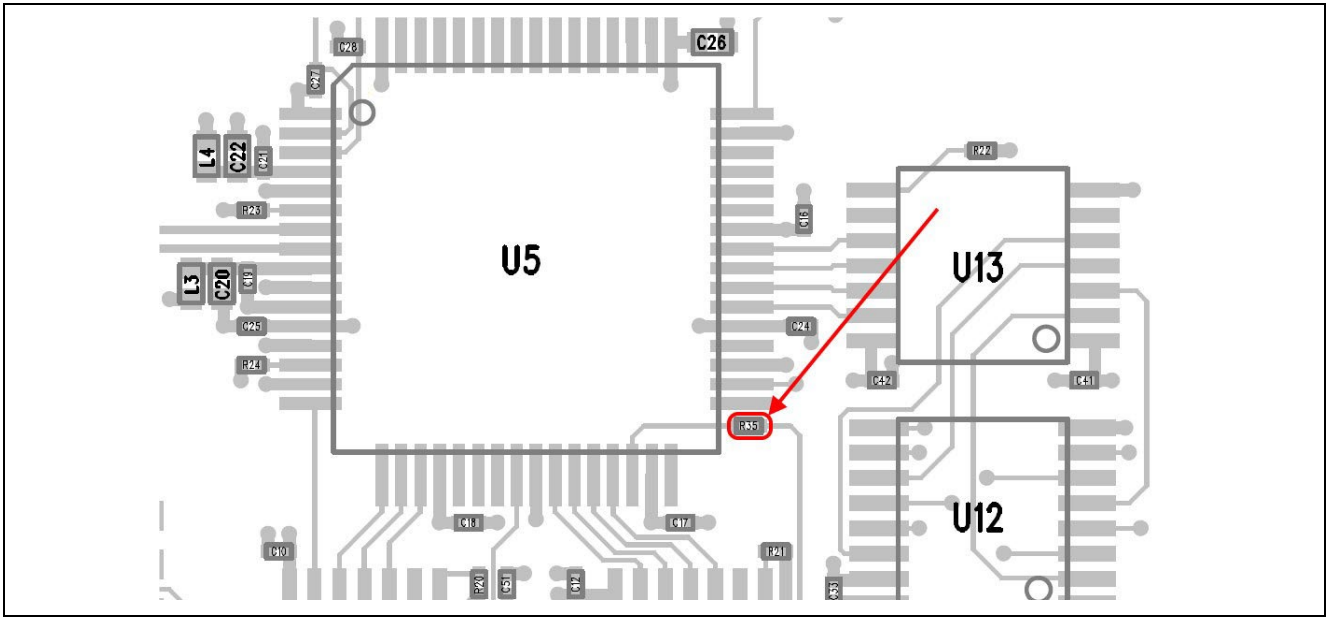

Figure 37. R35 Location on Layout

Remote reset is done by toggling the UART1 DTR pin to High-Low-High. This can be done using a TeraTerm script as shown below:

```

; change flow control to "none"
setflowctrl 3
; DTR Reset
setdtr 0
pause 1
setdtr 1
pause 1
setdtr 0
    
```

This script sets the DTR high for 1 second, and low for 1 second, and then high (to reset the platform).

### 3.4 How to Modify the Board by Soldering Bridges

**Caution:** Always check the schematics for the current revision of your board before changing solder bridges functions.

**Table 5. Solder Bridges Identification**

Solder Bridge #	Action
SB1	RTS0 pull up to 3V3_AUX
SB2	RTS1 pull up to 3V3_AUX
SB3	RING0 pull up to 3V3_AUX
SB4	RING0 pull down to GND
SB5	I2C_SDA pull up to 1V8_AUX
SB6	I2C_SDA pull up to 3V3_AUX
SB7	I2C_SCL pull up to 1V8_AUX
SB8	I2C_SCL pull up to 3V3_AUX
SB9	IO6 pull up to 3V3_AUX
SB10	SIM_DETECT connect to Switch in SIM holder J6
SB11	RESET_N pull up to 3V3_AUX
SB12	RESET_N pull up to 1V8_AUX
SB13	SIM_DETECT pull up to 1V8_AUX
SB14	SIM_DETECT pull up to 3V3_AUX
SB15	RING0 connect to FTDI Ring Indicator A
SB16	IO4 connect to FTDI Ring Indicator B

Figure 38 shows two fitted and two not fitted solder bridges.

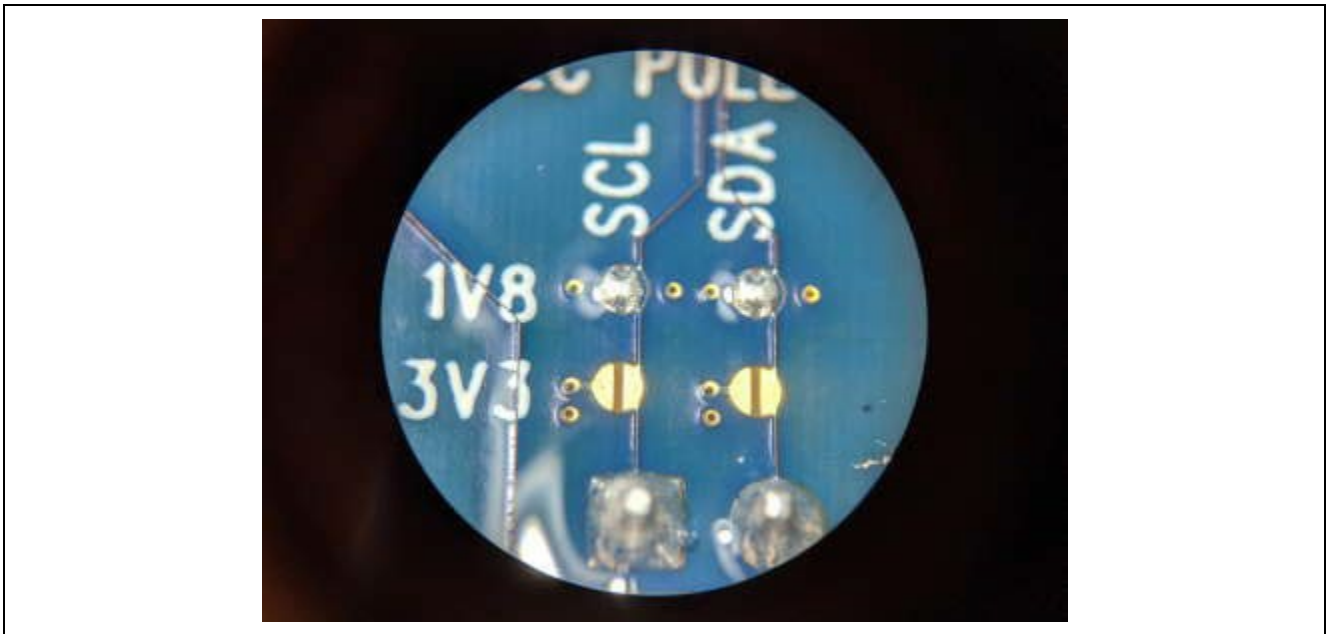

**Figure 38. Fitted and Not Fitted Solder Bridges**

Solder bridges can be fitted or removed using a single soldering iron to quickly make or break a connection as shown in Figure 39.





Figure 39. Single Soldering Iron on Solder Bridge

#### 4. Certification of Compliance

The RYZ014AAA complies with the laws and regulations described below

FCC: 2AU6XRZ014A

ISED: 20519-RZ014A

RE Directive:

Hereby, Renesas Electronics America Inc. declares that the radio equipment type RYZ014AAA is in compliance with Directive 2014/53/EU.

The equipment must be powered by a PS1 source in compliance with the 62368-1 standard.

Australia ACMA:

Japan MIC:

RYZ014A Module has obtained certified construction type certification (certification number: 003-200328).



R 003-200328

#### 5. Appendix: Glossary and Abbreviations

Abbreviation	Definition
FEM	Front-End Module
GPIO	General Purpose Input Output
I/O	Input/Output
I2C	Inter-Integrated Circuit
LED	Light Emitting Diode
LTE	3GPP Long-Term Evolution. See also <a href="https://www.3gpp.org/">https://www.3gpp.org/</a>
MFF2	Mini Form Factor 2 (SIM card format)
PCB	Printed Circuit Board
RF	Radio Frequency system
SIM	Subscriber Identity Module
RYZ014AAA	Renesas Module Evaluation Kit
UART	Universal Asynchronous Receiver-Transmitter
USB	Universal Serial Bus

## 6. About this Manual

### 6.1 Purpose and Scope

**Note:** This user manual is applicable to revision A3 (RYZ014AAA3). This can be identified in the board markings as P/N HWPT011A3 below Sequans' logo.

The purpose of this guide is to:

- Help RYZ014AAA users to understand their kit.
- Provide them with the set of procedures to start and configure the Evaluation Kit, connect to the network and setup a data connection.

**Note:** RYZ014AAA Evaluation Kit is dedicated to LTE Category M1 networks only. It supports Renesas' RYZ014A module.

### 6.2 Who Should Read this Document

This document is intended for any user of the Renesas' RYZ014AAA Evaluation Kit.

### 6.3 Changes in this Document

This is the first edition of the document.

### 6.4 References

Reference	Document Title
<i>AT Commands Reference Manual</i>	<i>AT Commands Reference Manual</i>
ITU-T V.250 <a href="http://www.itu.int/rec/T-REC-V.250-200307-I/en">http://www.itu.int/rec/T-REC-V.250-200307-I/en</a>	SERIES V: DATA COMMUNICATION OVER THE TELEPHONE NETWORK - Control procedures - Serial asynchronous automatic dialling and control
3GPP TS 27.007-13.5.0 <a href="http://www.3gpp.org/ftp/Specs/archive/27_series/27.007/27007-d50.zip">http://www.3gpp.org/ftp/Specs/archive/27_series/27.007/27007-d50.zip</a>	AT commands set for User Equipment
3GPP TS 27.005-13.0.0 <a href="http://www.3gpp.org/ftp/Specs/archive/27_series/27.005/27005-d00.zip">http://www.3gpp.org/ftp/Specs/archive/27_series/27.005/27005-d00.zip</a>	AT commands set for Short Message Service (SMS) and Cell Broadcast Service (CBS)
3GPP TR 21.905-13.1.0 <a href="http://www.3gpp.org/ftp/Specs/archive/21_series/21.905/21905-d10.zip">http://www.3gpp.org/ftp/Specs/archive/21_series/21.905/21905-d10.zip</a>	Vocabulary for 3GPP Specifications

### 6.5 Documentation Conventions

The following typographic conventions are used in this document.

General Conventions	
Note	Important information requiring the user's attention.
Caution	A condition or circumstance that may cause damage to the equipment or loss of data.
 Warning	A condition or circumstance that may cause personal injury.
<i>Italics</i>	Italic font style denotes <ul style="list-style-type: none"> <li>• Emphasis of an important word</li> <li>• First use of a new term</li> <li>• Title of a document.</li> </ul>
<b>Screen Name</b>	Sans serif, bold font denotes <ul style="list-style-type: none"> <li>• On-screen name of a window, dialog box or field</li> <li>• Keys on a keyboard</li> <li>• Labels printed on the equipment.</li> </ul>
Software Conventions	
Code	Regular Courier font denotes code or text displayed on-screen.
<b>Code</b>	Bold Courier font denotes commands and parameters that you enter exactly as shown. Multiple parameters are grouped in brackets [ ]. If you are to choose only one among grouped parameters, the choices are separated with a pipe: [parm1   parm2   parm3] If there is no pipe separator, you must enter each parameter: [parm1 parm2 parm3]
<i>Code</i>	Italic Courier font denotes parameters that require you to enter a value or variable. Multiple parameters are grouped in brackets [ ]. If you are to choose only one among grouped parameters, the choices are separated with a pipe: [parm1   parm2   parm3] If there is no pipe separator, you must enter a value for each parameter: [parm1 parm2 parm3]

**Revision History**

Rev.	Date	Description	
		Page	Summary
1.00	Nov.10.20	—	First release document
1.01	May.24.21		Section 1 edited.
1.02	Jun.01.21	2-7, 10-20, others	New information in sections 1.1, 1.2 and 1.5. Other minor changes.
1.03	Mar.04.22	9 30	Changed Access URL Added Certification of Compliance

---

RYZ014AAA RYZ014A Evaluation Kit User's Manual

Publication Date: Mar. 4.22

Published by: Renesas Electronics Corporation

---

# RYZ014AAA RYZ014A Evaluation Kit