

DRAWING MADE IN THIRD ANGLE PROJECTION

THIS DRAWING IS UNPUBLISHED. RELEASED FOR PUBLICATION ,19 .

© COPYRIGHT 19 BY AMP INCORPORATED. ALL INTERNATIONAL RIGHTS RESERVED.

| LOC | DIST | REVISIONS |     |                   |         |      |
|-----|------|-----------|-----|-------------------|---------|------|
|     |      | ZONE      | LTR | DESCRIPTION       | DATE    | APPD |
| G   | 14   |           |     | E EC 0720-0279-93 | 6-21-93 | BB   |

**AMP**  
WIRE RANGE  
2 AWG  
STRANDED

**METRIC**  
DIMENSIONS LISTED IN mm [ INCHES ]

1. TONGUE MATERIAL THK  $1.45 \pm 0.08$  [  $0.057 \pm 0.003$  ]  
FOR  $11.89$  [  $0.468$  ] MAX WIRE INS DIA

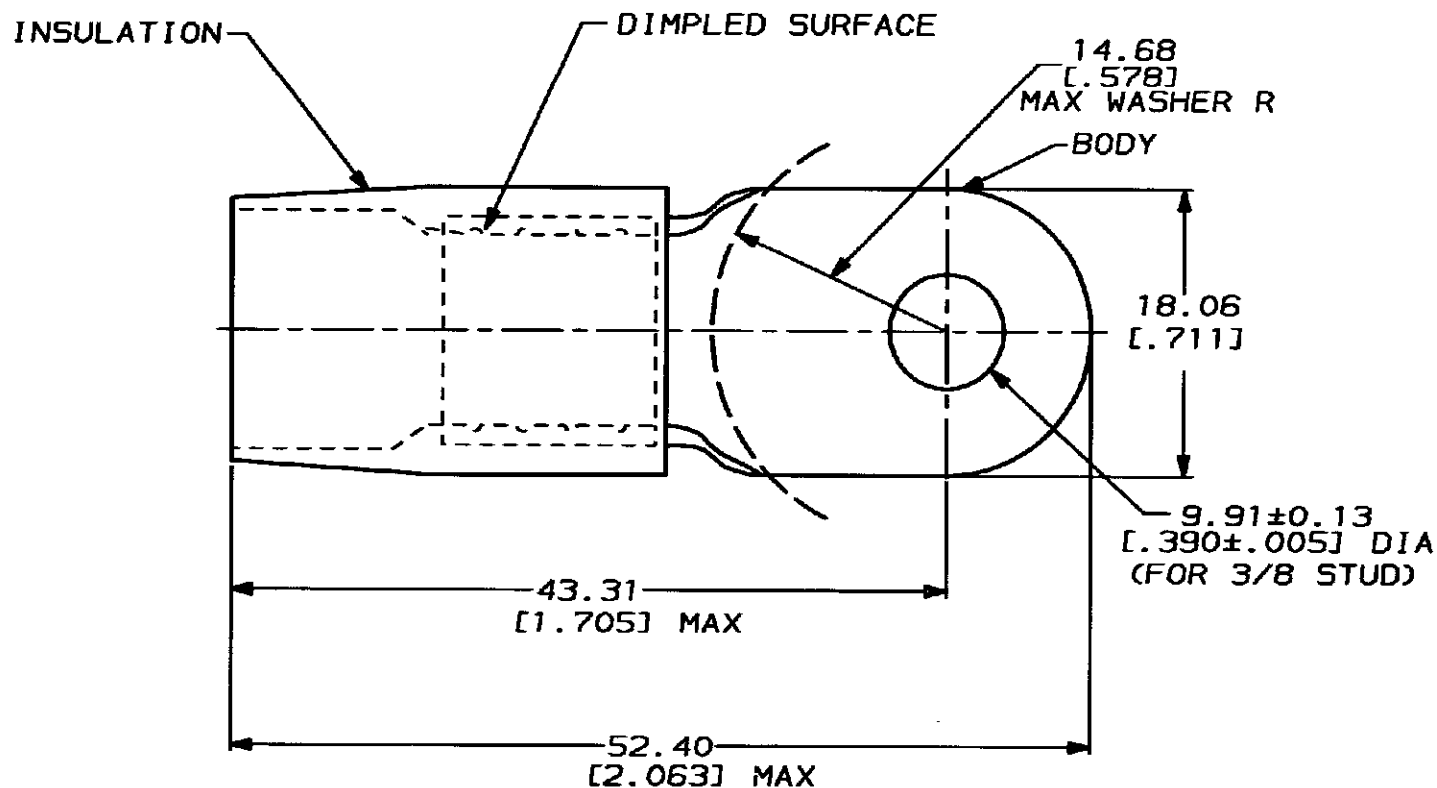

**AMP INCORPORATED**  
**CUSTOMER SERVICE SYSTEMS**

|  |  |
|--|--|
| FOR ADDITIONAL PRODUCT INFORMATION OR COPIES OF DRAWINGS AND TECHNICAL DOCUMENTS | PRODUCT INFORMATION CENTER<br>1-800-522-6752 |
| FOR APPLICATION TOOLING INFORMATION  | TOOLING ASSISTANCE CENTER<br>1-800-722-1111  |
| FOR ORDER ENTRY  | 1-800-526-5142                               |

MAX RECOMMENDED OPERATING TEMPERATURE:  
105°C

VOLTAGE RATING:  
-

CIRCULAR MIL AREA:  
26.7-42.4mm<sup>2</sup> [52,600-83,700]  
STRANDED

THIS DRAWING IS A CONTROLLED DOCUMENT FOR AMP INCORPORATED. IT IS SUBJECT TO CHANGE AND THE CONTROLLING ENGINEERING ORGANIZATION SHOULD BE CONTACTED FOR THE LATEST REVISION.

|   |                           |  |                  |
|---|---------------------------|--|------------------|
| MS25036-127<br>CLASS 2  | -                         | LOOSE PC   | 324054           |
| MILITARY P/N & CLASS  | QTY                       | PACKAGE TYPE   | PART NO          |
| DO NOT SCALE PRINT. UNLESS SPECIFIED  | OR 6-21-93<br>S.S. BOLDEN | <b>AMP</b> AMP Incorporated<br>Harrisburg, PA 17105-3608 |                  |
| TOLERANCES UNLESS OTHERWISE SPECIFIED:<br>2 PLC DEC ± 0.20 [0.008]<br>3 PLC DEC ± -<br>ANGLES ± - | CHK 6-21-93<br>R. HERSEY  | NAME   |                  |
| MATERIAL<br>COPPER PER ASTM B-152<br>NYLON (MIL-H-20693) TYPE 1<br>COLOR: RED                     | APPD 6-21-93<br>B. BARE   | TERMINAL, RING TONGUE, TERMINYL<br>WIRE SIZE: 2 AWG      |                  |
| FINISH<br>TIN PLATE PER MIL-T-10727   | APPD 6-21-93<br>R. ELLIS  | SIZE   | CAGE CODE        |
|   | PRODUCT SPEC              | <b>B</b>   | 00779            |
|   | APPLICATION SPEC          | DRAWING NO   | <b>C</b> -324054 |
|   | WEIGHT -                  | SCALE  | SHEET            |
|   |                           | NTS  | 1 OF 1           |