

Foot-switch - Ex II 2G
 Series F2-EX UN Ex II 2D

Description **F2-SU1Z/SU1Z EX UN -5M-**

Article number **6096197029**

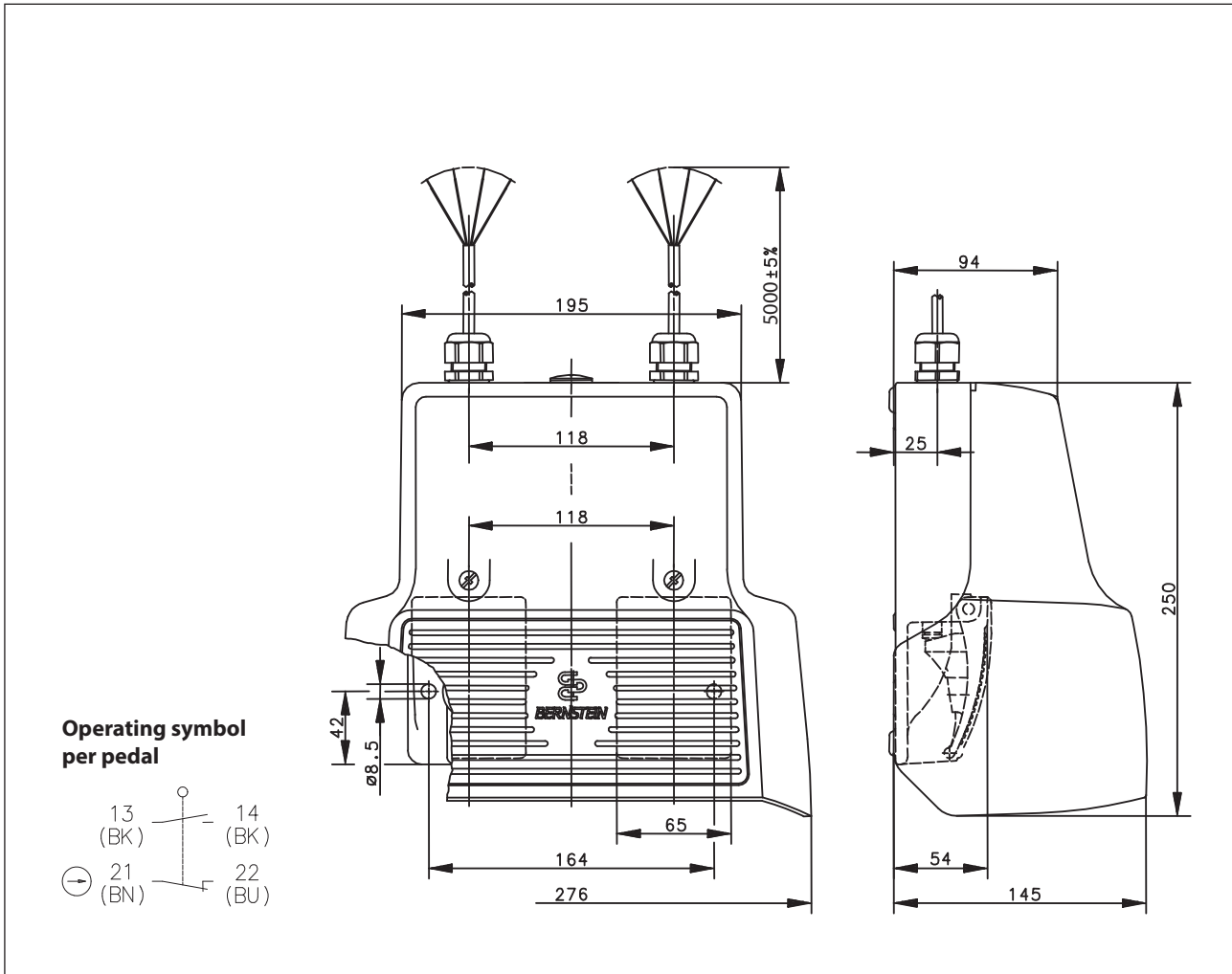



Electrical data		
Rated insulation voltage	U_i	250 V AC
Conv. thermal current	I_{the}	5 A
Rated operational voltage	U_e	230 V
Utilization category		AC 15, 240 V / 3 A; DC 13, 250 V / 0,27 A
Direct opening action	---	acc. to IEC/EN 60947-5-1, Annex K
Short-circuit protective device		Fuse 4 A gG (with safety function) Fuse 6 A gG
Safety class		II, fully insulated (see Notes)

Mechanical Data	
Enclosure	AL, die-cast
Accident protection cover	AL, die-cast
Actuator	Foot lever (AL, die-cast)
Ambient air temperature	-20 °C ... +60 °C
Maximum surface temperature	+80 °C / T6
Contact type	2 NC, 2 NO (Zb)
Operating force	≈ 10 N (pedal centre)
Mechanical life	2 x 10 ⁶ switching cycles
Mechanical switching frequency	≤ 50 / min.
Switching frequency under max. load	≤ 20 / min. (AC), ≤ 15 / min. (DC)
Assembly	2 screws M8
Connection	2 x Control cable (with wire end ferrules)
Conductor cross-sections	4 x 0,75 mm ²
Cable entrance	2 x cable gland M20 x 1,5
Weight including protective guard	≈ 3,4 kg
Installation position	Any, installed in a protected position on the underside of the enclosure
Protection type of the installed switch block	IP 66 / IP 67 acc. to IEC / EN 60529

ID for safety engineering	
B10d	4 x 10 ⁶ switching cycles

Standards	
	VDE 0660 T100, DIN EN 60947-1, IEC 60947-1
	VDE 0660 T200, DIN EN 60947-5-1, IEC 60947-5-1
	VDE 0170-1, DIN EN 60079-0, IEC 60079-0
	VDE 0170-5, DIN EN 60079-1, IEC 60079-1
	VDE 0170-15, DIN EN 60079-31, IEC 60079-31
	DIN EN ISO 13849-1

Explosion Protection	
	 II 2 G Ex d IIC T6 Gb
	 II 2 D Ex tb IIIC T80°C Db

EC-Type Examination Certificate	
Foot-switch complete	TÜV 03 ATEX 2043X
Installed switch block	TÜV 03 ATEX 2021X

BG-Type Examination Certificate	
	Installed switch block
	GS-ET-15

EU Conformity	
	acc. to explosion-protection directive 94/9/EC
	acc. to machinery directive 2006/42/EC

Notes

The switching unit must be securely installed.
The cable must be securely laid and protected against mechanical damage.
The metal enclosure of the switch must be earthed if the enclosure can be expected to develop a hazardous charge during operation.
Other cable lengths on request.