

MultiCat™ In-line Power Connector System

WIRE-TO-WIRE AND WIRE-TO-BOARD

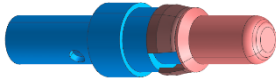

MALE CRIMP CONTACT (201845-00X0)

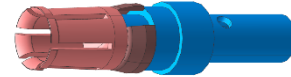

FEMALE CRIMP CONTACT (201846-00X0)

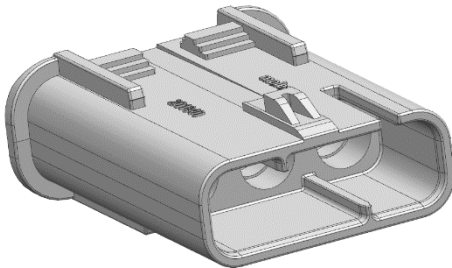

PLUG HOUSING (201840-00XX)

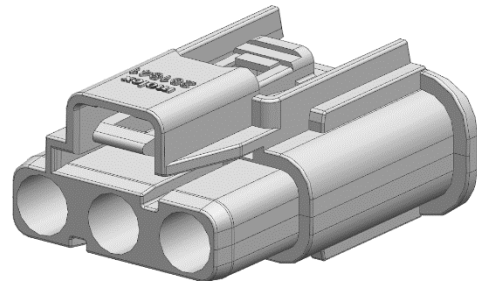

RECEPTACLE HOUSING (201841-00XX)

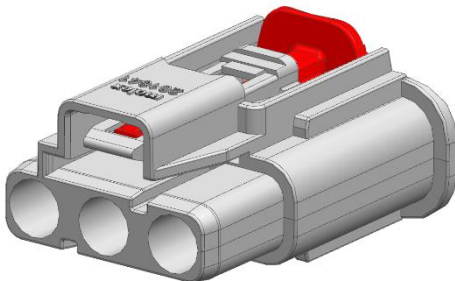

RECEPTACLE HOUSING WITH CPA (201841-01XX)

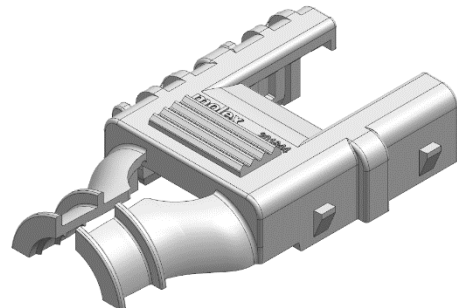

PLUG / RECEPTACLE BACKSHELL (201844-0XXX)

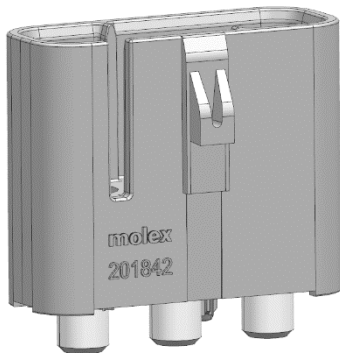

VERTICAL HEADER (201842-10XX)

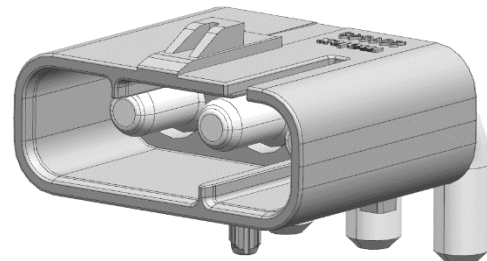

RIGHT ANGLE HEADER (201843-10XX)

REVISION: A6	ECR/ECN INFORMATION: ECM: 120127 DATE: 2017 / 08 / 01	TITLE: PRODUCT SPECIFICATION FOR MULTICAT™ IN-LINE POWER CONNECTOR SYSTEM (WtW/WtB)	SHEET No. 1 of 15
DOCUMENT NUMBER: 2018400000-PS	CREATED / REVISED BY: CD	CHECKED BY: NCSR	APPROVED BY: KPRASAD

1.0 SCOPE

This Product Specification covers the 7.40 mm (.291 inch) centerline (pitch) connector series terminated with 8 to 18 AWG wire using crimp technology with gold plating.

This Product Specification also covers the 7.40 mm (.291 inch) centerline (pitch) printed circuit board (PCB) connector series with gold plating.

2.0 PRODUCT DESCRIPTION

2.1 PRODUCT NAME AND SERIES NUMBER(S)

MULTICAT PLUG HOUSING 1X3 KEY A BLACK MULTICAT PLUG HOUSING 1X3 KEY B GRAY MULTICAT PLUG HOUSING 1X4 KEY A BLACK MULTICAT PLUG HOUSING 1X4 KEY B GRAY	201840
MULTICAT RECEPTACLE HOUSING 1X3 KEY A BLACK MULTICAT RECEPTACLE HOUSING 1X3 KEY B GRAY MULTICAT RECEPTACLE HOUSING 1X4 KEY A BLACK MULTICAT RECEPTACLE HOUSING 1X4 KEY B GRAY MULTICAT RECEPTACLE HOUSING WITH CPA 1X3 KEY A BLACK MULTICAT RECEPTACLE HOUSING WITH CPA 1X3 KEY B GRAY MULTICAT RECEPTACLE HOUSING WITH CPA 1X4 KEY A BLACK MULTICAT RECEPTACLE HOUSING WITH CPA 1X4 KEY B GRAY	201841
MULTICAT VERTICAL HEADER 1X3 KEY A BLACK MULTICAT VERTICAL HEADER 1X3 KEY B GRAY MULTICAT VERTICAL HEADER 1X4 KEY A BLACK MULTICAT VERTICAL HEADER 1X4 KEY B GRAY	201842
MULTICAT RIGHT ANGLE HEADER 1X3 KEY A BLACK MULTICAT RIGHT ANGLE HEADER 1X3 KEY B GRAY MULTICAT RIGHT ANGLE HEADER 1X4 KEY A BLACK MULTICAT RIGHT ANGLE HEADER 1X4 KEY B GRAY	201843
MULTICAT BACKSHELL 1X3 BLACK 8-10 AWG MULTICAT BACKSHELL 1X3 GRAY 8-10 AWG MULTICAT BACKSHELL 1X3 BLACK 12-18 AWG MULTICAT BACKSHELL 1X3 GRAY 12-18 AWG MULTICAT BACKSHELL 1X4 BLACK 8-10 AWG MULTICAT BACKSHELL 1X4 GRAY 8-10 AWG MULTICAT BACKSHELL 1X4 BLACK 12-18 AWG MULTICAT BACKSHELL 1X4 GRAY 12-18 AWG	201844
MULTICAT MALE CRIMP CONTACT 8-10 AWG MULTICAT MALE CRIMP CONTACT 12-14 AWG MULTICAT MALE CRIMP CONTACT 16-18 AWG	201845
MULTICAT FEMALE CRIMP CONTACT 8-10 AWG MULTICAT FEMALE CRIMP CONTACT 12-14 AWG MULTICAT FEMALE CRIMP CONTACT 16-18 AWG	201846

2.2 DIMENSIONS, MATERIALS, PLATINGS AND MARKINGS

Refer Sales Drawings 2018400000-SD, 2018410000-SD, 2018420000-SD, 2018430000-SD, 2018440000-SD, 2018450010PSD, 2018450020PSD, 2018450040PSD, 2018460010PSD, 2018460020PSD, 2018460040PSD

REVISION: A6	ECR/ECN INFORMATION: ECM: 120127 DATE: 2017 / 08 / 01	TITLE: PRODUCT SPECIFICATION FOR MULTICAT™ IN-LINE POWER CONNECTOR SYSTEM (WtW/WtB)	SHEET No. 2 of 15
DOCUMENT NUMBER: 2018400000-PS	CREATED / REVISED BY: CD	CHECKED BY: NCSR	APPROVED BY: KPRASAD

2.3 SAFETY AGENCY APPROVALS

UL File Number: E29179

3.0 APPLICABLE DOCUMENTS AND SPECIFICATIONS

Application Specification 2018400000-AS

Test Summary 2018400000-TS

Refer section 8.0 for Environmental Test Sequences

4.0 RATINGS

4.1 VOLTAGE

1200 Volts AC/DC

4.2 APPLICABLE WIRES

AWG	Nominal Insulation Diameter
8	5.84 mm
10	4.03 mm
12	3.40 mm
14	2.92 mm
16	2.59 mm
18	2.36 mm

4.3 CURRENT

Rating shown below represent maximum current carrying capacity of a fully loaded connector with all circuits powered using UL1199 stranded wire. Ratings are based on a 30 °C maximum temperature rise limit over ambient (see section 5.1.4 for specification) without derating.

Current is dependent on connector size, ambient temperature, printed circuit board characteristics and related factors. Actual current rating is application dependent and should be evaluated for each use.

Note: PCB trace design can greatly affect temperature rise results in Wire-to-Board applications.

	3 CIRCUIT		4 CIRCUIT	
	Wire-to-Wire	Wire-to-Board	Wire-to-Wire	Wire-to-Board
8 AWG	40 A	34 A	38 A	34 A
10 AWG	32 A [#]	28 A [#]	31 A [#]	28 A [#]
12 AWG	26 A	24 A	26 A	24 A
14 AWG	20 A [#]	20 A [#]	21 A [#]	20 A [#]
16 AWG	16 A [#]	16 A [#]	17 A [#]	16 A [#]
18 AWG	14 A	14 A	14 A	14 A

[#]Interpolated

REVISION:	ECR/ECN INFORMATION:	TITLE:	SHEET No.
A6	ECM: 120127 DATE: 2017 / 08 / 01	PRODUCT SPECIFICATION FOR MULTICAT™ IN-LINE POWER CONNECTOR SYSTEM (WtW/WtB)	3 of 15
DOCUMENT NUMBER:	CREATED / REVISED BY:	CHECKED BY:	APPROVED BY:
2018400000-PS	CD	NCSR	KPRASAD

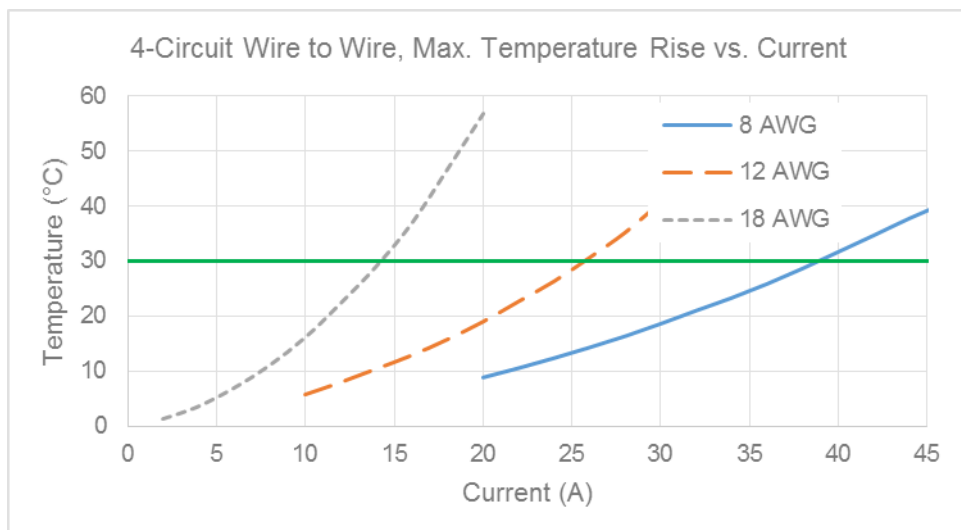
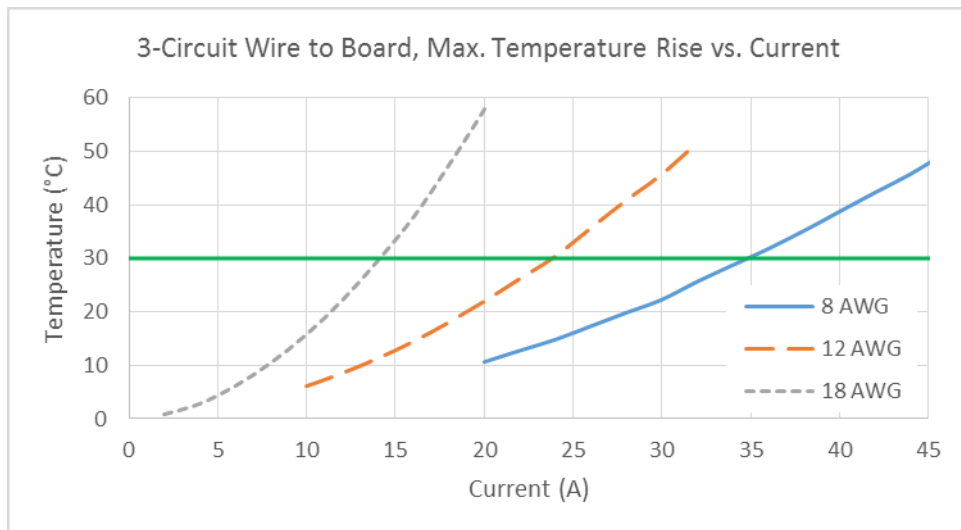
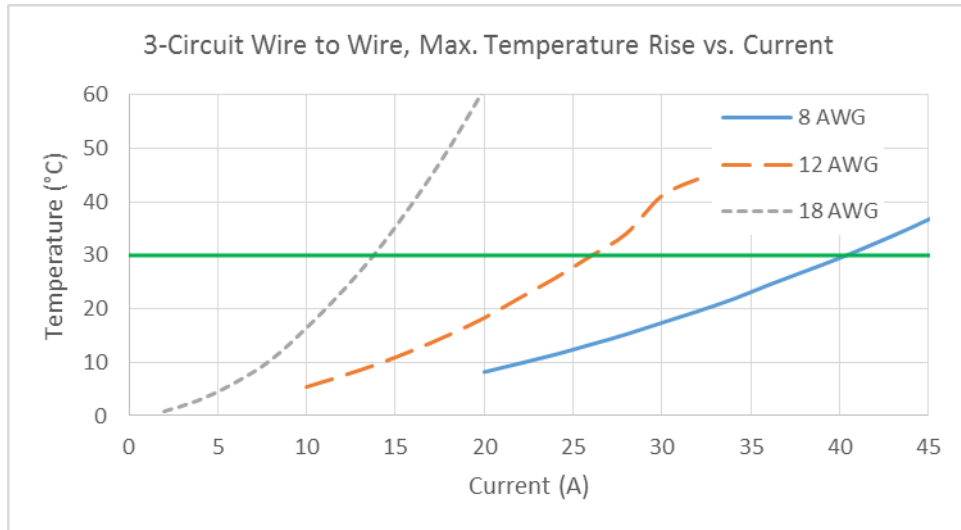

REVISION: A6	ECR/ECN INFORMATION: ECM: 120127 DATE: 2017 / 08 / 01	TITLE: PRODUCT SPECIFICATION FOR MULTICAT™ IN-LINE POWER CONNECTOR SYSTEM (WtW/WtB)	SHEET No. 4 of 15
DOCUMENT NUMBER: 2018400000-PS	CREATED / REVISED BY: CD	CHECKED BY: NCSR	APPROVED BY: KPRASAD

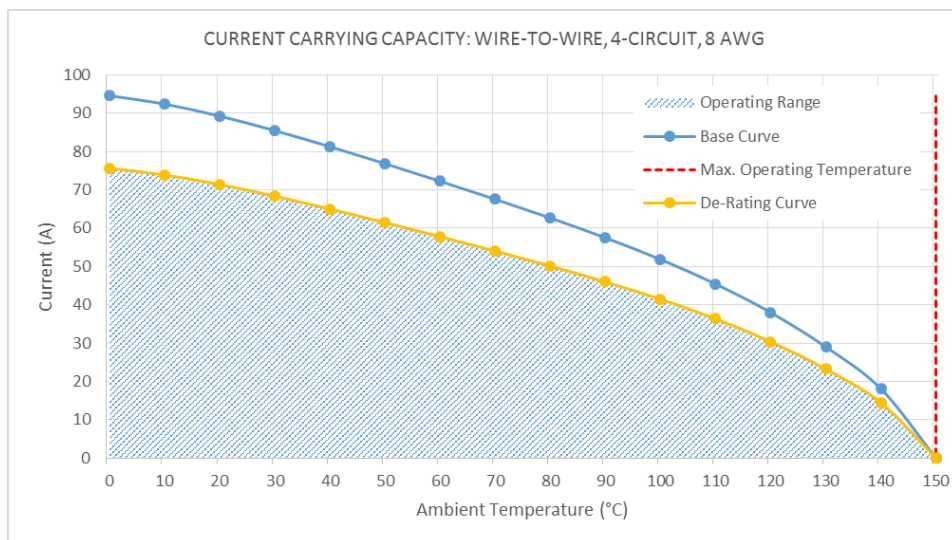
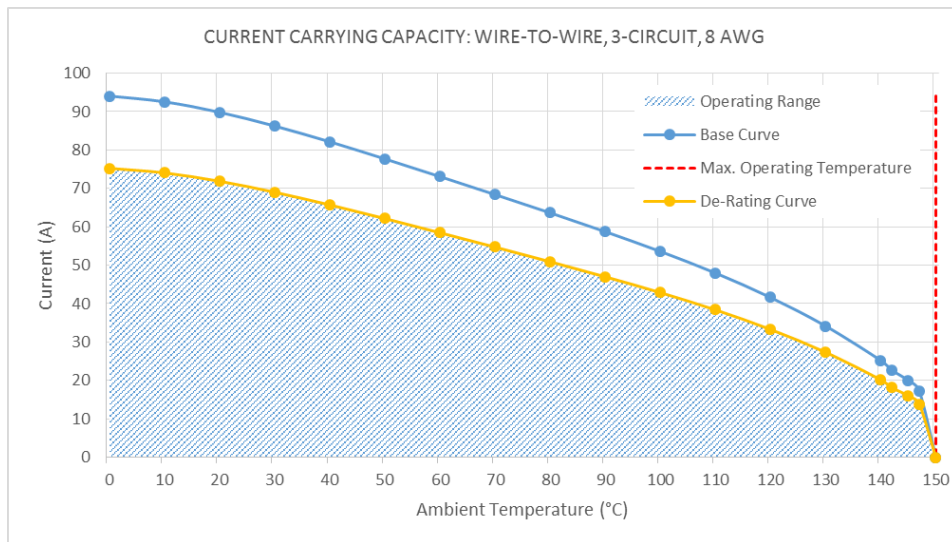
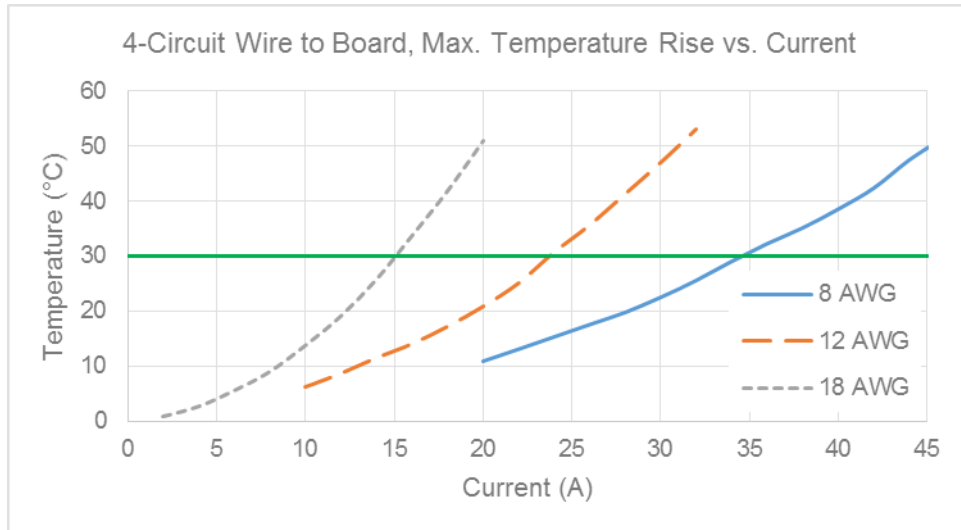

REVISION: A6	ECR/ECN INFORMATION: ECM: 120127 DATE: 2017 / 08 / 01	TITLE: PRODUCT SPECIFICATION FOR MULTICAT™ IN-LINE POWER CONNECTOR SYSTEM (WtW/WtB)	SHEET No. 5 of 15
DOCUMENT NUMBER: 2018400000-PS	CREATED / REVISED BY: CD	CHECKED BY: NCSR	APPROVED BY: KPRASAD

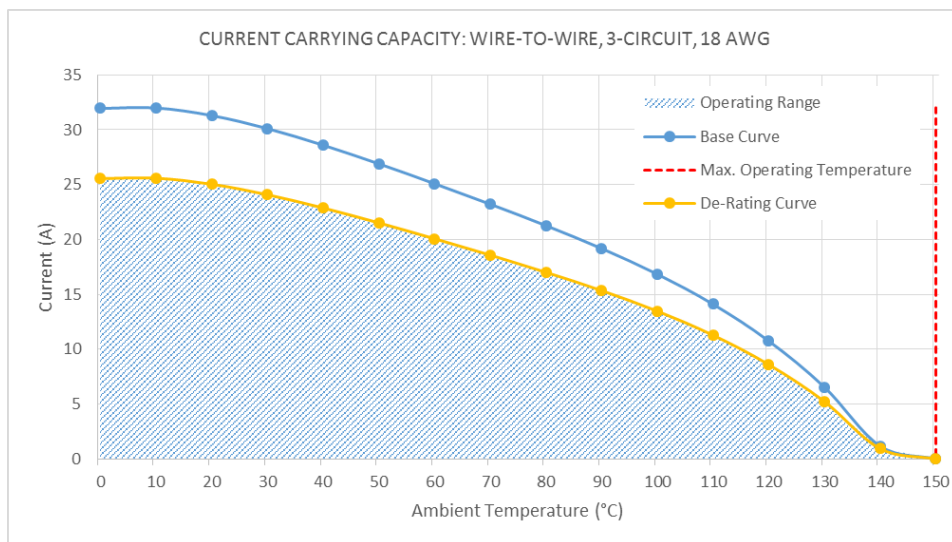
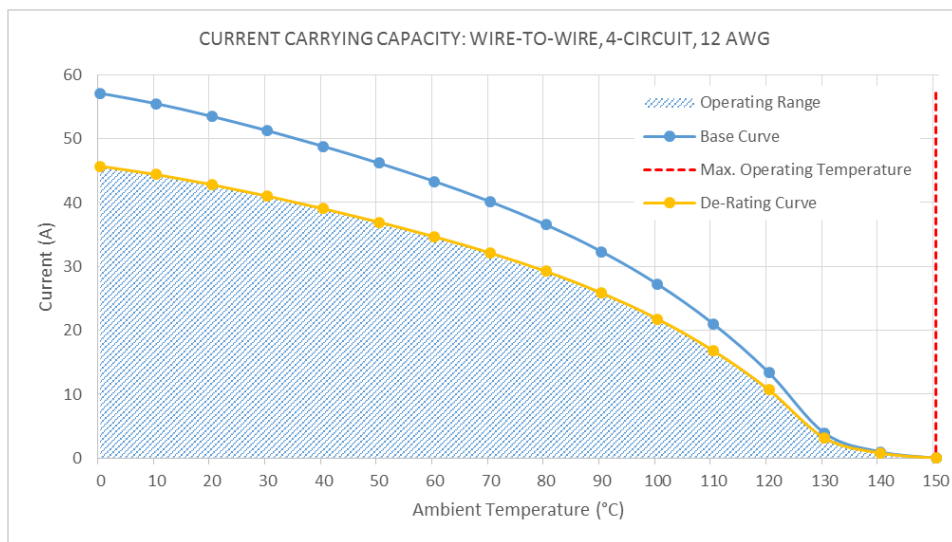
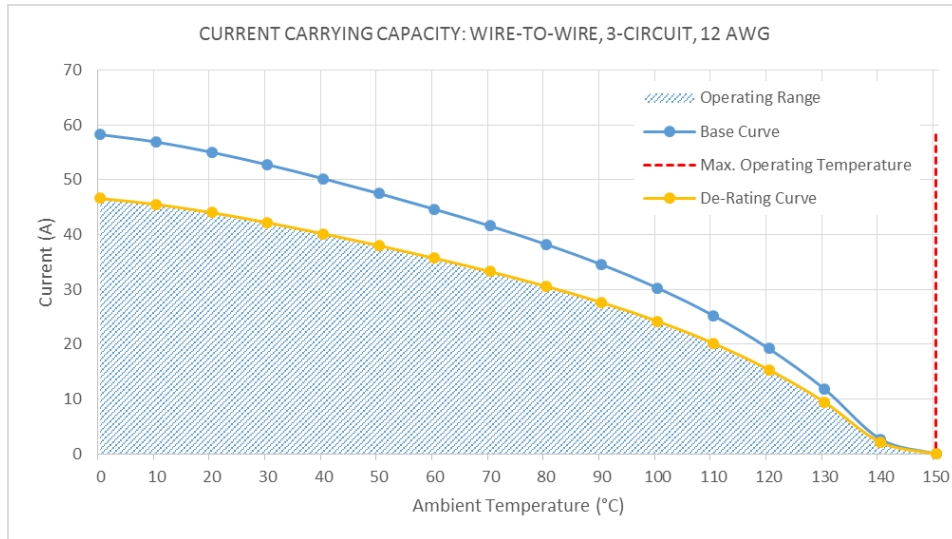

REVISION: A6	ECR/ECN INFORMATION: <u>ECM: 120127</u> <u>DATE: 2017 / 08 / 01</u>	TITLE: PRODUCT SPECIFICATION FOR MULTICAT™ IN-LINE POWER CONNECTOR SYSTEM (WtW/WtB)	SHEET No. 6 of 15
DOCUMENT NUMBER: 2018400000-PS	CREATED / REVISED BY: CD	CHECKED BY: NCSR	APPROVED BY: KPRASAD

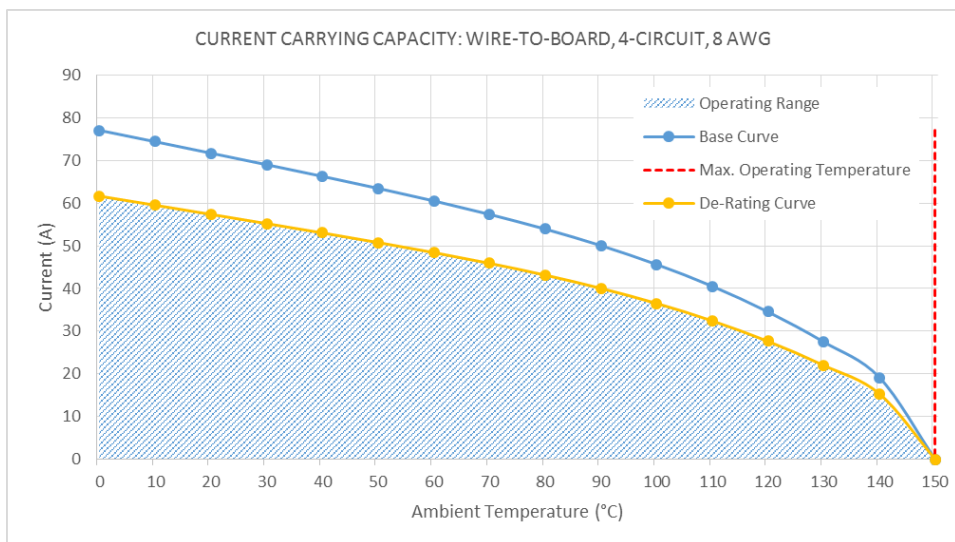
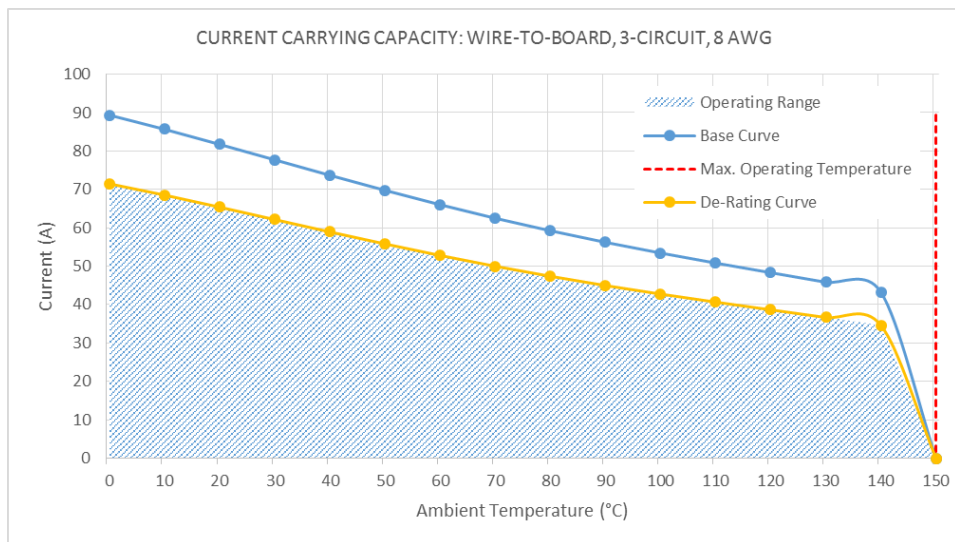
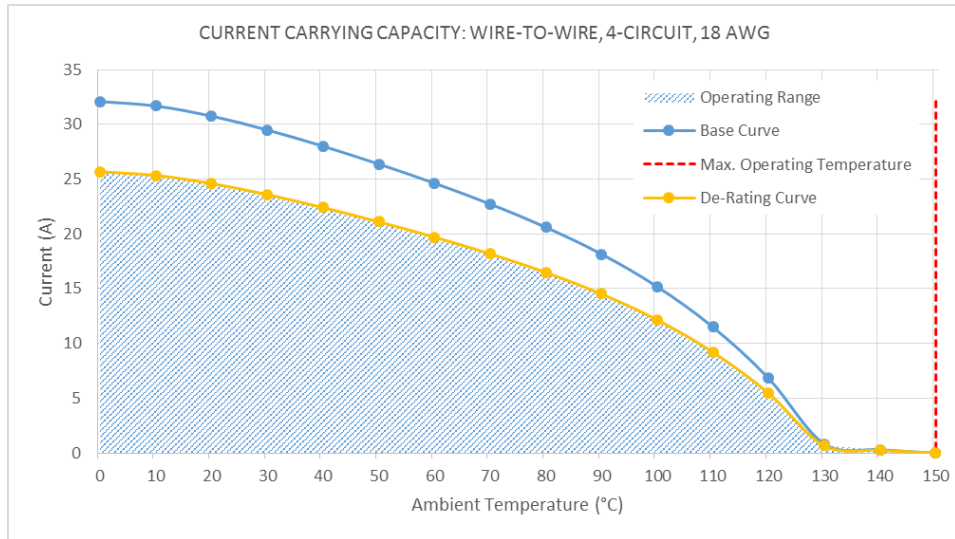

REVISION: A6	ECR/ECN INFORMATION: ECM: 120127 DATE: 2017 / 08 / 01	TITLE: PRODUCT SPECIFICATION FOR MULTICAT™ IN-LINE POWER CONNECTOR SYSTEM (WtW/WtB)	SHEET No. 7 of 15
DOCUMENT NUMBER: 2018400000-PS	CREATED / REVISED BY: CD	CHECKED BY: NCSR	APPROVED BY: KPRASAD

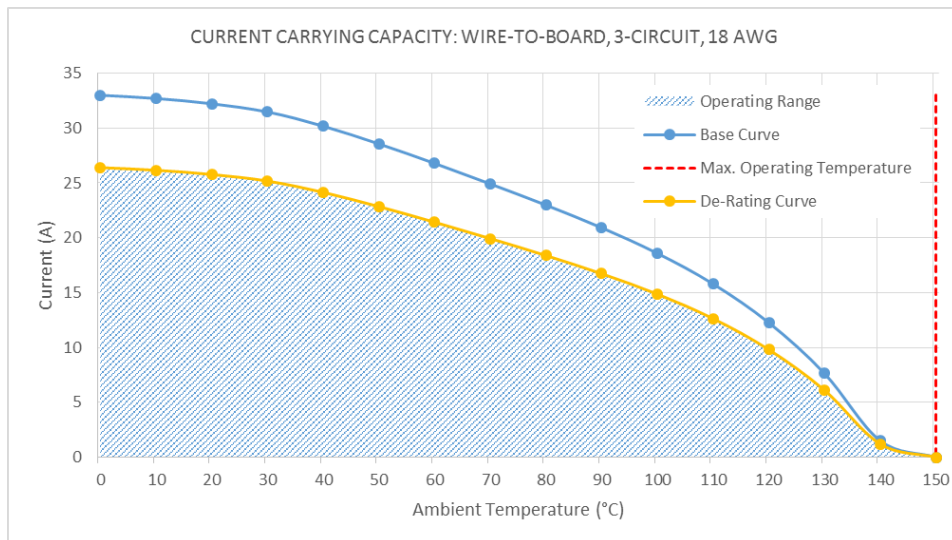
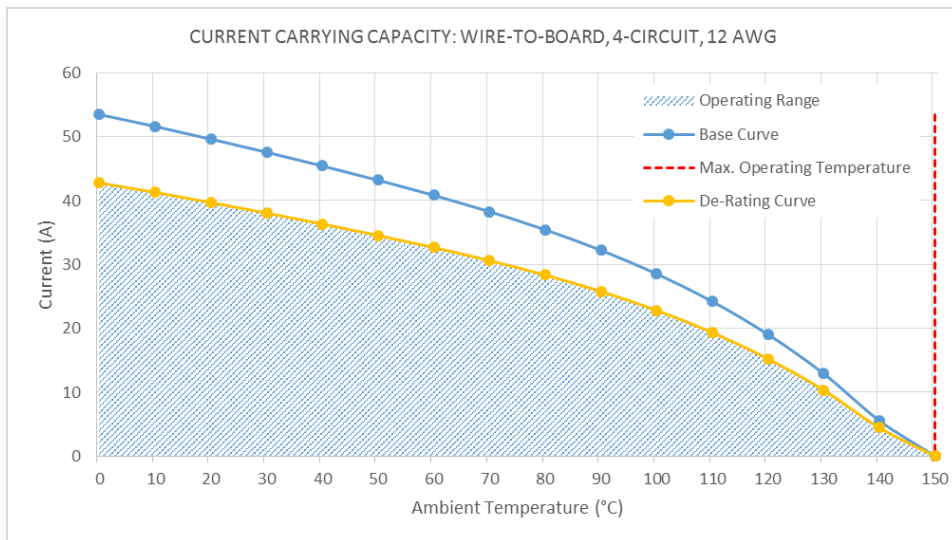
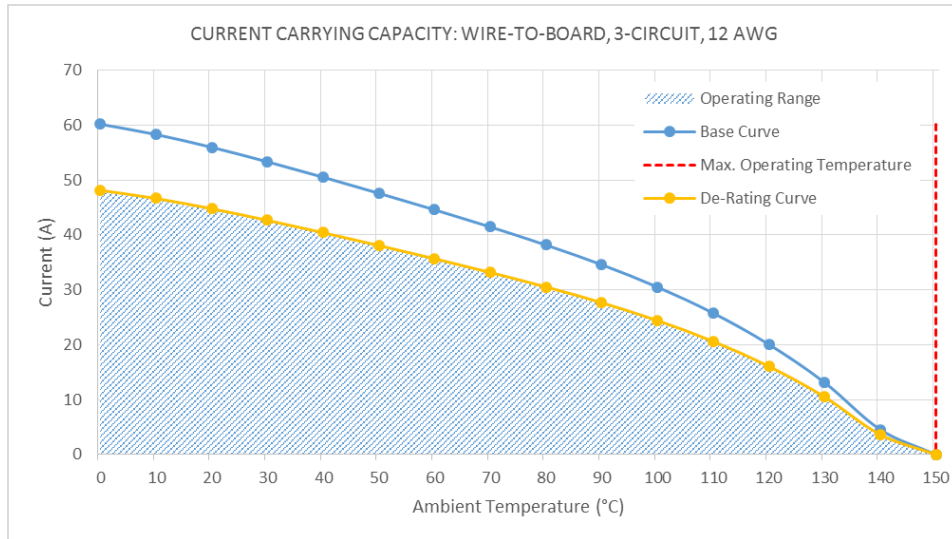

REVISION: A6	ECR/ECN INFORMATION: <u>ECM: 120127</u> <u>DATE: 2017 / 08 / 01</u>	TITLE: PRODUCT SPECIFICATION FOR MULTICAT™ IN-LINE POWER CONNECTOR SYSTEM (WtW/WtB)	SHEET No. 8 of 15
DOCUMENT NUMBER: 2018400000-PS	CREATED / REVISED BY: CD	CHECKED BY: NCSR	APPROVED BY: KPRASAD

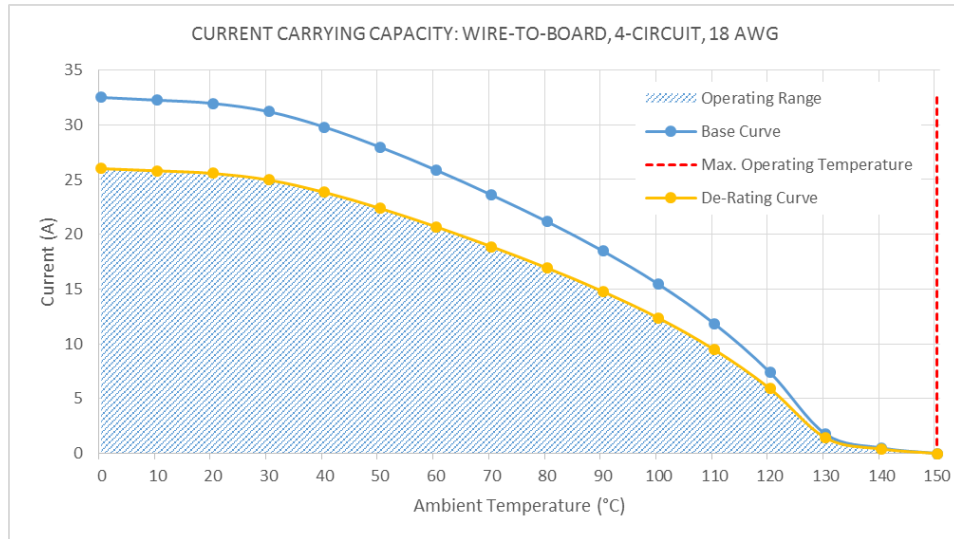

4.4 TEMPERATURE

Operating: -40 °C to +150 °C

REVISION: A6	ECR/ECN INFORMATION: ECM: 120127 DATE: 2017 / 08 / 01	TITLE: PRODUCT SPECIFICATION FOR MULTICAT™ IN-LINE POWER CONNECTOR SYSTEM (WtW/WtB)	SHEET No. 9 of 15
DOCUMENT NUMBER: 2018400000-PS	CREATED / REVISED BY: CD	CHECKED BY: NCSR	APPROVED BY: KPRASAD

5.0 PERFORMANCE

5.1 ELECTRICAL REQUIREMENTS

ITEM	DESCRIPTION	TEST CONDITION	REQUIREMENT
5.1.1	Contact Resistance (Low Level)	Mate connectors: apply a maximum voltage of 20 mV and a current of 100 mA . EIA-364-23B	1 mΩ MAXIMUM [initial]
5.1.2	Insulation Resistance	Mate connectors: apply a voltage of 500 VDC between adjacent terminals and between terminals to ground. EIA-364-21D	1000 MΩ MINIMUM
5.1.3	Dielectric Withstanding Voltage	Mate connectors: apply a voltage of 3400 VAC for 1 minute between adjacent terminals and between terminals to ground. EIA-364-20E, Method B	No breakdown; current leakage < 5 mA
5.1.4	Temperature Rise (Current Profiling)	Mate connectors: measure the temperature rise at the rated current. EIA-364-70B, Method 2	Temperature rise: +30 °C MAXIMUM [over ambient]
5.1.5	Temperature Rise (18-day Stability)	Mate connectors: measure the temperature rise at the rated current after: 96 hours (Steady state) 240 hours (Current cycling) 45 minutes ON and 15 minutes OFF per hour 96 hours (Steady state) Steady state per EIA-364-70B, Method 2. Current cycling per EIA-364-55A, Test Condition A, Test Method 4.	Temperature rise: +30 °C MAXIMUM [over ambient]

5.2 MECHANICAL REQUIREMENTS

ITEM	DESCRIPTION	TEST CONDITION	REQUIREMENT
5.2.1	Connector Mate and Unmate Forces [Initial cycle] <i>Latch disabled</i> (See section 6.0 for additional information)	Mate and unmate connector (male to female) at a rate of 25 ± 6 mm (1 ± ¼ inch) per minute. EIA-364-13E, Method A	20 N (4.49 lbf) MAXIMUM mate force per circuit and 5 N (1.12 lbf) MINIMUM unmate force per circuit
5.2.2	Terminal Insertion Force (into Housing)	Apply an axial insertion force on the terminal at a rate of 25 ± 6 mm (1 ± ¼ inch) . EIA-364-05B	40 N (8.99 lbf) MAXIMUM insertion force

REVISION: A6	ECR/ECN INFORMATION: ECM: 120127 DATE: 2017 / 08 / 01	TITLE: PRODUCT SPECIFICATION FOR MULTICAT™ IN-LINE POWER CONNECTOR SYSTEM (WtW/WtB)	SHEET No. 10 of 15
DOCUMENT NUMBER: 2018400000-PS	CREATED / REVISED BY: CD	CHECKED BY: NCSR	APPROVED BY: KPRASAD

5.2 MECHANICAL REQUIREMENTS (continued)

ITEM	DESCRIPTION	TEST CONDITION	REQUIREMENT	
5.2.3	Terminal Retention Force (in Housing)	Axial pullout force on the terminal in the housing at a rate of 25 ± 6 mm ($1 \pm \frac{1}{4}$ inch) per minute. EIA-364-29C, Method C	175 N (39.34 lbf) MINIMUM retention force	
			after High Temperature exposure (see item 5.3.4) 150 N (33.72 lbf) MINIMUM retention force	
5.2.4	Housing Locking Mechanism Strength (after 500 Cycles)	Exert an axial force at a rate of 13 mm per minute (0.5 inch per minute) to separate the housing halves. EIA-364-98	200 N (44.96 lbf) MINIMUM retention force	
5.2.5	Wire Pullout Force (Axial)	Apply an axial pullout force on the wire at a rate of 25 ± 6 mm ($1 \pm \frac{1}{4}$ inch). EIA-364-08B	AWG	MINIMUM pullout force
			8	450 N (101.2 lbf)
			10	355 N (79.8 lbf)
			12	275 N (61.8 lbf)
			14	200 N (44.9 lbf)
			16	135 N (30.3 lbf)
5.2.6	Connector Audible Feedback	The connector lock must provide audible feedback during connector mating. USCAR-2, Rev 6, Paragraph 5.4.7	7 dB over Ambient	
5.2.7	Durability EIA-364-1000 Test Group 7 (See section 8.0)	Mate and unmate connectors up to 500 cycles at a rate of 300 cycles per hour. Actuate housing latch mechanism for each cycle. EIA-364-09	5 mΩ MAXIMUM (change from initial) & Dielectric Withstanding Voltage: No breakdown; current leakage < 5 mA & Visual: No Damage	
5.2.8	Vibration (Random)	Mate connectors and vibrate per EIA 364-28, test condition VII. (Acceleration 3.1 g)	5 mΩ MAXIMUM (change from initial) & Discontinuity < 1 microsecond	
	Shock (Mechanical) EIA-364-1000 Test Group 3 (See section 8.0)	Mate connectors and shock at 50 g's with $\frac{1}{2}$ sine wave (11 milliseconds) shocks in the $\pm X$, $\pm Y$, $\pm Z$ axes (18 shocks total). EIA-364-27C, Test Condition A		

REVISION:	ECR/ECN INFORMATION:	TITLE:	SHEET No.
A6	ECM: 120127 DATE: 2017 / 08 / 01	PRODUCT SPECIFICATION FOR MULTICAT™ IN-LINE POWER CONNECTOR SYSTEM (WtW/WtB)	11 of 15
DOCUMENT NUMBER:	CREATED / REVISED BY:	CHECKED BY:	APPROVED BY:
2018400000-PS	CD	NCSR	KPRASAD

5.2 MECHANICAL REQUIREMENTS (continued)

ITEM	DESCRIPTION	TEST CONDITION	REQUIREMENT
5.2.9	Connector Position Assurance (CPA) Insertion Force	The force to insert the CPA from the preload (as shipped) position to the final position at a rate of 50 ± 6 mm (2 ± ¼ inch) per minute.	25 N (5.62 lbf) MAXIMUM insertion force
5.2.10	Connector Position Assurance (CPA) Extraction Force	The force to extract the CPA from the final position to the preload position at a rate of 50 ± 6 mm (2 ± ¼ inch) per minute.	40 N (8.99 lbf) MAXIMUM extraction force
5.2.11	Backshell Latch retention	The force to separate the backshell halves at 25.4 mm/min	200 N (44.96 lbf) MINIMUM retention force
5.2.12	Backshell Latch Insertion	Mate the backshell halves at 25.4 mm/min	20 N (4.49 lbf) MAXIMUM insertion force

5.3 ENVIRONMENTAL REQUIREMENTS

ITEM	DESCRIPTION	TEST CONDITION	REQUIREMENT
5.3.1	Shock (Thermal) EIA-364-1000 Test Group 2A & 2B (See section 8.0)	Mate connectors; expose to 5 cycles of: <u>Temperature °C</u> <u>Duration (Minutes)</u> -40 +0/-3 30 +25 ±10 5 MAXIMUM +150 +3/-0 30 +25 ±10 5 MAXIMUM EIA-364-32D, Test Condition 4	5 mΩ MAXIMUM (change from initial) & Visual: No Damage
5.3.2	Cyclic Temperature & Humidity EIA-364-1000 Test Group 2A & 2B (See section 8.0)	Mate connectors: cycle per EIA-364-31: 24 cycles at temperature 25 ± 3 °C at 80 ± 5% relative humidity and 65 ± 3 °C at 50 ± 5% relative humidity; dwell time of 1.0 hour; ramp time of 0.5 hours.	5 mΩ MAXIMUM (change from initial) & Dielectric Withstanding Voltage: No Breakdown at 500 VAC & Insulation Resistance: 1000 Megohms MINIMUM & Visual: No Damage
5.3.3	Corrosive Atmosphere: Mixed Flow Gas (MFG) EIA-364-1000 Test Group 4 (See section 8.0)	Mate connectors: Test per EIA-364-65, Class 2A	5 mΩ MAXIMUM (change from initial) & Visual: No Damage

REVISION: A6	ECR/ECN INFORMATION: ECM: 120127 DATE: 2017 / 08 / 01	TITLE: PRODUCT SPECIFICATION FOR MULTICAT™ IN-LINE POWER CONNECTOR SYSTEM (WtW/WtB)	SHEET No. 12 of 15
DOCUMENT NUMBER: 2018400000-PS	CREATED / REVISED BY: CD	CHECKED BY: NCSR	APPROVED BY: KPRASAD

5.3 ENVIRONMENTAL REQUIREMENTS (continued)

ITEM	DESCRIPTION	TEST CONDITION	REQUIREMENT
5.3.4	High Temperature Exposure (See section 8.0)	Mate connectors per durability and expose to 1008 hours at 150 ± 2 °C USCAR-2, Class T4	5 mΩ MAXIMUM (change from initial) Visual: No Damage
5.3.5	Solderability	Per SMES-152	Solder coverage: 95% MINIMUM (per SMES-152)
5.3.6	Solder Resistance	Dip connector terminal tails in solder: Solder Duration: 10 ± 0.5 seconds; Solder Temperature: 245 ± 5 °C	Visual: No Damage to insulator material

6.0 SUPPLEMENTARY INFORMATION

Connector mate/unmate [Item 5.2.1]

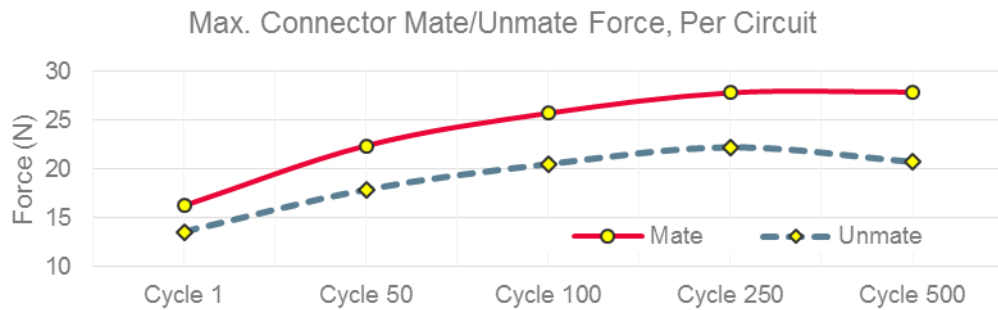

7.0 PACKAGING

Parts shall be packaged to protect against damage during handling, transit and storage.

REVISION: A6	ECR/ECN INFORMATION: ECM: 120127 DATE: 2017 / 08 / 01	TITLE: PRODUCT SPECIFICATION FOR MULTICAT™ IN-LINE POWER CONNECTOR SYSTEM (WtW/WtB)	SHEET No. 13 of 15
DOCUMENT NUMBER: 2018400000-PS	CREATED / REVISED BY: CD	CHECKED BY: NCSR	APPROVED BY: KPRASAD

8.0 TEST SEQUENCES

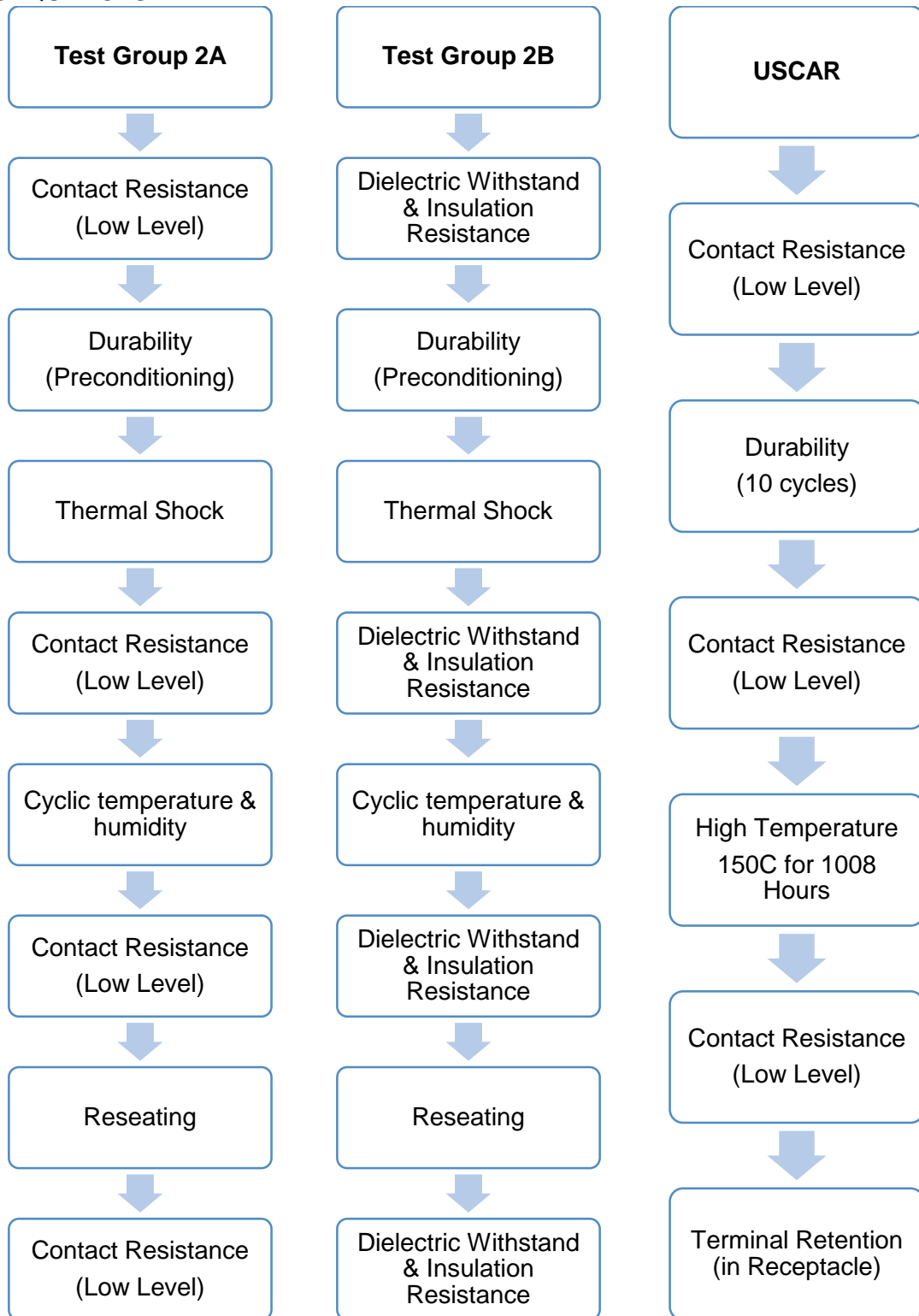

REVISION:	ECR/ECN INFORMATION:	TITLE:	PRODUCT SPECIFICATION FOR MULTICAT™ IN-LINE POWER CONNECTOR SYSTEM (WtW/WtB)		SHEET No.
A6	ECM: 120127 DATE: 2017 / 08 / 01				14 of 15
DOCUMENT NUMBER:	CREATED / REVISED BY:	CHECKED BY:	APPROVED BY:		
2018400000-PS	CD	NCSR	KPRASAD		

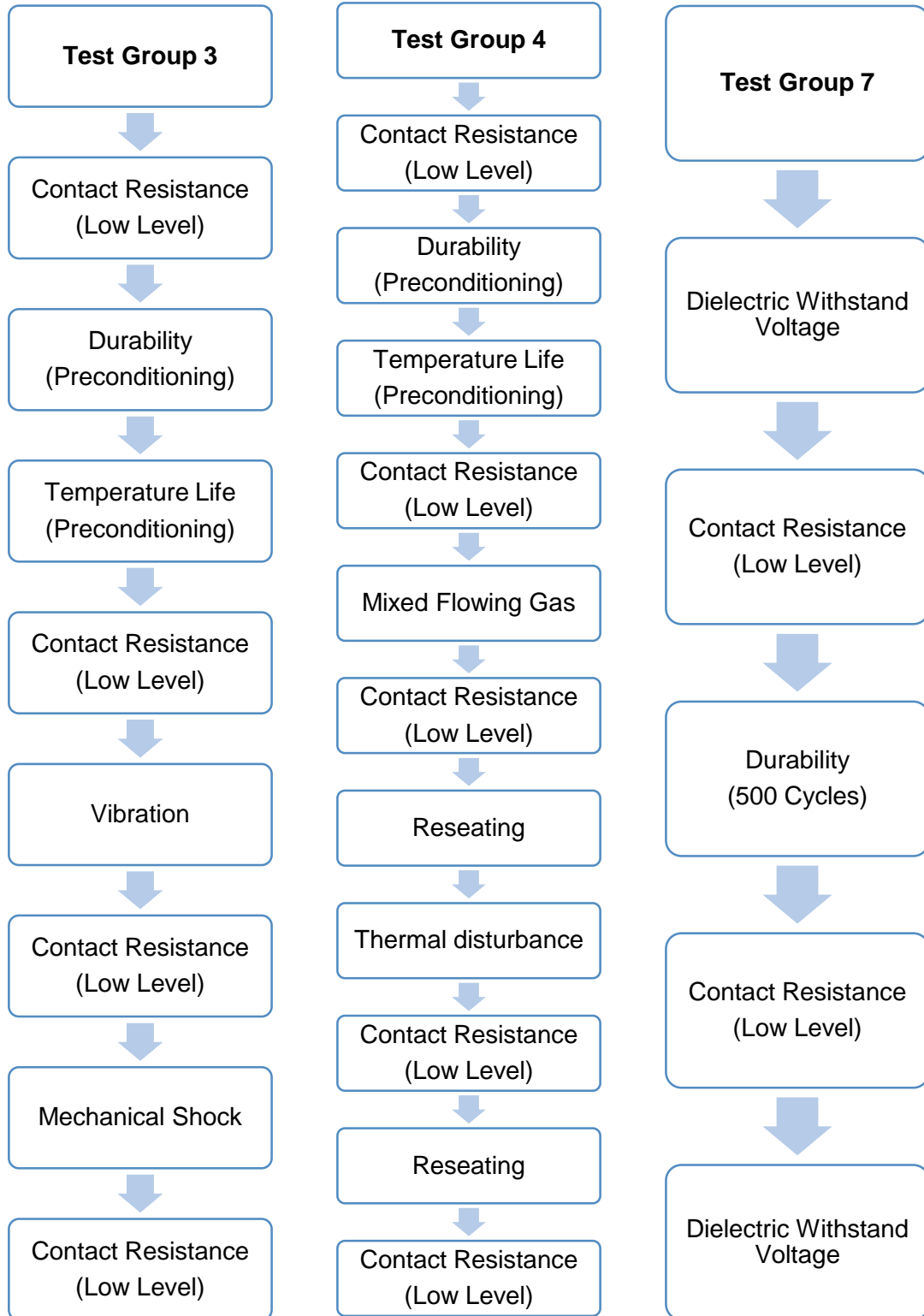

REVISION: A6	ECR/ECN INFORMATION: ECM: 120127 DATE: 2017 / 08 / 01	TITLE: PRODUCT SPECIFICATION FOR MULTICAT™ IN-LINE POWER CONNECTOR SYSTEM (WtW/WtB)	SHEET No. 15 of 15
DOCUMENT NUMBER: 2018400000-PS	CREATED / REVISED BY: CD	CHECKED BY: NCSR	APPROVED BY: KPRASAD