

### FEATURES

**USB connectivity to host PC**

**External connectivity to DSP/MCU for digital audio signals**  
(available through general-purpose 2.54 mm pitch connector)

**4 audio jacks: stereo line input, mono microphone input, stereo line output, and stereo headphone output**

**Multiple test points across the board for monitoring signals**  
**Master/slave mode selectivity**

### GENERAL DESCRIPTION

The SSM2603 is a low power, high quality stereo audio codec for portable digital audio applications with one set of stereo programmable gain amplifier (PGA) line inputs and one monaural microphone input. The board can operate as a master or slave and supports various clock frequencies. The SSM2603 software-programmable stereo output options provide many application possibilities because the device can be used as a headphone driver or as a speaker driver. Its volume control functions provide a large range of gain control of the audio signal. Included in this data sheet is a detailed setup and user guide for the SSM2603 evaluation board hardware and software. Read the Evaluation Board Quick Setup section to ensure that proper communi-

cation is established from the host PC to the SSM2603 evaluation board.

This data sheet describes how to configure and use the SSM2603 evaluation board. It is recommended that the SSM2603 evaluation board data sheet be read in conjunction with the [SSM2603](#) data sheet, which provides more detailed information about the specifications, internal block diagrams, and application guidance for the codec IC.

### EVALUATION BOARD DESCRIPTION

The SSM2603 evaluation board carries a complete application circuit for the SSM2603. The board features a USB connection to a host PC. This serves as the power supply, digital audio data, and control/status data link, making it a plug-and-play USB audio device that can communicate with the software under the Microsoft® Windows® operating system. The board also has a general-purpose 2.54 mm pitch connector to connect to an external DSP/MCU for digital audio signals.

Figure 1 shows the top view of the PCB. Figure 2 shows the bottom view of the board. The complete schematic of the board is illustrated in Figure 23 to Figure 28. Figure 29 and Figure 30 show the top layer layout and the bottom layer layout, respectively, of the PCB. The bill of materials is shown in Table 1.

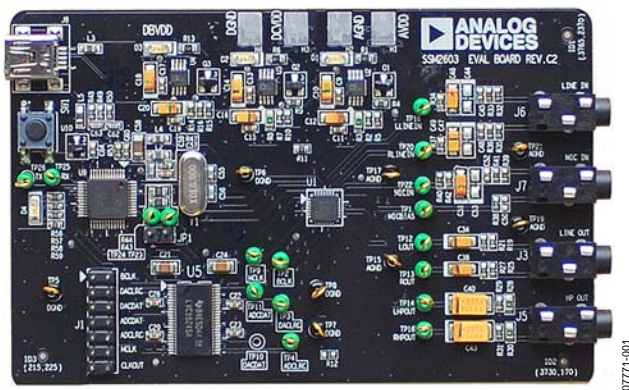

Figure 1. Top View of the SSM2603 Evaluation Board

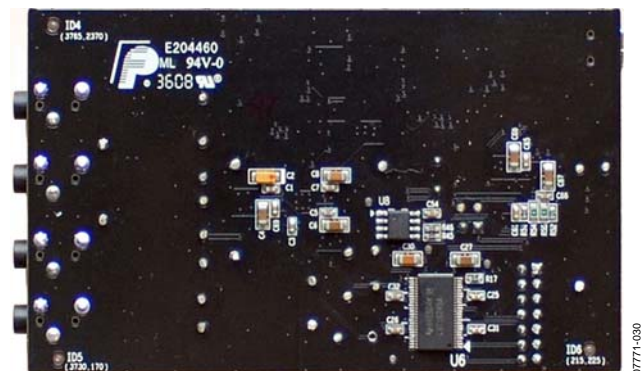

Figure 2. Bottom View of the SSM2603 Evaluation Board

### Rev. 0

Evaluation boards are only intended for device evaluation and not for production purposes. Evaluation boards are supplied "as is" and without warranties of any kind, express, implied, or statutory including, but not limited to, any implied warranty of merchantability or fitness for a particular purpose. No license is granted by implication or otherwise under any patents or other intellectual property by application or use of evaluation boards. Information furnished by Analog Devices is believed to be accurate and reliable. However, no responsibility is assumed by Analog Devices for its use, nor for any infringements of patents or other rights of third parties that may result from its use. Analog Devices reserves the right to change devices or specifications at any time without notice. Trademarks and registered trademarks are the property of their respective owners. Evaluation boards are not authorized to be used in life support devices or systems.

## TABLE OF CONTENTS

Features .....	1	Evaluation Board Quick Setup .....	5
General Description .....	1	GUI Functional Blocks .....	6
Evaluation Board Description.....	1	Evaluation Board Schematics and Artwork.....	8
Revision History .....	2	Ordering Information.....	12
Evaluation Board Hardware.....	3	Bill of Materials.....	12
Hardware Description.....	3	Ordering Guide .....	13
Evaluation Board Software.....	5	ESD Caution.....	13

## REVISION HISTORY

4/09—Revision 0: Initial Version

# EVALUATION BOARD HARDWARE

## HARDWARE DESCRIPTION

The SSM2603 evaluation board can be divided into several segments: the microcontroller unit (MCU) with USB interface, power supplies, analog input/output circuitry, the SSM2603 device, and the digital audio interface and bidirectional digital buffer.

### MCU with USB Interface

The on-board microcontroller (MCU) with USB interface is located on the top left portion of the evaluation board.

- The MCU has two functions: transmitting the SSM2603 registers control word between the host PC and the SSM2603 I<sup>2</sup>C port and transmitting digital audio data between the host PC and the SSM2603 digital audio interface.
- Use SW1 to reset the MCU.
- When the MCU is working correctly, LED D4 is blinking.
- J8 is a mini Type B USB connector.

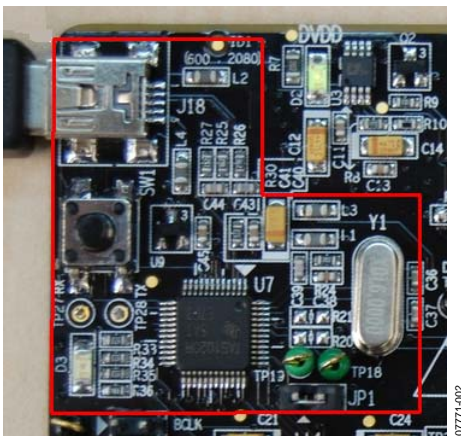

Figure 3. USB Interface Microcontroller

### Power Supplies

The power supplies are located on the top center portion of the board. The entire board is powered through the USB connector. There are three on-board low dropouts (LDOs) deriving 3.3 V from the USB 5 V supply. LED D1, LED D2, and LED D3 indicate power supply status.

- The output from LDO U4 provides the voltage for the digital supply, DBVDD, and the MCU. The LDO output is fixed at 3.3 V.
- The output from LDO U3 provides the voltage for the digital supply, DCVDD. By default, the LDO output is set to 3.3 V. If a voltage other than 3.3 V is needed for DCVDD, the user must remove Resistor R8 and apply the desired external voltage to the power supply pads, DCVDD and DGND, on the top center of the board.

- The output from LDO U2 provides the voltage for the analog supply, AVDD, and the headphone supply, HPVDD. By default, the LDO output is set at 3.3 V. If a voltage other than 3.3 V is needed for AVDD and HPVDD, the user must remove Resistor R3 and apply the desired external voltage to the power supply pads, AVDD and AGND, on the top center portion of the board.

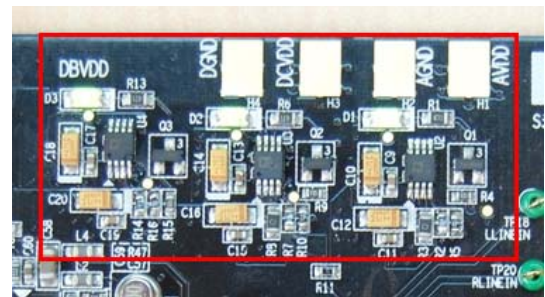

Figure 4. Power Supply Circuitry

### Analog Input/Output Circuitry

The right portion of the SSM2603 board includes analog input and output circuitry for SSM2603. From top to bottom, these are:

- Stereo line input jack
- Mono microphone input jack
- Stereo line output jack
- Stereo headphone output jack

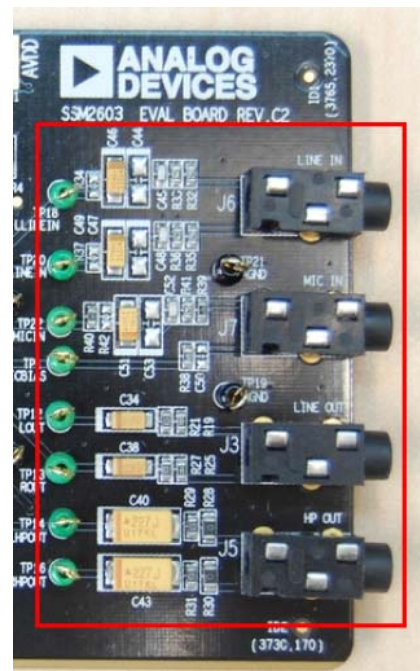

Figure 5. Analog Input/Output Circuitry

# EVAL-SSM2603

## SSM2603 Device

The SSM2603 device is located in the center of the SSM2603 evaluation board.

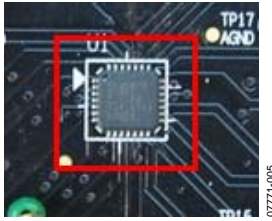

Figure 6. SSM2603 Device

## Digital Audio Interface and Bidirectional Digital Buffer

On the bottom left of the evaluation board are the general-purpose digital audio interface, J1, and the bidirectional digital buffer for digital audio signals.

J1 is for connecting the SSM2603 digital audio interface signals to/from the external DSP or MCU. One column of J1 is DGND and the other column is marked with the name of the digital audio signal (BCLK, DACLRC, DACDAT, ADCDAT, ADCLRC, MCLK, and CLKOUT). These signals are routed to the corresponding SSM2603 digital audio interface signals through the digital buffer.

The buffer is bidirectional. Its direction is controlled in the software.

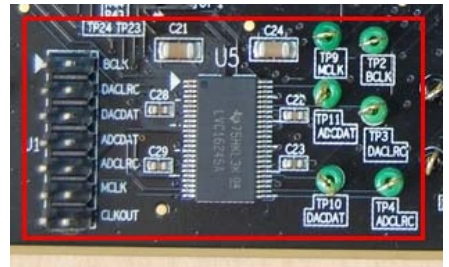

Figure 7. General-Purpose Digital Audio Interface and Buffer

# EVALUATION BOARD SOFTWARE

## EVALUATION BOARD QUICK SETUP

Follow these five steps to quickly set up the evaluation board:

1. Make sure Jumper JP1 is applied.
2. Connect the board to the host PC with a mini Type B USB cable. The Windows system reports that new hardware has been found if it is the first time the board is connected. The PC installs drivers for the new hardware automatically. When installation is complete, **SSM2602/03/04 Eval Board** appears on the status bar of the **Speaker** control panel.

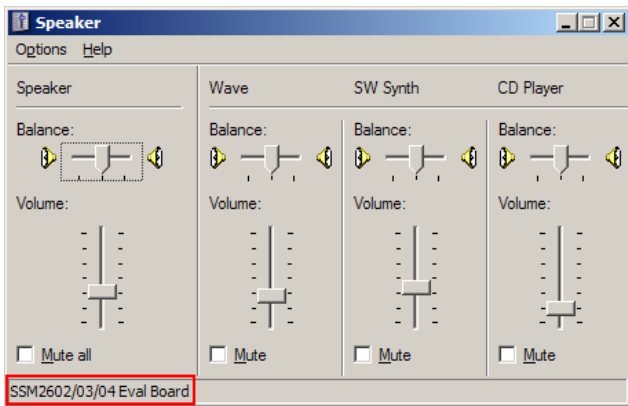

Figure 8. Speaker Control Panel Setting

3. Install the SSM2603 evaluation board control software from **SSM2603 Eval Board.msi**.
4. From the **Start** menu, select **Programs**, then **ADI**, then **SSM2603 Eval Board**, and then **SSM2603.exe** to run the control software. If the USB cable is not connected or Jumper JP1 is not applied before running the software, an error message box appears. Close the software, check the hardware connectivity, and rerun the software until the message box no longer appears.

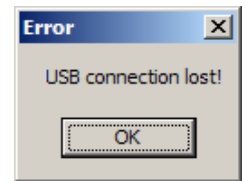

Figure 9. Error Message When USB Connection Is Not Established

5. When installation is complete, the software GUI appears. Click the **DAC** button to play music files in media player. You should be able to hear the music from the headphone or from the active speaker connected to the headphone output jack of the evaluation board. Note that only music files with a 48 kHz or 44.1 kHz sample rate are supported in this mode.

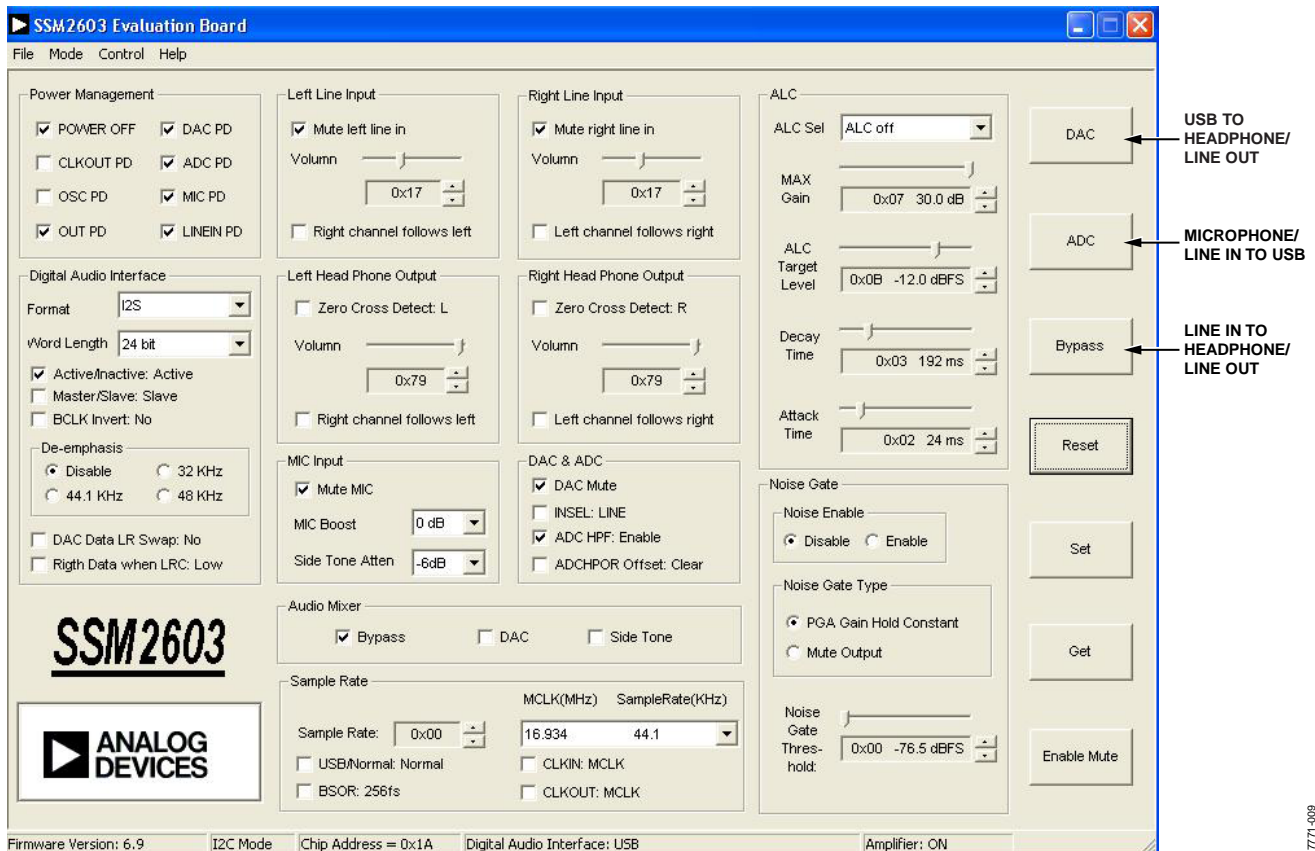

Figure 10. SSM2603 Control Software GUI

# EVAL-SSM2603

## GUI FUNCTIONAL BLOCKS

The software GUI is logically split into menu items, command buttons, and the register control panel. The menu is for setting up the software and hardware working mode. The command buttons are for register access. The register control panel is for viewing and modifying each register.

The SSM2603 supports the I<sup>2</sup>C standard for the register control interface. This is selected under the **Mode** menu. For I<sup>2</sup>C mode, you can select between two device addresses in the **I2C mode** submenu.

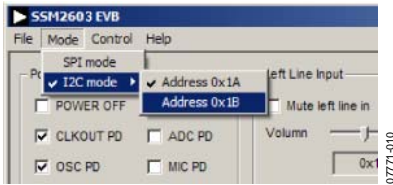

Figure 11. Control Interface Selection

There are two available digital audio interfaces for the SSM2603 on-board. One is the USB MCU. This is used to play back music on the host PC and transmit to the SSM2603 DAC, or to record music with the SSM2603 ADC and transmit to the host PC through a USB connection. The other digital audio interface is the general-purpose connector, J1. This is used to connect to your DSP or MCU. Only one interface can communicate with the SSM2603 at one time, and this is selected under the **Control** menu (see Figure 12).

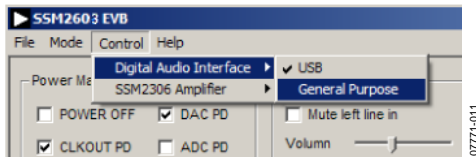

Figure 12. Digital Audio Interface Selection

The **Import** and **Export** utilities are for reading/writing the SSM2603 registers in batch mode. The file import utility reads the register setting from a .txt file and then writes to the SSM2603 internal registers. The file export utility reads the SSM2603 internal registers back and then writes to a .txt file.

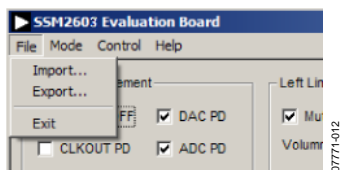

Figure 13. File Import/Export Utility

The .txt file used for SSM2603 register configuration contains multiple lines and each line is for one register. The first word of a line is a 7-bit register address entry, which is in two-digit hexadecimal format. The second word of a line is a 9-bit register value entry, which is in three-digit hexadecimal format. When using the import utility, use the export utility first to generate the software .txt file as a template and then add, remove, or modify the register entries in the template file.

Addr	Value
0x00	0x097
0x01	0x097
0x02	0x079
0x03	0x079
0x04	0x00A
0x05	0x008
0x06	0x09F
0x07	0x00A
0x08	0x000
0x09	0x000
0x10	0x07B
0x11	0x032
0x12	0x00

Figure 14. Register Configuration File Format

After setting the registers in the SSM2603 GUI window, the control software (see Figure 10), and clicking the **Set** button, the settings are configured to the corresponding SSM2603 registers. If the **Set** button is not clicked, the SSM2603 registers are not configured.

The I<sup>2</sup>C is a read and write protocol, so in I<sup>2</sup>C mode, when the **Get** button is clicked, the SSM2603 registers are read back and reflected in the SSM2603 GUI window.

The **Reset** button corresponds to SSM2603 Register R15. When it is clicked, all SSM2603 registers are set to the power-on reset value.

There are three short-cut buttons: **DAC**, **ADC**, and **Bypass**. These are used to quickly set the panel for the DAC path, the ADC path, and the analog line-in to analog line-out loopback path, respectively.

The SSM2603 GUI window is logically split into several different functional blocks. Each functional block represents the underlying internal register of the SSM2603 that corresponds to the block.

### Power Management Control

This section controls SSM2603 Register R6. If an option is checked, the power for that corresponding module is turned off; otherwise, the power is turned on for that part. For example, selecting **POWER OFF** shuts down the chip.

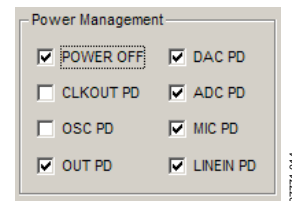

Figure 15. Power Management Control Section

### Line Input Control

This section controls SSM2603 Register R0 and Register R1 for the left and right line input channel, respectively. Note that the **Right channel follows left** option and the **Left channel follows right** option are mutually exclusive.

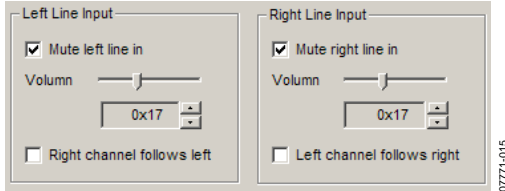

Figure 16. Line Input Control Section

### Headphone Output Control

This section controls SSM2603 Register R2 and Register R3 for the left and right headphone output channel, respectively. Note that the **Right channel follows left** option and **Left channel follows right** option are mutually exclusive.

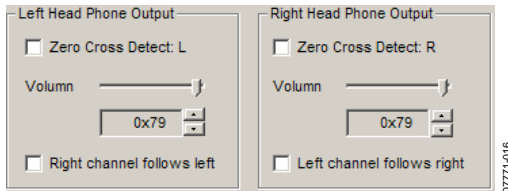

Figure 17. Headphone Output Control Section

### Analog and Digital Audio Path Control

This section controls SSM2603 Register R4 and Register R5 for the analog and digital audio path, respectively. **MIC Input** corresponds to D[8:6] and D[1:0] of R4. **Audio Mixer** corresponds to D[5:3] of R4. **DAC & ADC** corresponds to D[4:3] and D0 of R5 and D2 of R4.

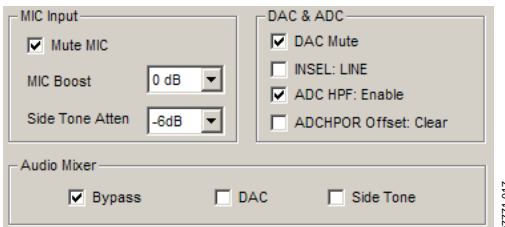

Figure 18. Analog and Digital Audio Path Control Section

### Digital Audio Interface Control

This section controls SSM2603 Register R7 and D[2:1] of Register R5. Specifically, the **Active/Inactive** option corresponds to R9.

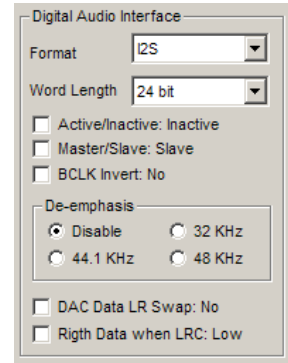

Figure 19. Digital Audio Interface Control Section

### Sample Rate Control

This section controls SSM2603 Register R8.

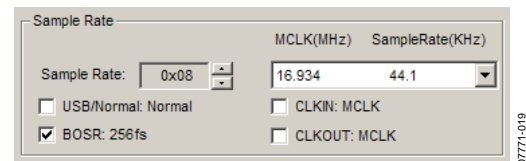

Figure 20. Sample Rate Control Section

### ALC Control

This section controls SSM2603 Register R16 and Register R17.

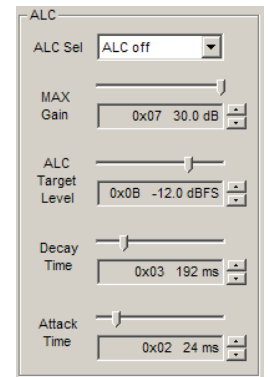

Figure 21. ALC Control Section

### Noise Gate Control

This section controls SSM2603 Register R18.

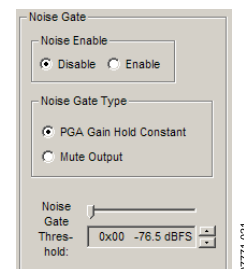

Figure 22. Noise Gate Control Section

# EVAL-SSM2603

## EVALUATION BOARD SCHEMATICS AND ARTWORK

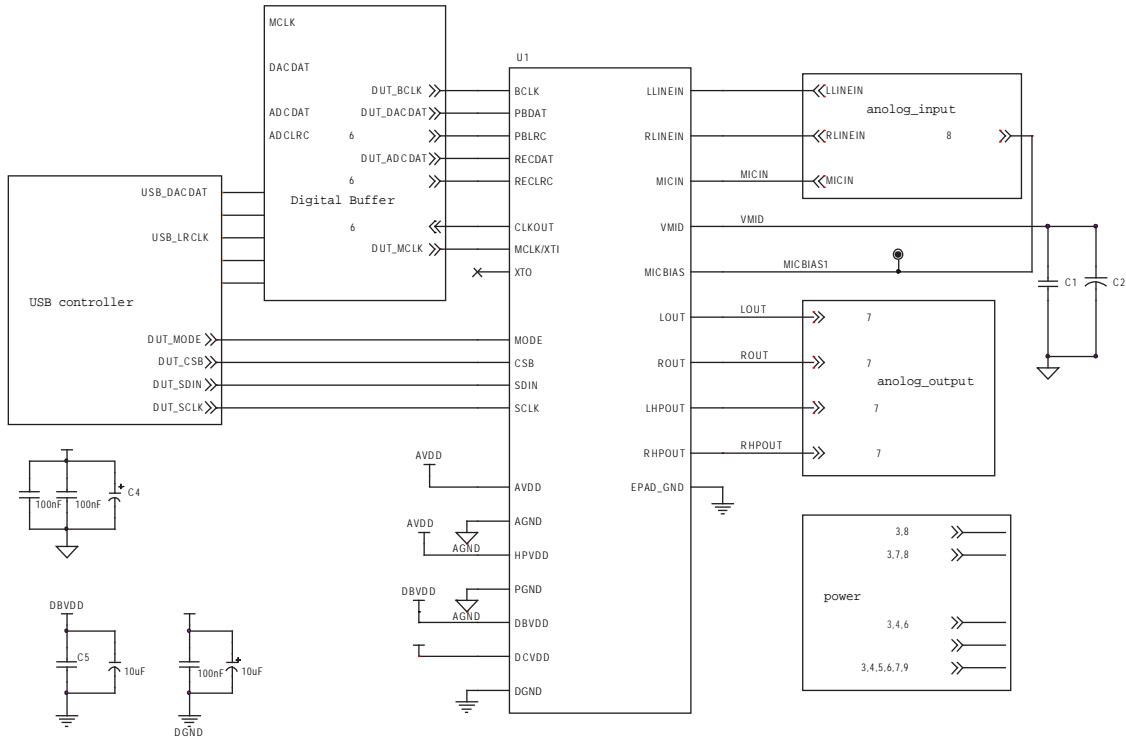

Figure 23. Schematic of SSM2603 Evaluation Board, SSM2603 Chip

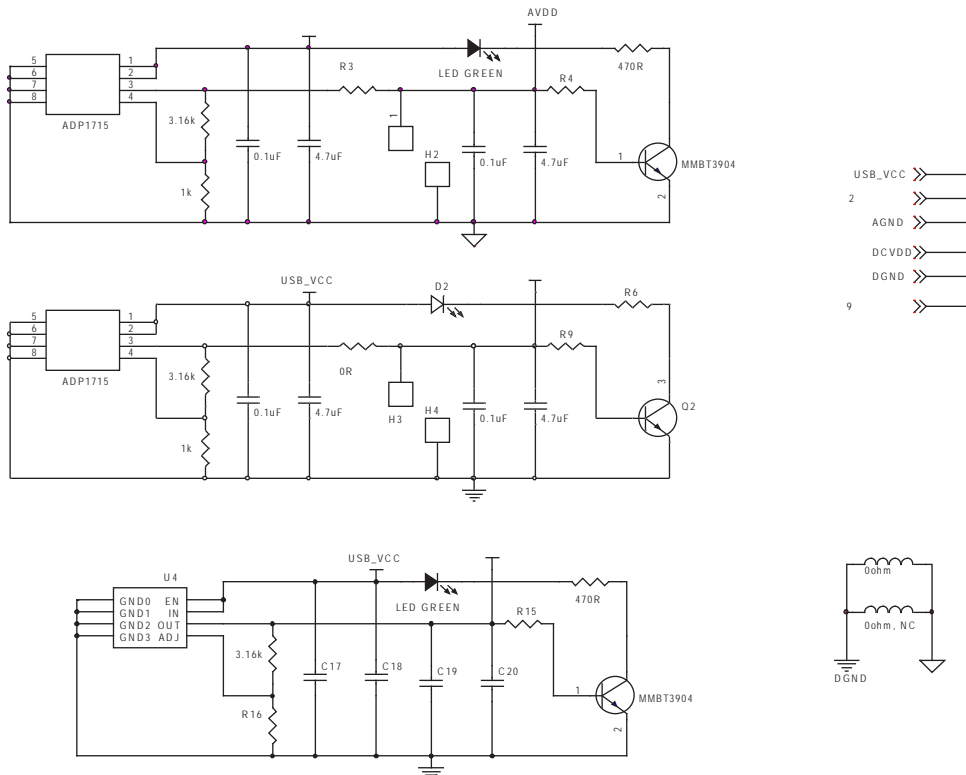
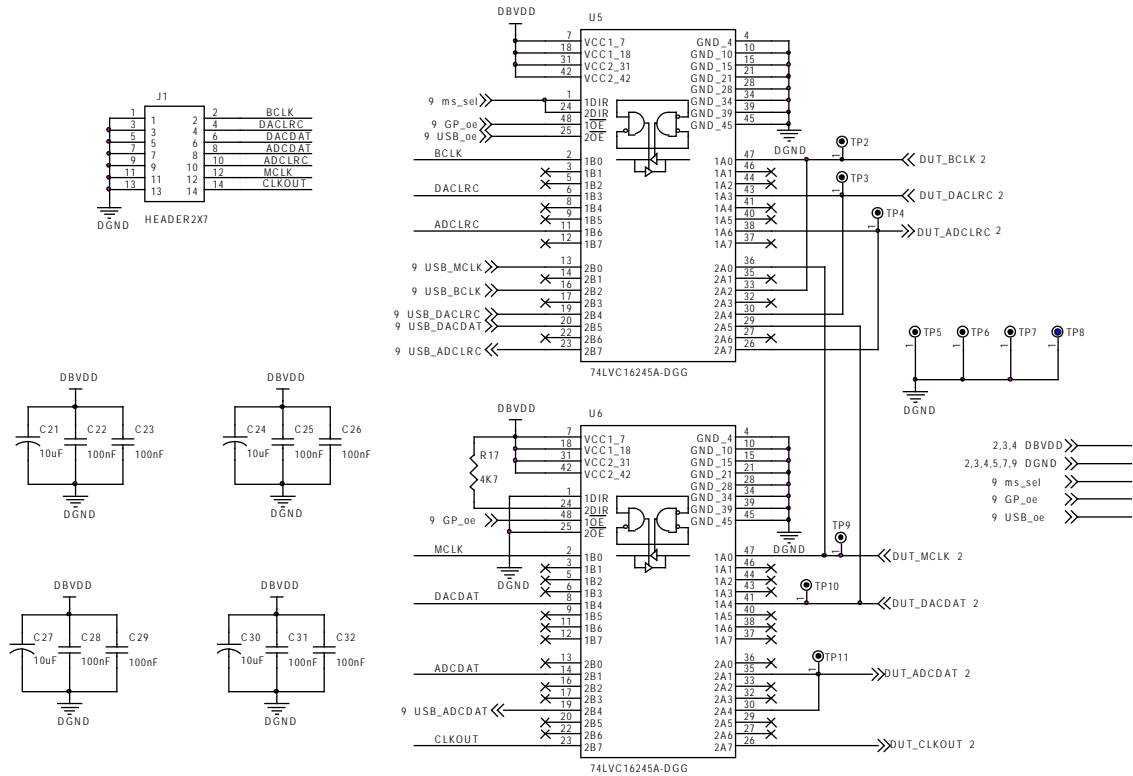
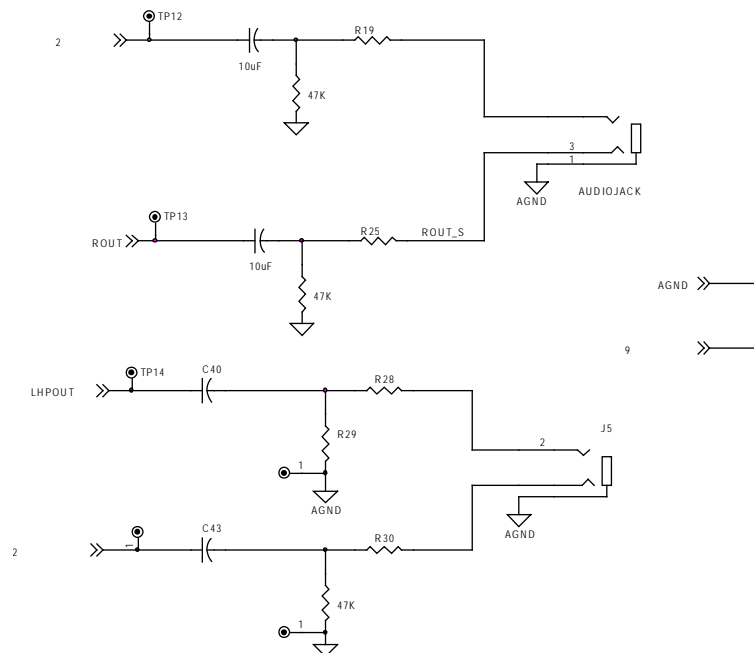

Figure 24. Schematic of SSM2603 Evaluation Board, Power Supply





07687-024



0771-025

# EVAL-SSM2603

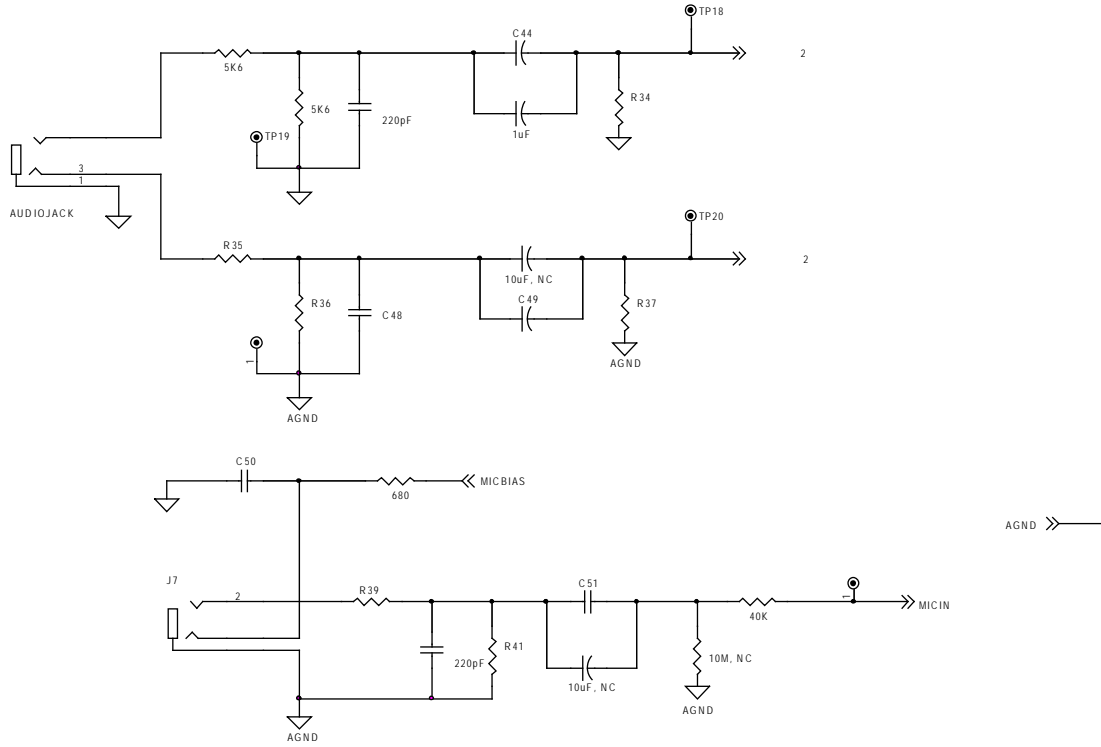

Figure 27. Schematic of SSM2603 Evaluation Board, Analog Input

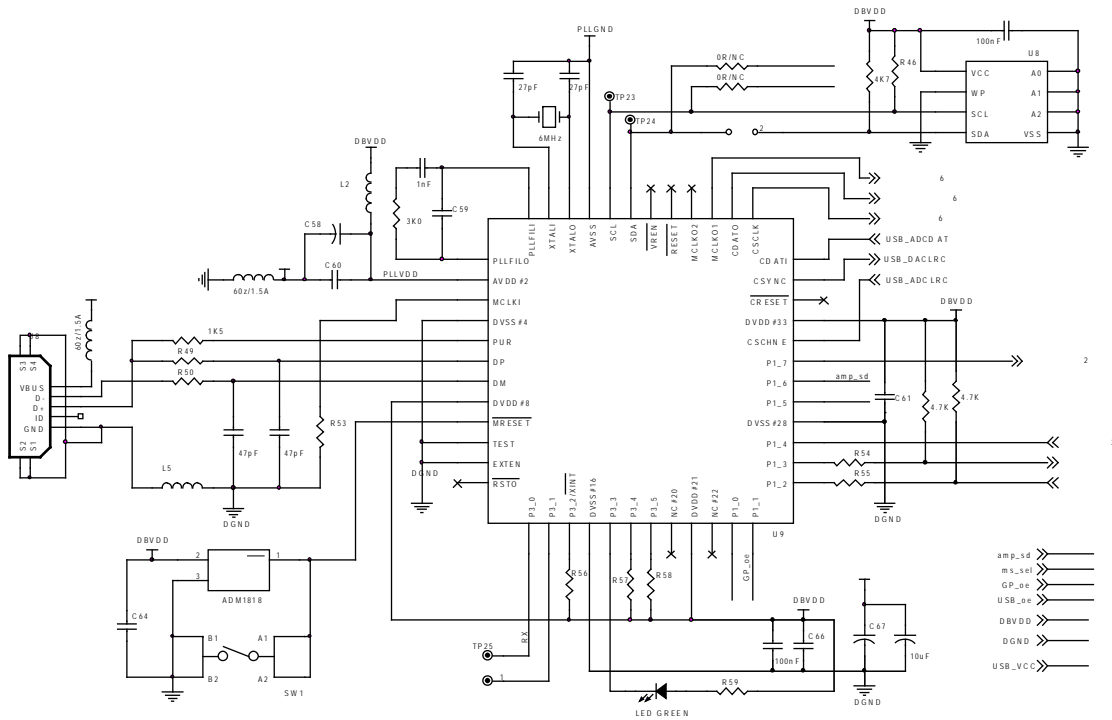

Figure 28. Schematic of SSM2603 Evaluation Board, USB MCU

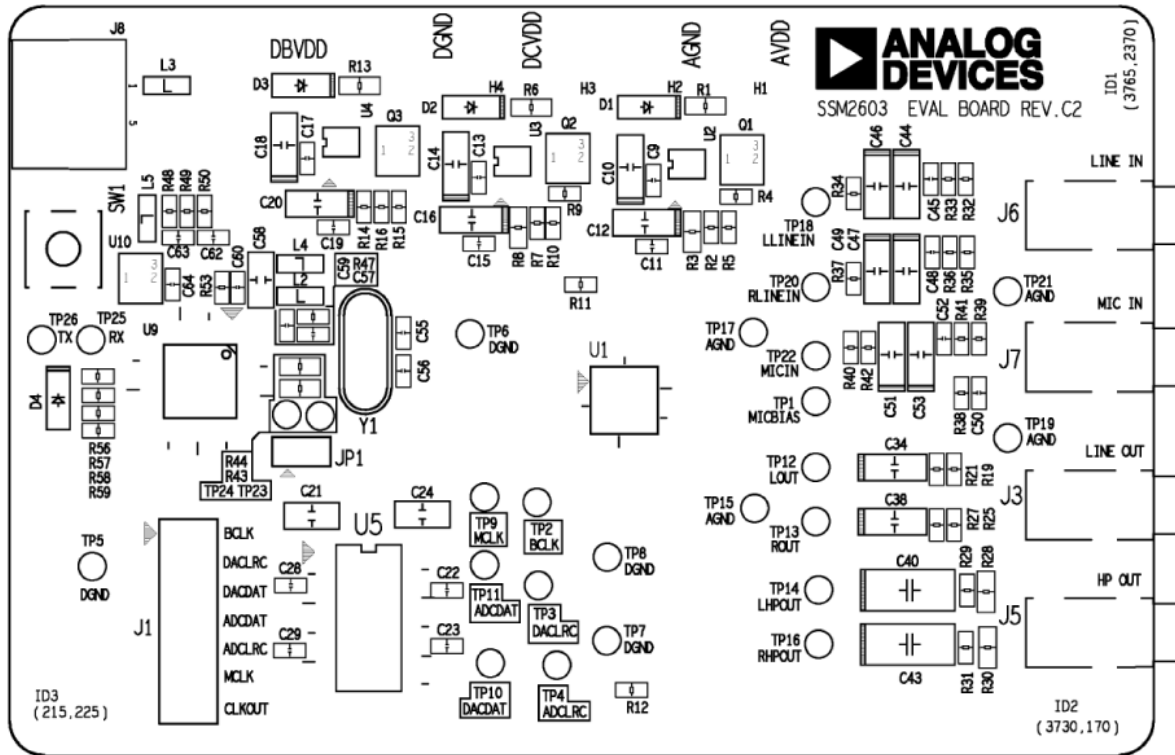

Figure 29. Layout of SSM2603 Evaluation Board, Top Layer

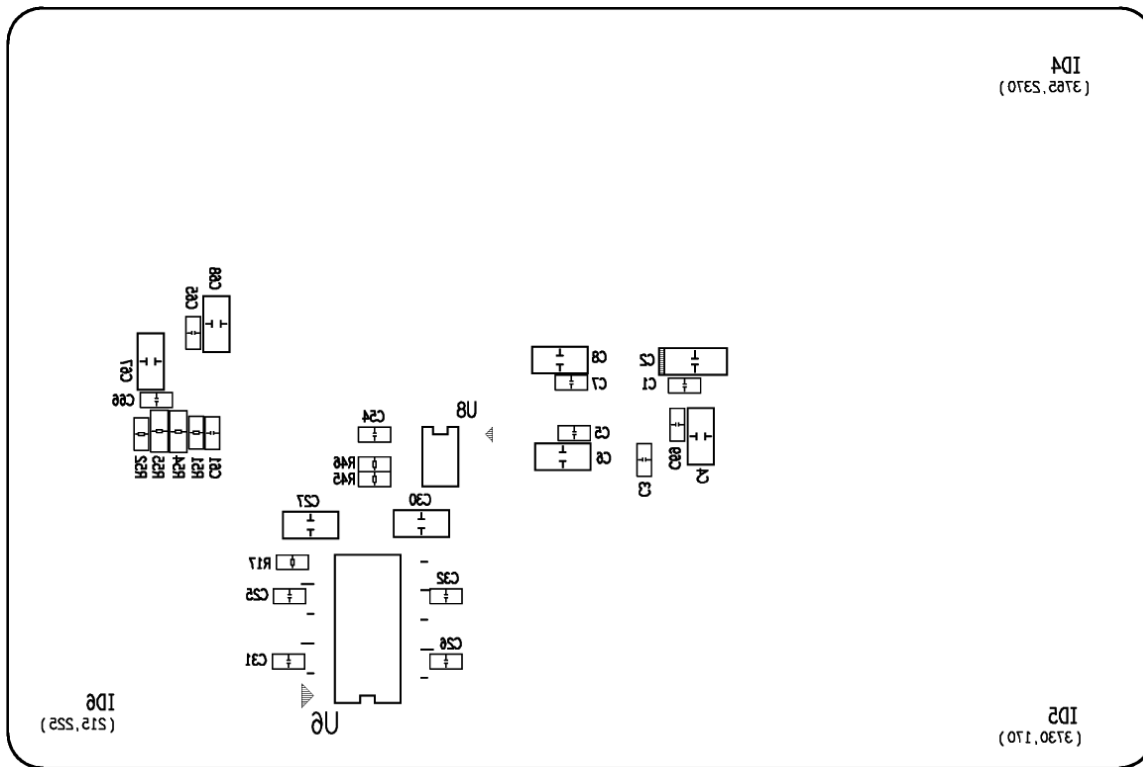

Figure 30. Layout of SSM2603 Evaluation Board, Bottom Layer

# EVAL-SSM2603

## ORDERING INFORMATION

### BILL OF MATERIALS

Table 1.

Qty	Reference Designator	Description	Manufacturer	Part Number
3	C46, C49, C51	1 $\mu$ F capacitor, 3216	TDK	C3216CH1H105J
13	C2, C4, C6, C8, C21, C24, C27, C30, C34, C38, C58, C67, C68	10 $\mu$ F capacitor, 1206	TDK	C1206CH1H106J
6	C10, C12, C14, C16, C18, C20	4.7 $\mu$ F capacitor, 3216	TDK	C3216CH1H475J
25	C1, C3, C5, C7, C9, C11, C13, C15, C17, C19, C22, C23, C25, C26, C28, C29, C31, C32, C54, C60, C61, C64, C65, C66, C69	0.1 $\mu$ F capacitor, 0603	TDK	C0603CH1E104J
3	C44, C47, C53	10 $\mu$ F capacitor, not populated, 3216	TDK	C3216CH1H106J
2	C40, C43	220 $\mu$ F capacitor, 6032	TDK	C6032CH1E227J
2	C55, C56	27 pF capacitor, 0603	TDK	C0603CH1E270J
1	C57	1 nF capacitor, 0603	TDK	C0603CH1E102J
1	C59	100 pF capacitor, 0603	TDK	C0603CH1E101J
2	C62, C63	47 pF capacitor, 0603	TDK	C0603CH1E470J
3	C45, C48, C52	220 pF capacitor, 0603	TDK	C0805CH1E221J
4	D1, D2, D3, D4	LED, 1206	Digi-Key	597-3311-407
1	JP1	HEADER1X2, header, 1 $\times$ 2	Digi-Key	A26508-02-ND
1	J1	HEADER2X7, header, 2 $\times$ 7	Digi-Key	A26508-07-ND
4	J3, J5, J6, J7	AUDIO JACK, STX-3500-3	KYCON	STX-3500-3
1	J8	1734035-1, Mini USB	AMP/Tyco Electronics	1734035-1
4	L2, L3, L4, L5	60z/1.5A, 0805	Murata	BLM21PG600SN1
3	Q1, Q2, Q3	MMBT3904, SOT23	Fairchild	MMBT3904
3	R1, R6, R13	470 $\Omega$ resistor, 0805	Royalohm	0805S4J0474T3E
3	R4, R9, R15	10 k $\Omega$ resistor, 0603	Royalohm	0603S4J0103T3E
3	R2, R7, R14	3.16 k $\Omega$ resistor, 0603	Royalohm	0603S4J3161T3E
3	R5, R10, R16	1 k $\Omega$ resistor, 0603	Royalohm	0603S4J0102T3E
5	R17, R45, R46, R51, R52	4.7 k $\Omega$ resistor, 0603	Royalohm	0603S4J0472T3E
5	R32, R33, R35, R36, R41	5.6 k $\Omega$ resistor, 0603	Royalohm	0603S4J0562T3E
2	R19, R25	100 $\Omega$ resistor, 0603	Royalohm	0603S4J0101T3E
8	R21, R27, R29, R31, R53, R56, R57, R58	47 k $\Omega$ resistor, 0603	Royalohm	0603S4J0472T3E
1	R47	3.0 k $\Omega$ resistor, 0603	Royalohm	0603S4J0303T3E
2	R49, R50	27 $\Omega$ resistor, 0603	Royalohm	0603S4J0272T3E
1	R48	15 k $\Omega$ resistor, 0603	Royalohm	0603S4J0152T3E
1	R40	40 k $\Omega$ resistor, 0603	Royalohm	0603S4J0403T3E
3	R11, R12, R39	0 $\Omega$ resistor, 0603	Royalohm	0603S4J0000T3E
6	R3, R8, R54, R55, R28, R30	0 $\Omega$ resistor, 0805	Royalohm	0805S4J0000T3E
1	R59	330 $\Omega$ resistor, 0603	Royalohm	0603S4J0331T3E
1	R38	680 $\Omega$ resistor, 0603	Royalohm	0603S4J0681T3E
3	R34, R37, R42	10 M $\Omega$ resistor, 0603	Royalohm	0603S4J0106T3E
1	SW1	Pushbutton	Panasonic	EVQ-PHP03T
15	TP1, TP2, TP3, TP4, TP5, TP6, TP7, TP8, TP9, TP10, TP11, TP15, TP17, TP19, TP21	Black test point, Header1		N/A
11	TP12, TP13, TP14, TP16, TP18, TP20, TP22, TP23, TP24, TP25, TP26	Green test point, Header1		N/A
1	U1	SSM2603-LFCSP28, 28-lead LFCSP	Analog Devices	SSM2603CPZ
3	U2, U3, U4	ADP1715, SOP8-26-195	Analog Devices	ADP1715
2	U5, U6	74LVC16245A-DGG, SOP48-20-320	NXP	74LVC16245ADGG

Qty	Reference Designator	Description	Manufacturer	Part Number
1	U8	24LC64, SOP8-50-235	Microchip	24LC64
1	U9	TAS1020B, QFP48-20-355	TI	TAS1020B
1	U10	ADM1818, SOT-23	Analog Devices	ADM1818
1	Y1	6 MHz, Osc2-190-430x175	ECS	ECS-60-32-4X

**ORDERING GUIDE**

Model	Description
SSM2603-EVALZ <sup>1</sup>	Evaluation Board

<sup>1</sup> Z = RoHS Compliant Part.

**ESD CAUTION**



**ESD (electrostatic discharge) sensitive device.** Charged devices and circuit boards can discharge without detection. Although this product features patented or proprietary protection circuitry, damage may occur on devices subjected to high energy ESD. Therefore, proper ESD precautions should be taken to avoid performance degradation or loss of functionality.

**NOTES**

**NOTES**

**NOTES**