

AS SHOWN TPA 50mm2 6

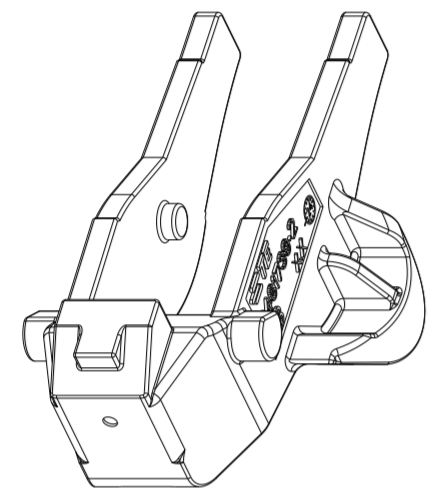

AS SHOWN TPA 70mm2 6

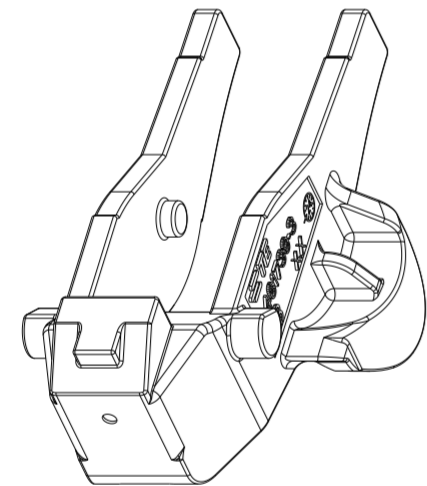

AS SHOWN TPA 95mm2 6

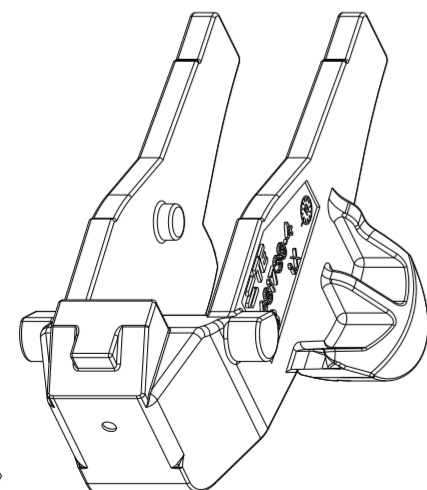

AS SHOWN TPA 35mm2 6

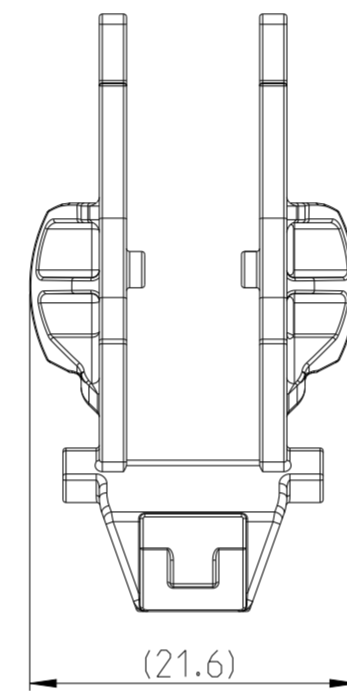
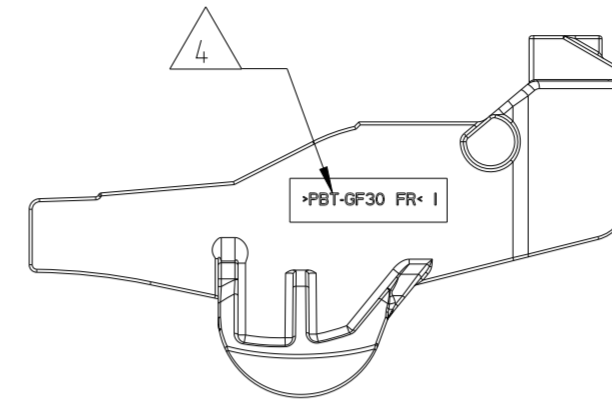
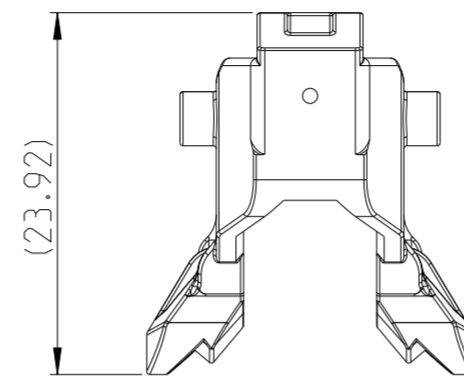
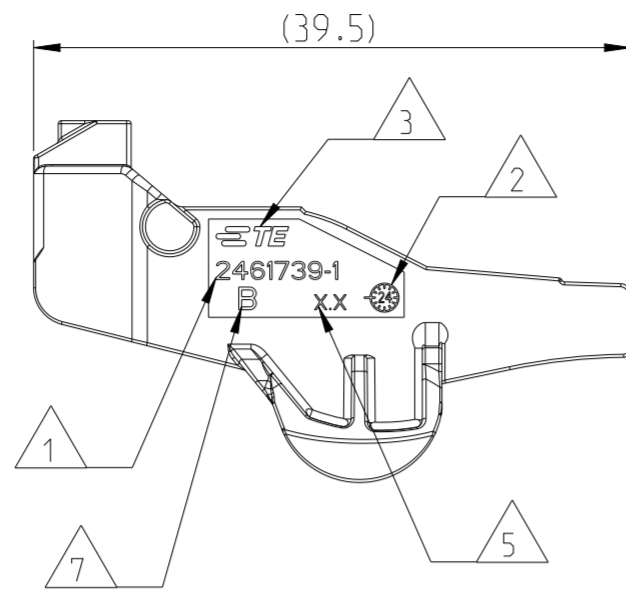

AS SHOWN 2461739-1

DELIVERY CONDITION:
Lieferzustand

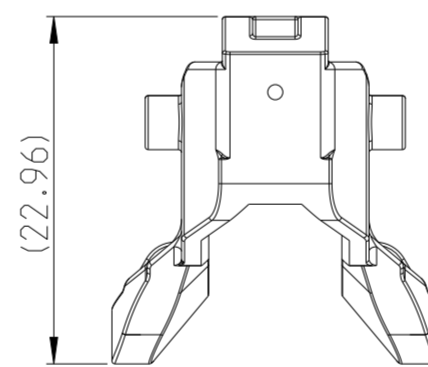
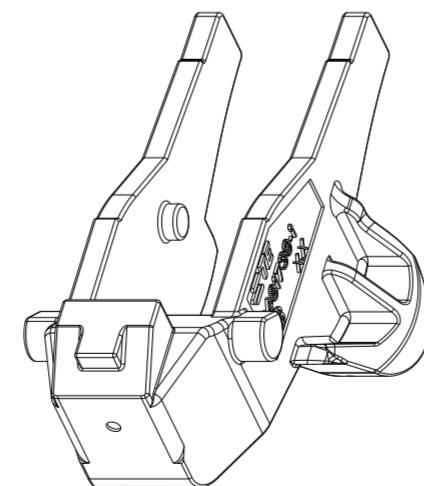

AS SHOWN 2461739-2

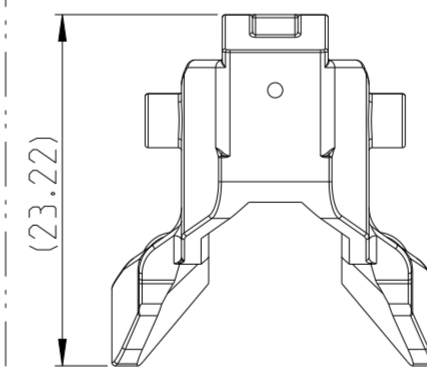

AS SHOWN 2461739-3

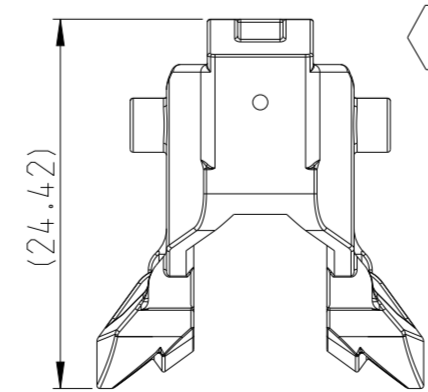

AS SHOWN 2461739-4

REVISIONS					
P	LTR	DESCRIPTION	DATE	DWN	APVD
	B	NEW DRAWING	13AUG2025	MF	PW
B1	B1	ECN-25-343823: NEW VARIANTS	15AUG2025	MF	PW

NOTES
Bemerkungen

- 1 TE CONNECTIVITY (TE) ORDER-NO.
TE CONNECTIVITY (TE) Bestellnr.
- 2 PRODUCTION DATE
Produktionsdatum
- 3 TE-LOGO
TE-Logo
- 4 MATERIAL MARKING
Materialkennzeichnung
- 5 CONTACT CAVITY NUMBERING
Kammernummerierung
- 6 DIFFERENT RUNNER SIZES
Unterschiedliche Läufergrößen
- 7 REVISION STATUS OF THE MOULD
Änderungsstand des Werkzeugs
- 8 SUITABLE TO COUNTERPART PN 2461715, 2461719, 2461722, 2461726
Passend zu Gegenstück PN 246171; 2461719, 2461722, 2461726
- 9 USED WITH PN 2461740-1
Wird genutzt mit PN 2461740-1
- 10 MALFUNCTION CAUSED BY LACQUER IS NOT COVERED BY TE WARRANTY.
Funktionsbeeinträchtigung durch Lackieren liegt nicht im Einfluss und Gewährleistungsumfang von TE
- 11 PACKED IN CORRUGATED SHIPPING BOX
Verpackt im Versandkarton

DIMENSION AND TOLERANCES ACCORDING TO:
Bemaßungen und Toleranzen gemäß:

DIN ISO 20457
DIN EN ISO 8015 (AD) - DIN EN ISO 291
DIN EN ISO 14405-1/-2/-3

ORDER-NO. Bestell-Nr.	MAT.	COLOUR/Farbe SURFACE/Oberfl.	DESCRIPTION Beschreibung	WEIGHT [g]	REV.	ITEM
2461739-4	PBT-GF30 FR	GREEN Grün	TPA REC HSG, PCON21, 35 mm2 Zweite Kosi, Buchsengeh, PCON21 35 mm2	3.21	B	4
2461739-3	PBT-GF30 FR	GREY Grau	TPA REC HSG, PCON21, 95 mm2 Zweite Kosi, Buchsengeh, PCON21 95 mm2	3.21	B	3
2461739-2	PBT-GF30 FR	LIGHT BLUE Lichtblau	TPA REC HSG, PCON21, 70 mm2 Zweite Kosi, Buchsengeh, PCON21 70 mm2	3.21	B	2
2461739-1	PBT-GF30 FR	BLACK Schwarz	TPA REC HSG, PCON21, 50 mm2 Zweite Kosi, Buchsengeh, PCON21 50 mm2	2.9	B	1

THIS DRAWING IS A CONTROLLED DOCUMENT.

DWN M. Floesser	12AUG2025	STE TE Connectivity
CHK P. Wrobel	12AUG2025	
APVD F. Eltrop	13AUG2025	
PRODUCT SPEC 108-94935		
APPLICATION SPEC 114-97587		NAME TPA REC HSG, PCON21 Zweite Kosi, Buchsengeh, PCON21
MATERIAL -	FINISH -	SIZE A2
CUSTOMER DRAWING		CAGE CODE 00779
		DRAWING NO C-2461739
		RESTRICTED TO -
		SCALE 2:1
		SHEET 1 OF 1
		REV B1