

Compact Intelligent Power Module (IPM) Motor Control Development Kit (MDK) 1 kW

This User Guides refer to revision 0.4 of the SECO-1KW-MCTRL-GEVK evaluation board.

Description

This user guide provides practical guidelines for compact Intelligent Power Module (IPM) evaluation board with interleaved power factor Correction (PFC) SECO-1KW-MCTRL-GEVB including its main features and key data. The board is fully compatible with the *Universal Controller Board (UCB)*, based on the Xilinx Zynq-7000 SoC, which embeds FPGA logic and two ARM Cortex-A9 processors. As such, the system is fit for high-end control strategies and enables operation of a variety of motor technologies (AC induction motor, PMSM, BLDC, etc.). The board was developed to support customers during their first steps designing application with IPM and PFC. The design was tested as described in this document but not qualified regarding safety requirements or manufacturing and operation over the whole operating temperature range or lifetime. The board is intended for functional testing under laboratory conditions and by trained specialists only.

Collateral

- [SECO-1KW-MCTRL-GEVB](#)
- [Universal Controller Board \(UCB\)](#)
- [NFAQ1060L36T](#)
- [NCP1632](#)
- [FCPF125N65S3](#)
- [NCP1063](#)
- [NCS2003](#)
- [NCS2250](#)



ON Semiconductor®

www.onsemi.com

Eval Board User's Manual

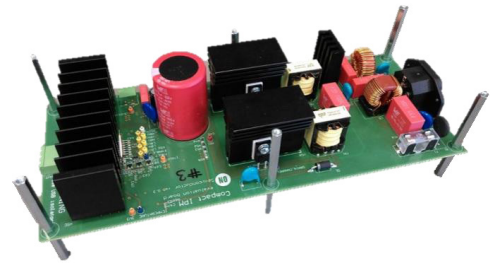

Features

- 850 W complete motor control solution with AC mains supply 230 Vrms $\pm 15\%$, EMI filter, 2-channel interleaved Power Factor Correction (PFC)
- Compatible with Universal Controller Board (UCB) FPGA-controller based on Xilinx Zynq-7000 SoC
- User-friendly GUI with V/f and FOC control use cases for rapid evaluation
- Highly integrated power module NFAQ1060L36T containing an inverter power stage for a high voltage 3-phase inverter in a DIP-S3 package
- PFC stage using NCP1632 controller, FCPF125N65S3 NMOS power transistors and FFSPF1065A diodes
- DC/DC converter producing auxiliary power supply 15VDC – non-isolated buck converter using NCP1063
- 3 phase current measurement using 3 x NCS2003 operational amplifier
- Over current protection using NCS2250 comparator



Attention: The SECO-1kW-MCTRL-GEVB is powered by AC Mains, and exposed to high voltage. Only trained personnel should manipulate and operate on the system. Ensure that all boards are properly connected before powering, and that power is off before disconnecting any boards. It is mandatory to read the Safety Precautions section before manipulating the board. Failure to comply with the described safety precautions may result in personal injury or death, or equipment damage.

Overview

The block diagram of the whole system is represented in Figure 1. The picture of the real board is in the Figure 2 and Figure 3.

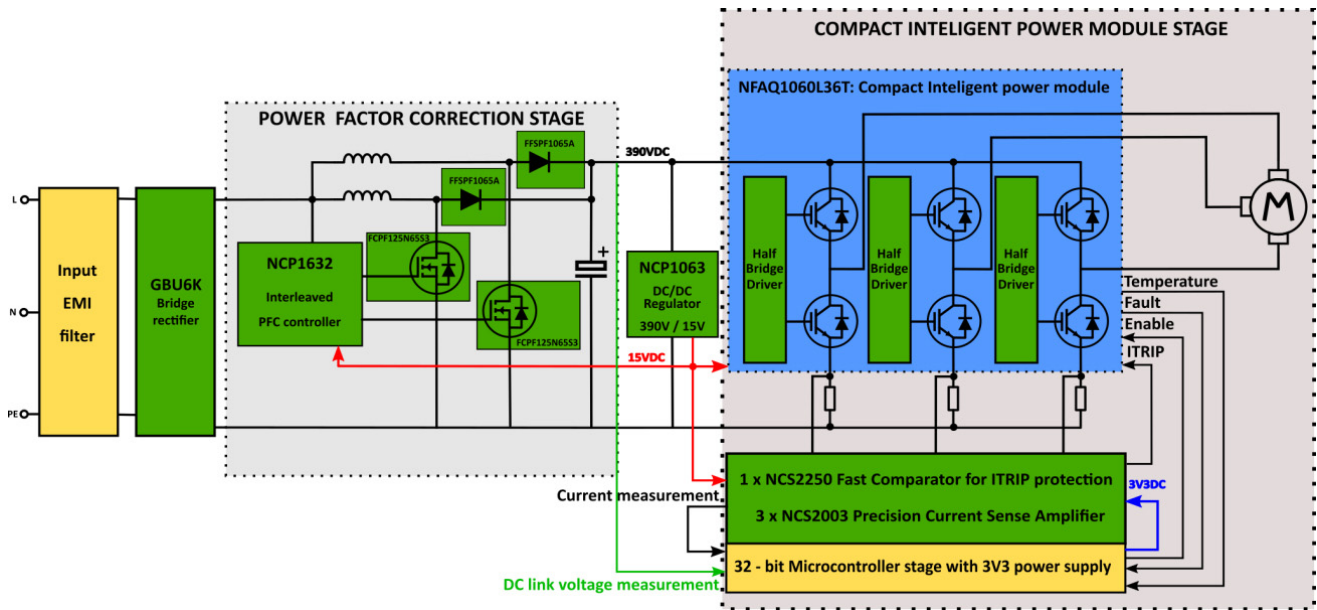

Figure 1. Block Diagram of the Evaluation Board

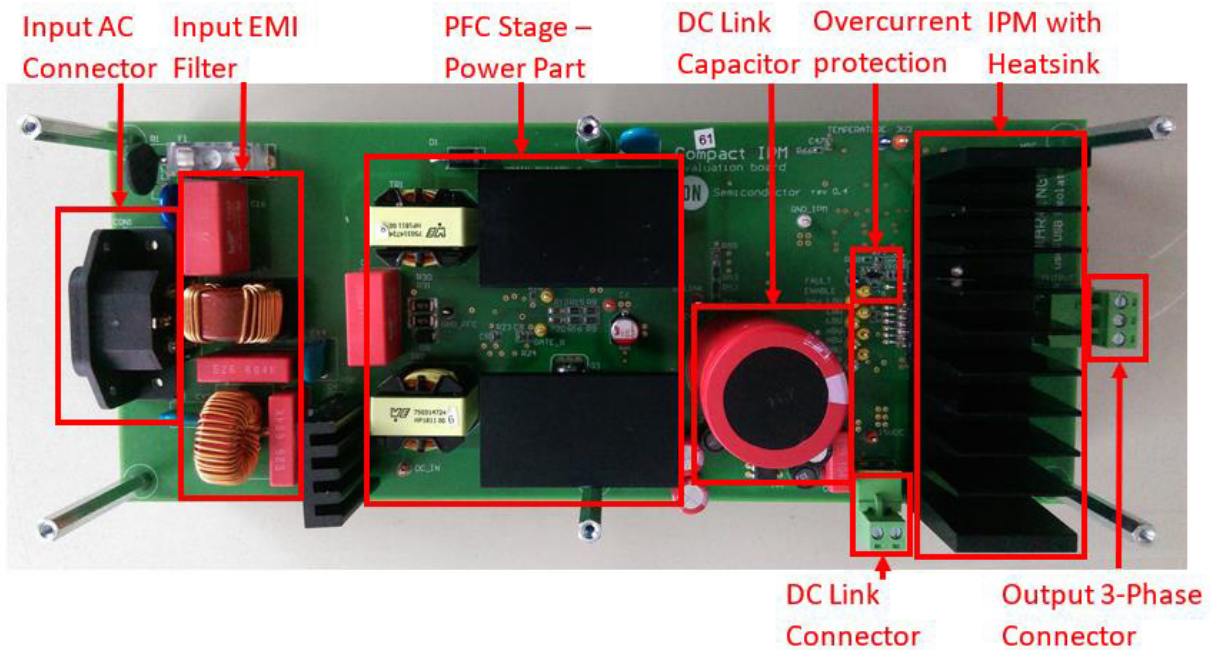

Figure 2. Picture of the Evaluation Board – Top Side

EVBUM2775/D

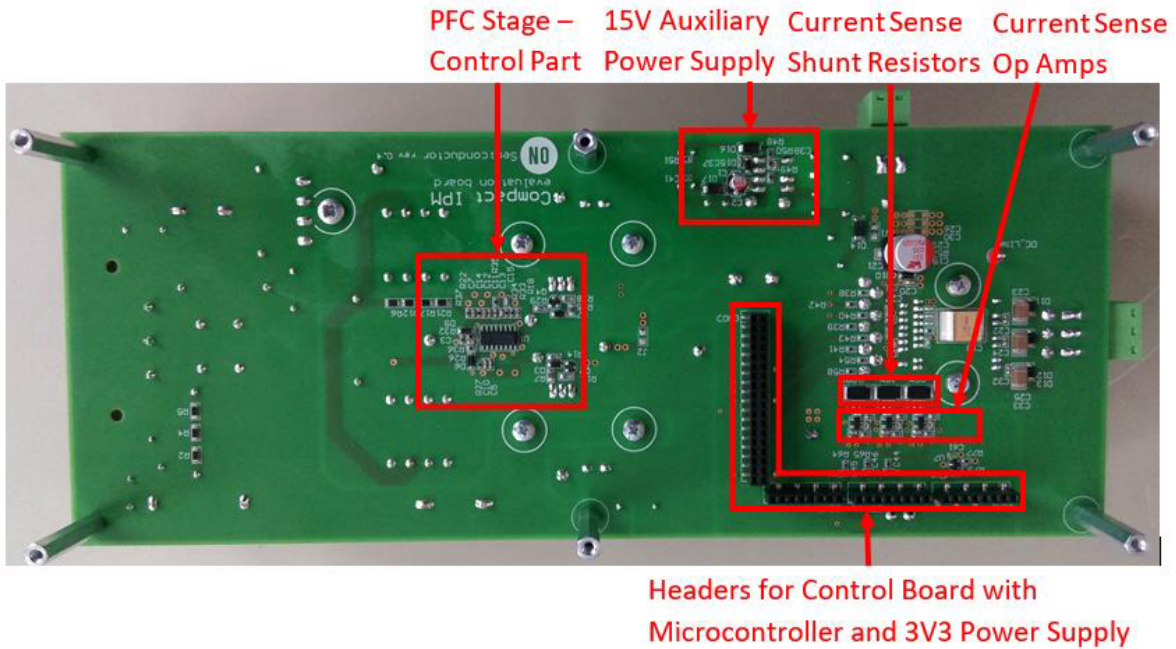
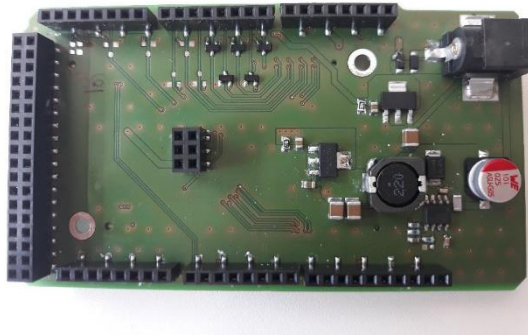
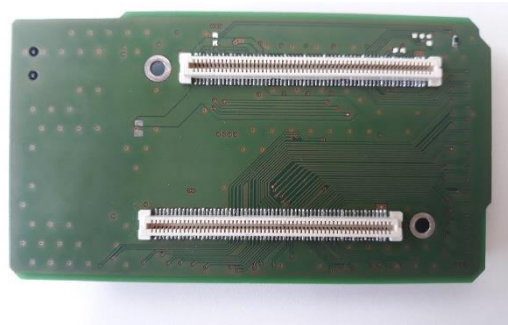

Figure 3. Picture of the Evaluation Board – Bottom Side



(Top Side)



(Bottom Side)

Figure 4. Picture of the UCB Adapter

PREREQUISITES

Hardware

- SECO-1 kW-MCTRL-GEVB (includes power board and adapter for UCB)
- AC power cord one-phase
- Universal Controller Board (UCB) or pin-compatible controller board
- USB isolator (5 kV optical isolation)
- HF ferrite clamp i.e. WE 7427154

Software

- [Downloadable GUI](#)
- [Binary file](#)

EVBUM2775/D

SPECIFICATION

The specification and main features can be seen in the Table 1.









Table 1. EVALUATION BOARD SPECIFICATIONS

Parameters	Values	Conditions/comments
INPUT		
Voltage	230 V _{rms} ± 15%	
OUTPUT		
Power	850 W	Input 230 V _{AC} , f _{PWM} = 16 kHz, T _A = 25°C
Current per IPM leg	±5 A _{rms}	T _C = 100°C
DC BUS Voltage	390 V	Higher voltage value is created by interleaved PFC with NCP1632 working as a booster
CURRENT FEEDBACK		
Current sensing resistors	39 mΩ	
Op Amp power supply	3.3 V	
Set Op Amp gain	5	
Set output offset	1.65 V	Because of negative current measurement
Overcurrent protection	9 A _{peak}	Configured by shunt resistors and comparator threshold (voltage divider)
AUXILIARY POWER SUPPLY		
15 V	4.6 W	Used NCP1063
CONTROL		
Board with Microcontroller and 3V3 power supply		Arduino DUE headers
Type of control		V/f, Field Oriented Control (Sensor-less)
Supported type of motors		ACIM, PMSM, BLDC
APPLICATION		
White goods (washers), Industrial fans, Industrial automation		

SAFETY PRECAUTIONS

It is mandatory to read the following precautions before manipulating the SECO-1KW-MCTRL-GEVB.

Table 2.

SECO-1KW-MCTRL-GEVB	
	The ground potential of the system is biased to a negative DC bus voltage potential. When measuring voltage waveform by oscilloscope, the scope's ground needs to be isolated. Failure to do so may result in personal injury or death
	The ground potential of the system is NOT biased to an earth (PE) potential. When connecting the MCU board via USB to the computer, the appropriate galvanically isolated USB isolator have to be used. The recommended isolation voltage of USB isolator is 5 kV
	SECO-1KW-MCTRL-GEVB system contains DC bus capacitors which take time to discharge after removal of the main supply. Before working on the drive system, wait ten minutes for capacitors to discharge to safe voltage levels. Failure to do so may result in personal injury or death.
	Only personnel familiar with the drive and associated machinery should plan or implement the installation, start-up and subsequent maintenance of the system. Failure to comply may result in personal injury and/or equipment damage.
	The surfaces of the drive may become hot, which may cause injury.
	SECO-1KW-MCTRL-GEVB system contains parts and assemblies sensitive to Electrostatic Discharge (ESD). Electrostatic control precautions are required when installing, testing, servicing or repairing this assembly. Component damage may result if ESD control procedures are not followed. If you are not familiar with electrostatic control procedures, refer to applicable ESD protection handbooks and guidelines.
	A drive, incorrectly applied or installed, can result in component damage or reduction in product lifetime. Wiring or application errors such as under sizing the motor, supplying an incorrect or inadequate AC supply or excessive ambient temperatures may result in system malfunction.
	Remove and lock out power from the drive before you disconnect or reconnect wires or perform service. Wait ten minutes after removing power to discharge the bus capacitors. Do not attempt to service the drive until the bus capacitors have discharged to zero. Failure to do so may result in personal injury or death.
	SECO-1KW-MCTRL-GEVB system is shipped with packing materials that need to be removed prior to installation. Failure to remove all packing materials which are unnecessary for system installation may result in overheating or abnormal operating condition.

SCHEMATICS AND LAYOUT

To meet customer requirements and make the evaluation board a basis for development, all necessary technical data like schematics, layout and components are included in this chapter. Also simple measurements were done to show the functionality of individual stages.

Input EMI Filter

Figure 5 depicts schematic from AC input to rectifier input. This circuitry include a passive EMI filter consisting of elements C16, L5, CY1, CY3, CY4, C51, L4 and C17.

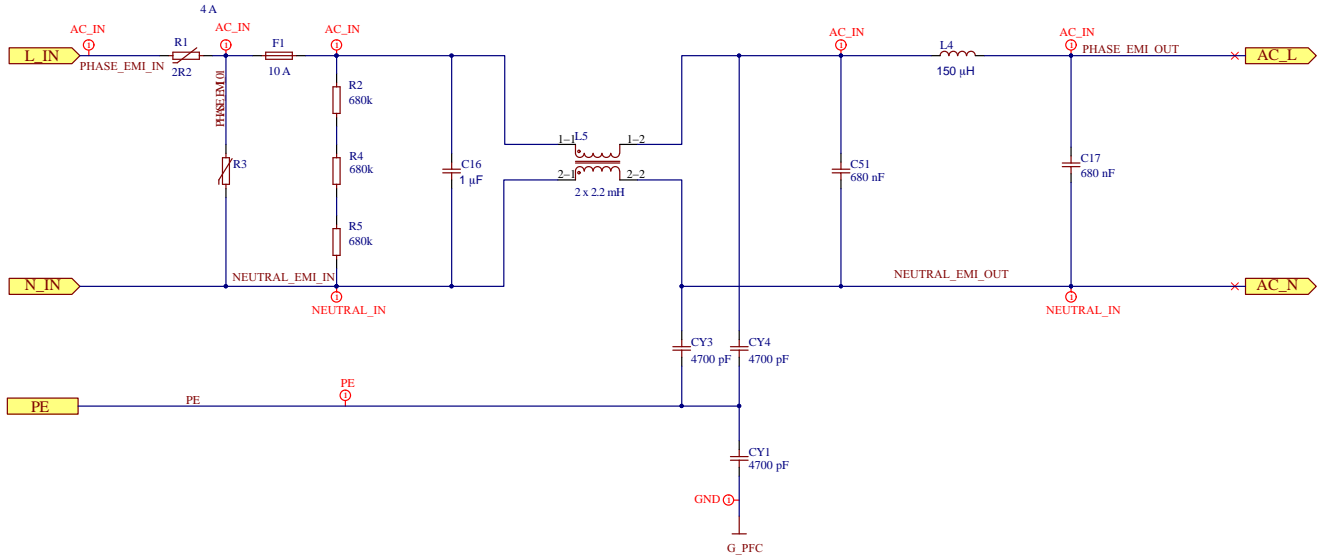

Figure 5. Schematic of EMI filter

Interleaved PFC Stage

In higher power applications to utilize full capacity power of mains and reduce harmonics is PFC-regulators generally required. This high power application use interleaved PFC stages, where may reduce inductor size, input and output capacitors ripple current. In overall, power components are smaller include capacitors. The NCP1632 as voltage mode IC for interleaved PFC applications used in conduction

critical mode. It drives two mosfets 180° phase shifted. The most important at design should be focused significant inductance value of selected PFC coils. It significantly specifies working range.

Figure 6 depicts schematic from rectifier input to DC link output. *Activation of stage (connection to 15 V DC power supply) is via J2 (soldered pads).*

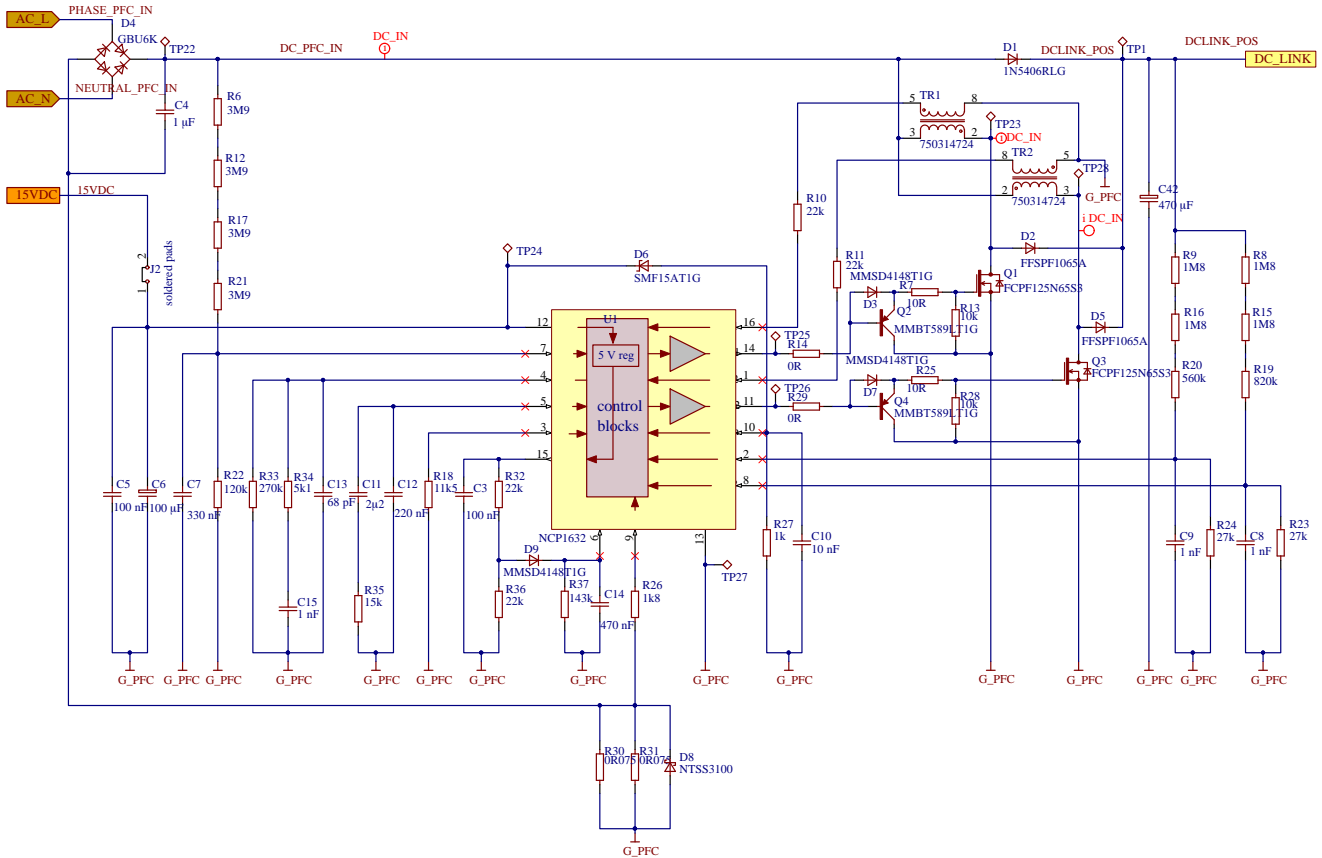

Figure 6. Schematic of interleaved PFC stage

EVBUM2775/D

Basic tests and measurements were done. The results of efficiency, power factor, power losses, load transients and

startup can be seen in the Figures 7–13. The used load was Halogen light bulb.

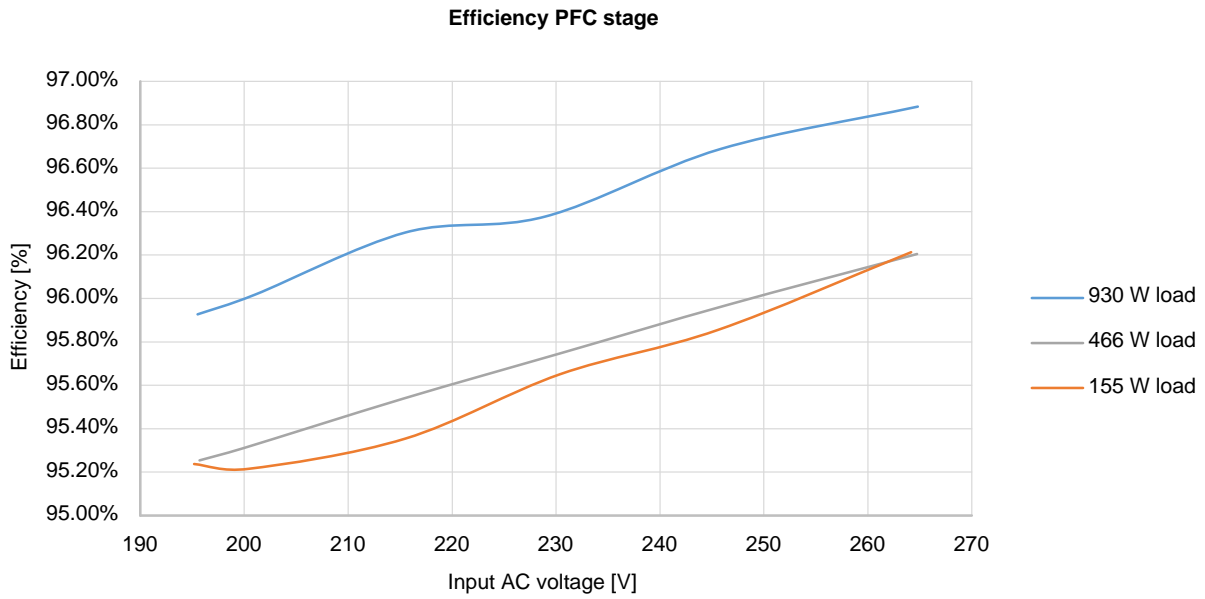

Figure 7. Efficiency of PFC Stage for Various Value of Input AC Voltage and Load

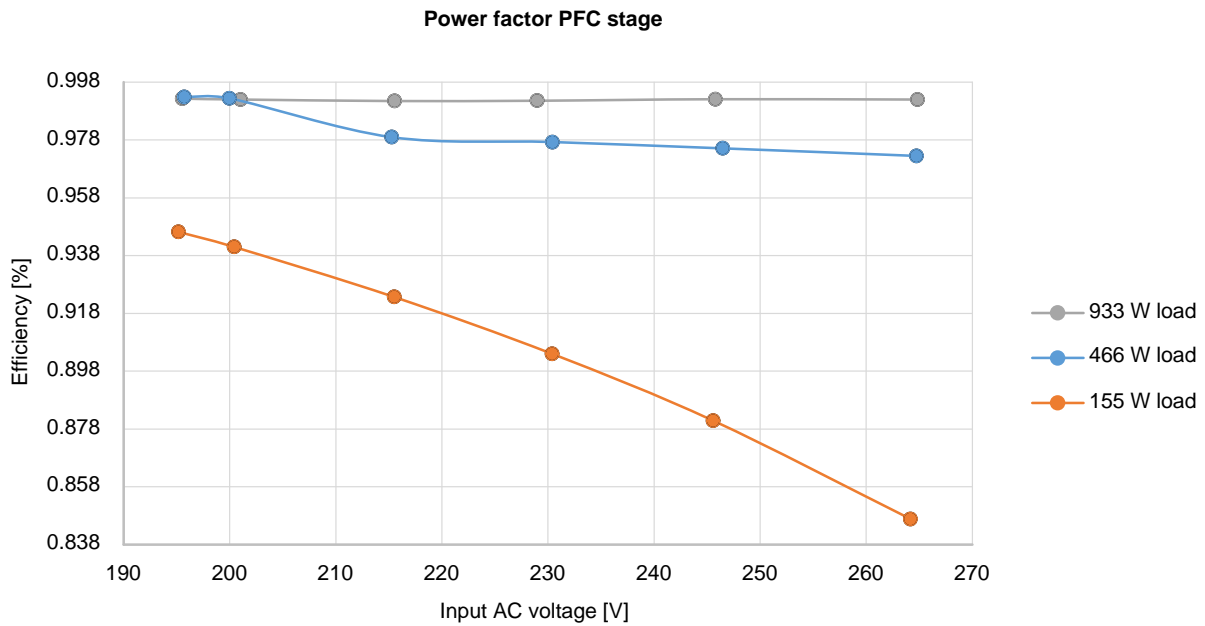

Figure 8. Power Factor of PFC Stage for Various Value of Input AC Voltage and Load

EVBUM2775/D

Power factor PFC stage

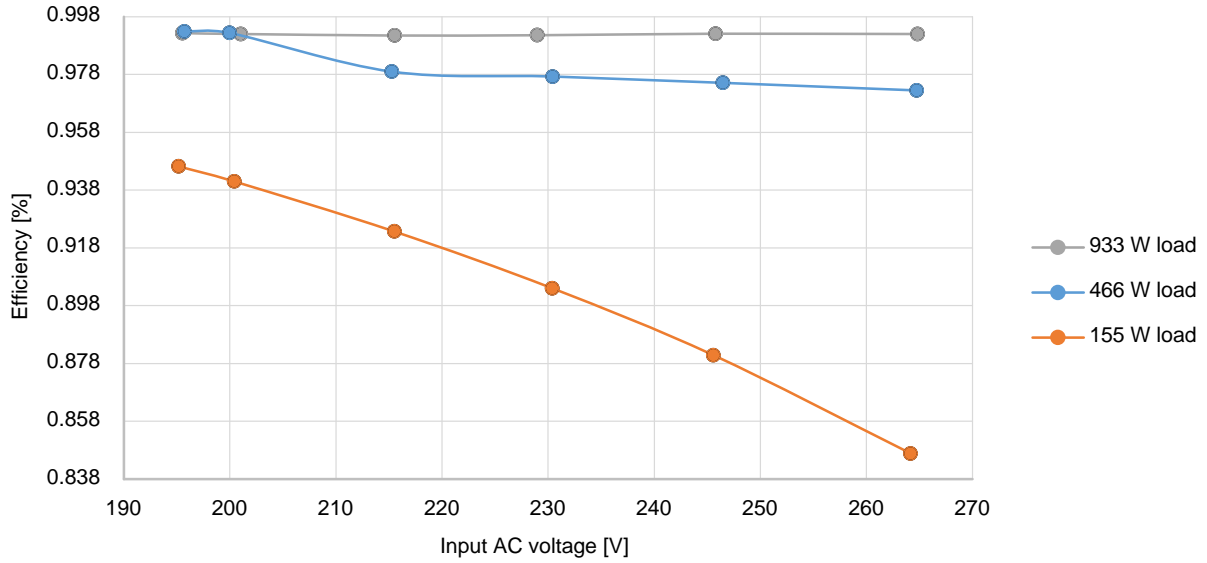

Figure 9. Power Losses of PFC Stage for Various Value of Input AC Voltage and Load

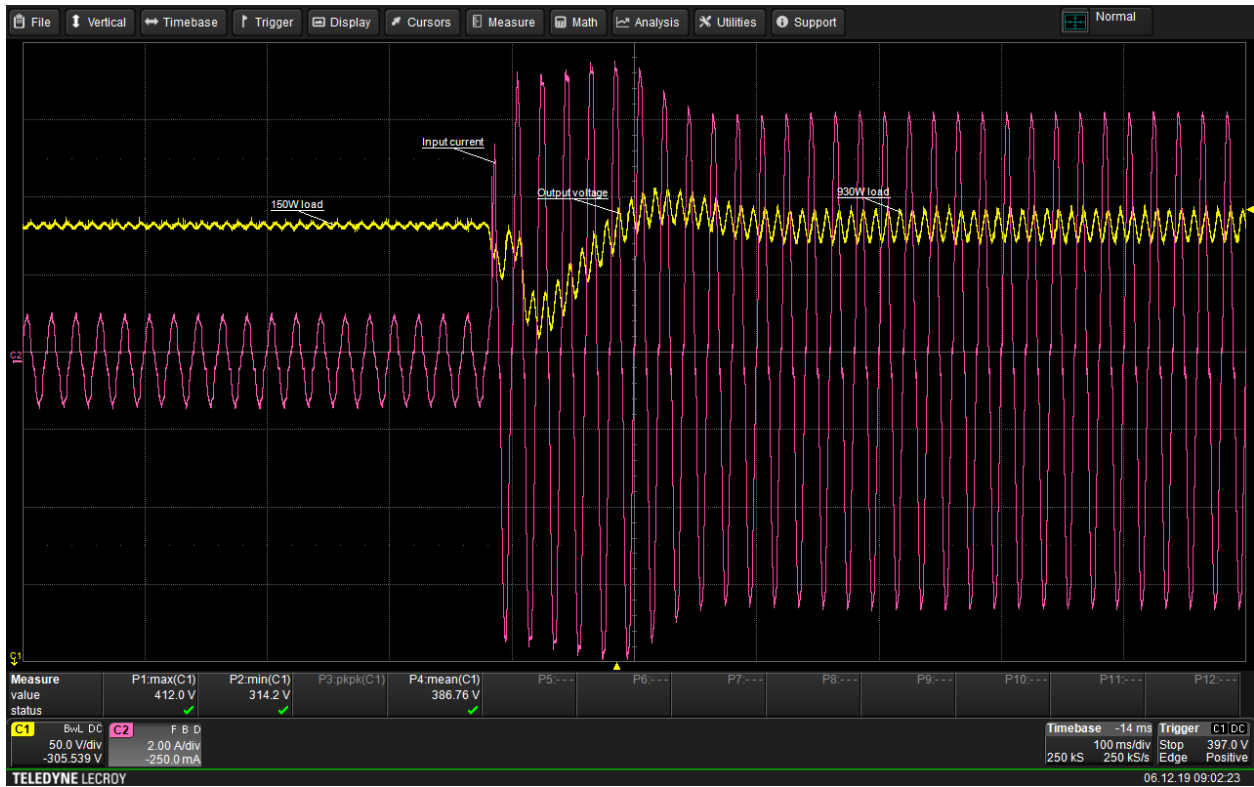

Figure 10. Load Transient 155 W to 930 W at 230 V AC Input

EVBUM2775/D

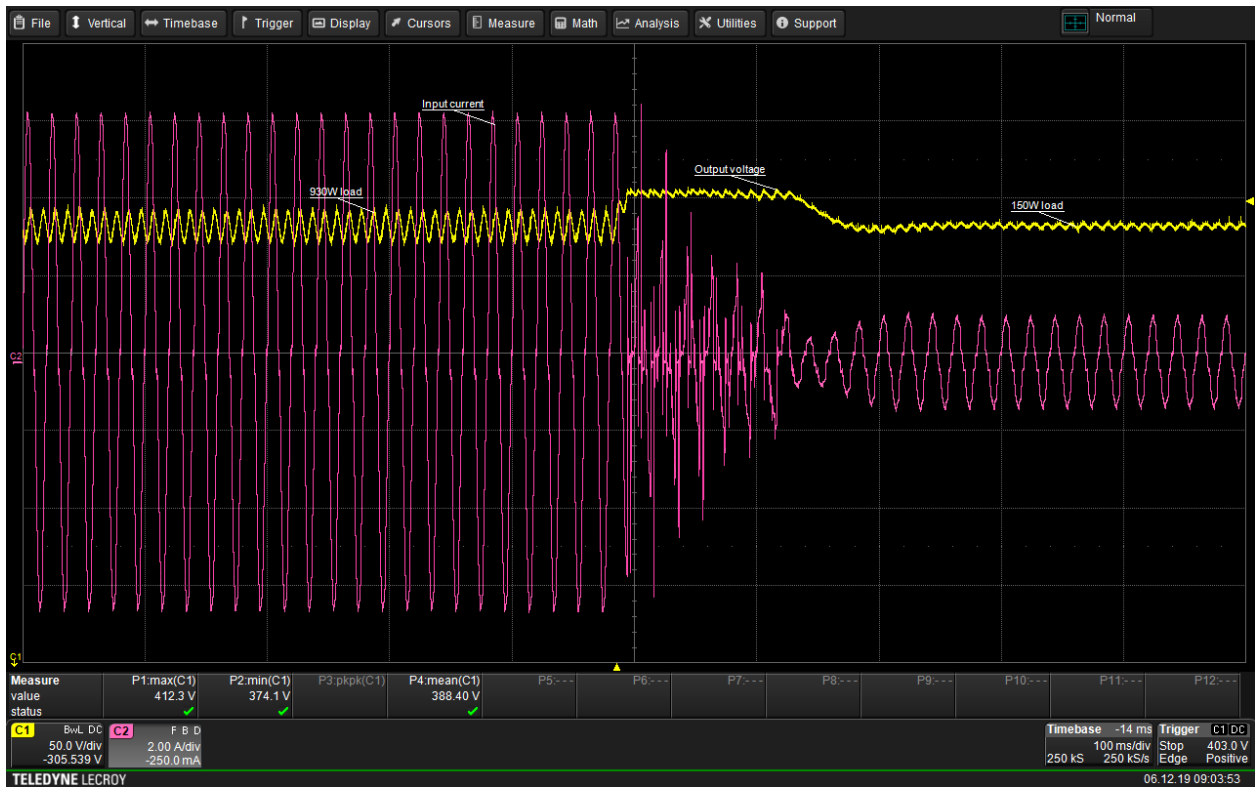

Figure 11. Load Transient 930 W to 155 W at 230 V AC Input



Figure 12. Start up to Open Circuit, 155 W and 930 W at 230 V AC Input

EVBUM2775/D

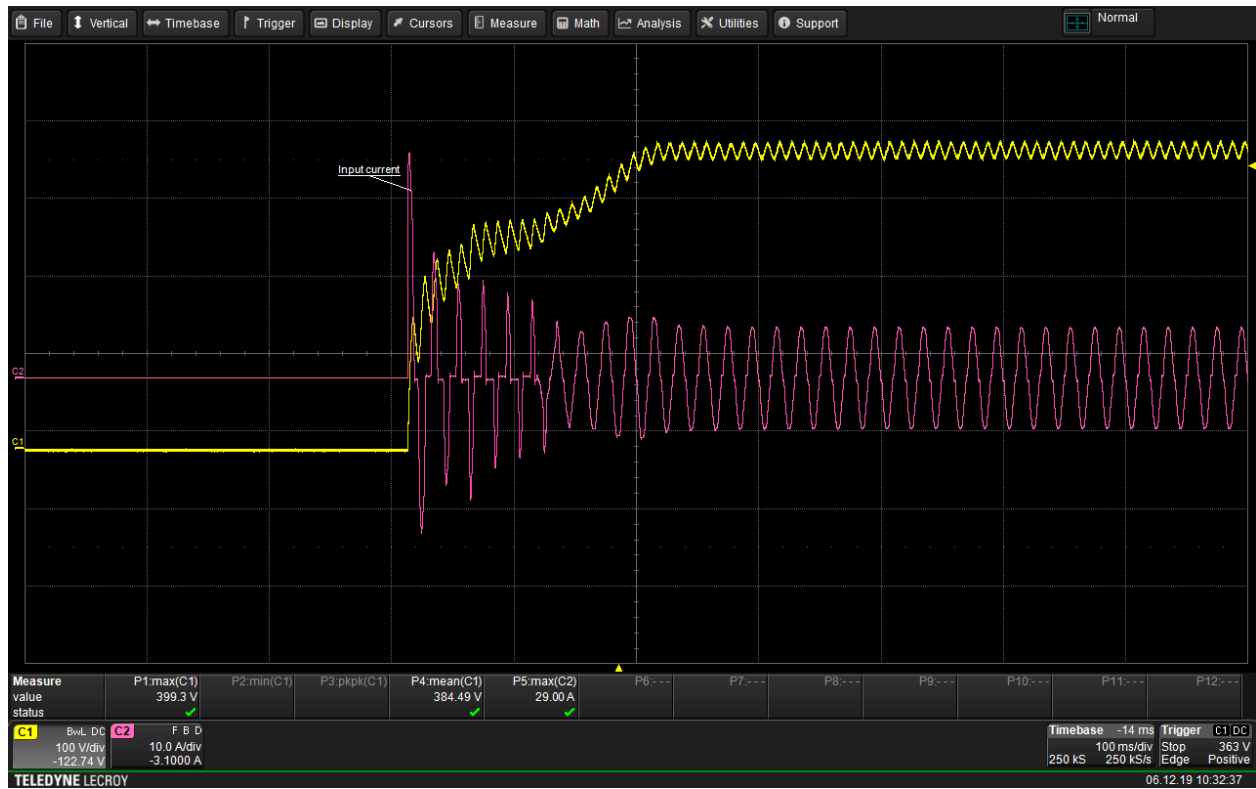

Figure 13. Start to 930 W at 230 V AC Input, Inrush Current

EVBUM2775/D

Auxiliary 15 V Power Supply

The NCP1063 is used as converter 390 V to 15 V output to supply PFC, IPM and Control board (Arduino Due). The maximal power delivered is up to 4.6 W. Figure 14 depicts

schematic of 15 V auxiliary power supply. Figure 15 shows startup of the converter.

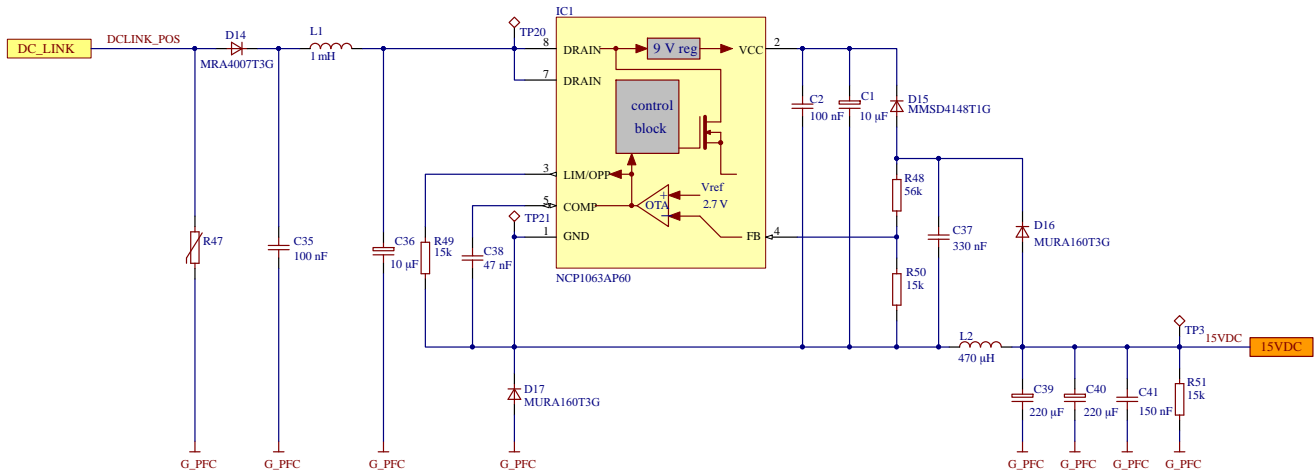

Figure 14. Schematic of Auxiliary 15V Power Supply

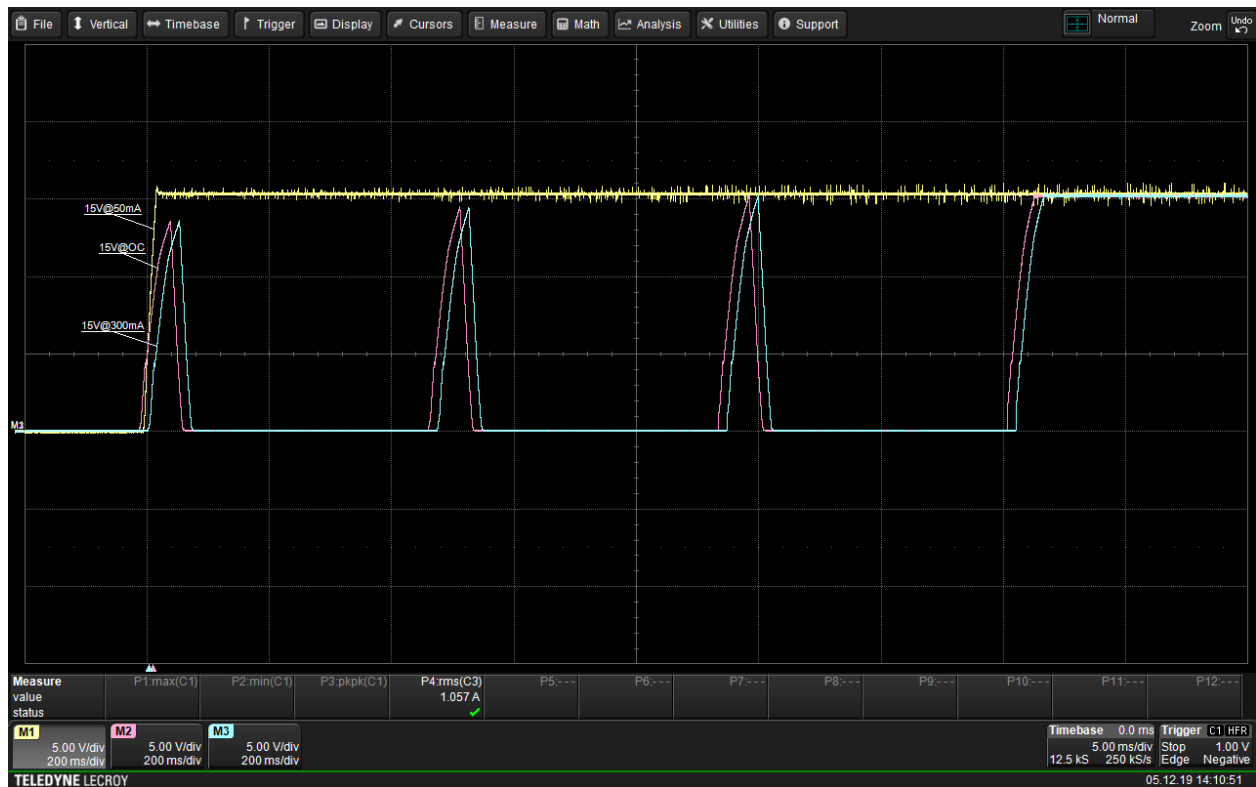

Figure 15. Start Up to Open Circuit, to 50 mA and to 300 mA at 390 V DC Input

IPM Stage

This stage uses NFAQ1060L36T IPM for 3-phase motor drives containing three-phase inverter, gate drivers for the inverter and a thermistor. It uses ON Semiconductor's Insulated Metal Substrate (IMS) Technology. Very important function is over-current protection which is deeply described in chapter – Current Measurement and Over-Current Protection. Module also contains fault pin

which is keeping high level during normal state. *Activation of IPM stage (connection to 15 V DC power supply) is via J1 (soldered pads).* In the figure 15 is shown schematics of IPM stage also with DC link voltage measurement (voltage divider containing R46, R52, R53 and R55). Signals from 39 mΩ shunt resistors are going to current measurement and over-current protection circuits.

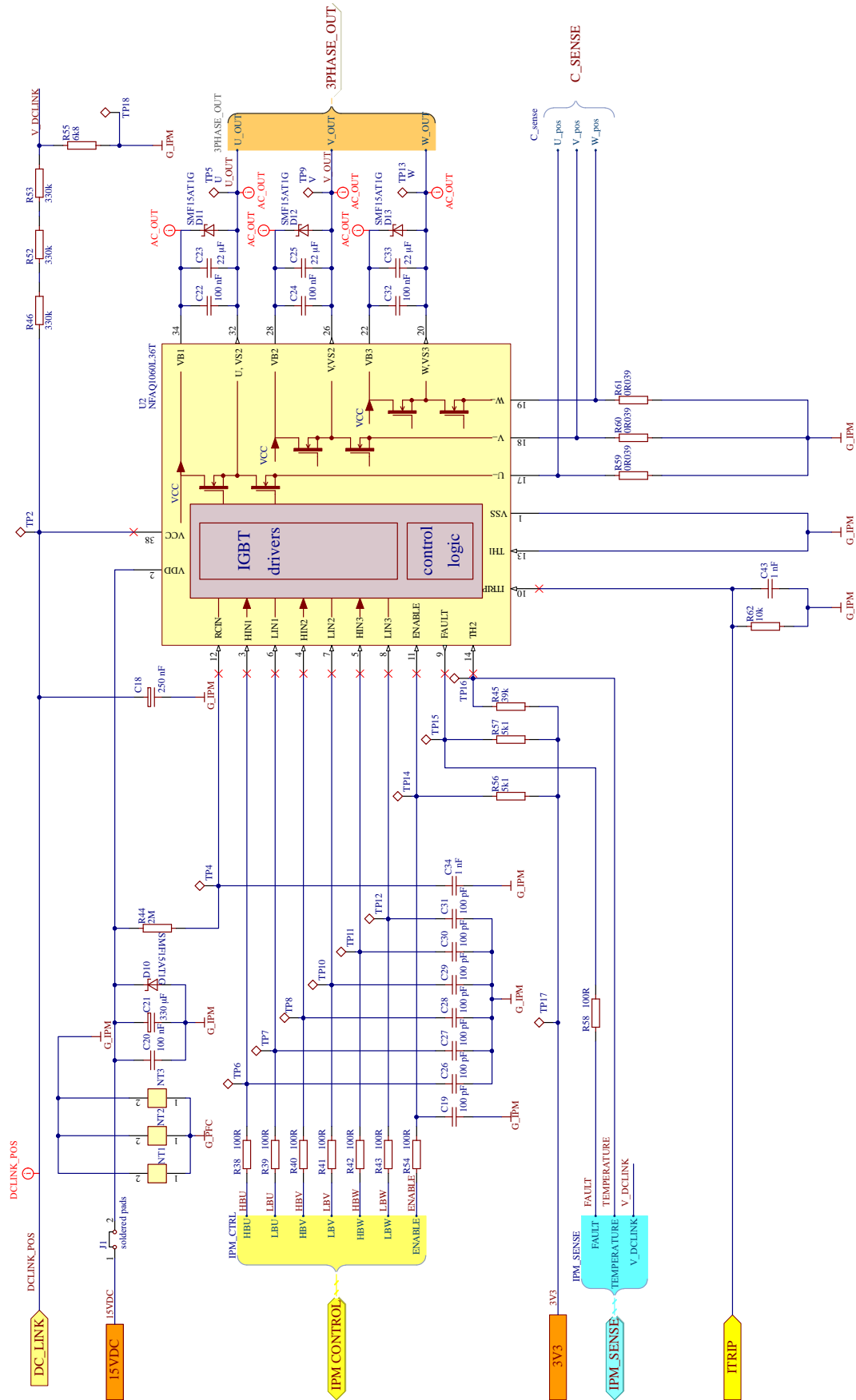

Figure 16. Schematic of IPM Stage

Current Measurement and Over-Current Protection

Schematic of current measurement and over-current protection can be seen in the Figure 17. Information about currents is provided via 39 mΩ shunt resistors. Voltage drop from shunt resistor is going to input of operational amplifier (op-amp) NCS2003 which gain is set to 4.99 with 1k resistor and 4k99 resistor connected as negative feedback. U7 (TLV431) is creating 1.65 V reference which is connected to non-inverting input of op-amps. This connection provides voltage offset at the output of op-amps, which is needed for negative current measurement.

Overcurrent protection is offered by NCS2250 comparator. Comparator threshold is set by voltage divider which consists of R68, R71 and C48. Signals from shunt resistors are going via R78, R81 and R84 connected to non-inverting input. These resistors together with C58 are also acting as low pass filter for high frequency signals interference. On the one hand, with insufficient filtering the over-current protection can react for lower values of current even if there is 350 ns blanking time on ITRIP pin of IPM to improve noise immunity (see datasheet of IPM). On the other hand, when we are designing this filter it is needed to

be careful about the maximal time constant value according short circuit safe operating area (see datasheet of IPM, NFAQ1060L36T- for $V_{CE} = 400\text{ V}$ is 4 μs). Output from comparator is connected to ITRIP pin of IMP module. As was mentioned in previous chapter, IPM has fault pin and its voltage level is high during normal state. An over-current condition is detected if the voltage on the ITRIP pin is larger than the reference voltage (typically 0.5 V). After a shutdown propagation delay of typically 1.1 μs , the FAULT output is switched on. The FAULT output is held on for a time determined by the resistor and capacitor connected to the RCIN pin (IPM pin 12). If $R44 = 2\text{ M}\Omega$ and $C34 = 1\text{ nF}$, the FAULT output is switched on for 1.65 ms (typical). The over-current protection threshold should be set to be equal or lower to 2 times the module rated current. The reaction of the protection can be seen in the Figure 18 and 19. System is also using ENABLE pin of the IPM. After the over-current fault, fault signal is generated and sent to microcontroller which disable the IPM via ENABLE pin (programmed by user). New operation is possible after microcontroller reset.

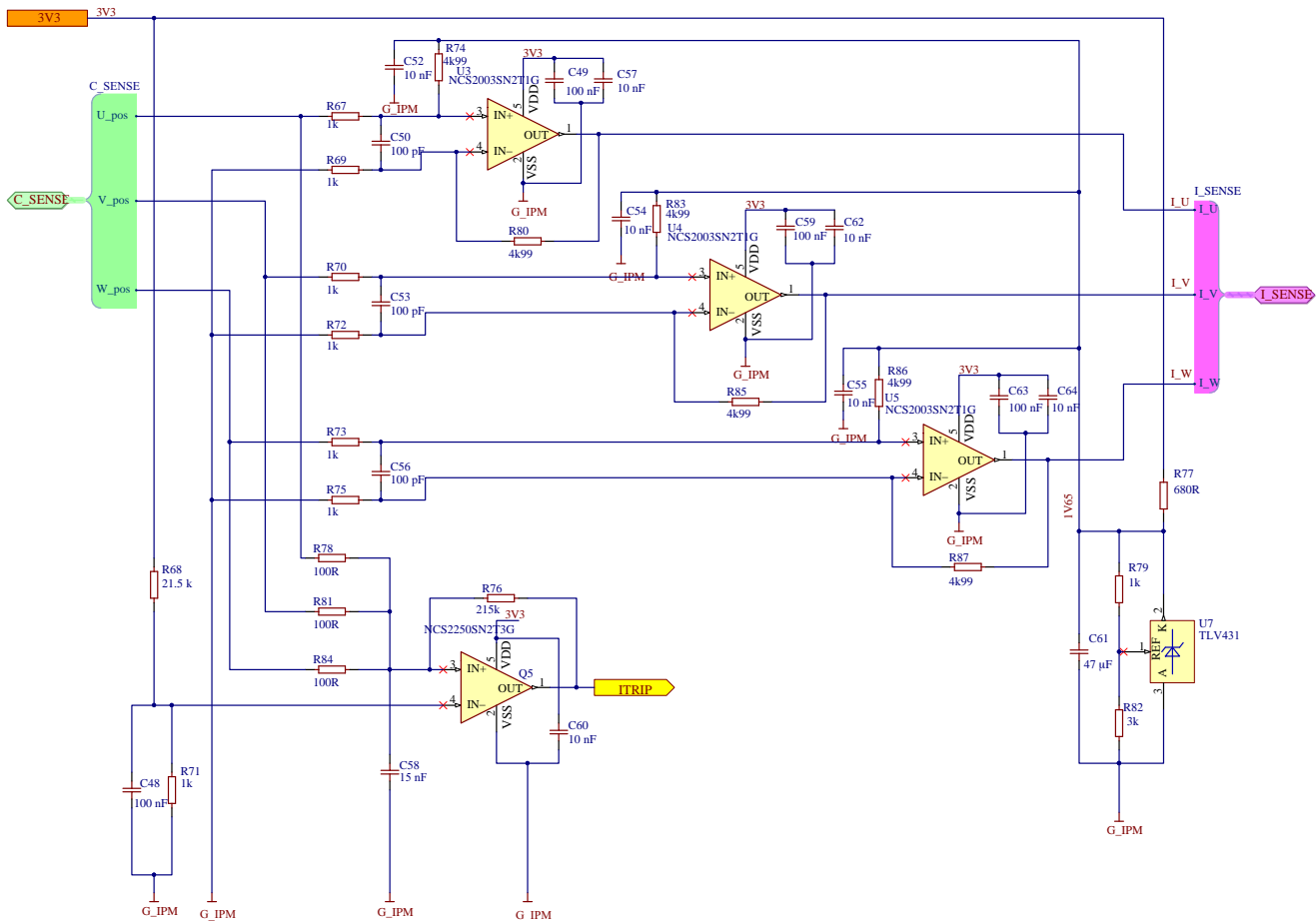

Figure 17. Schematic of Current Measurement and Overcurrent Protection

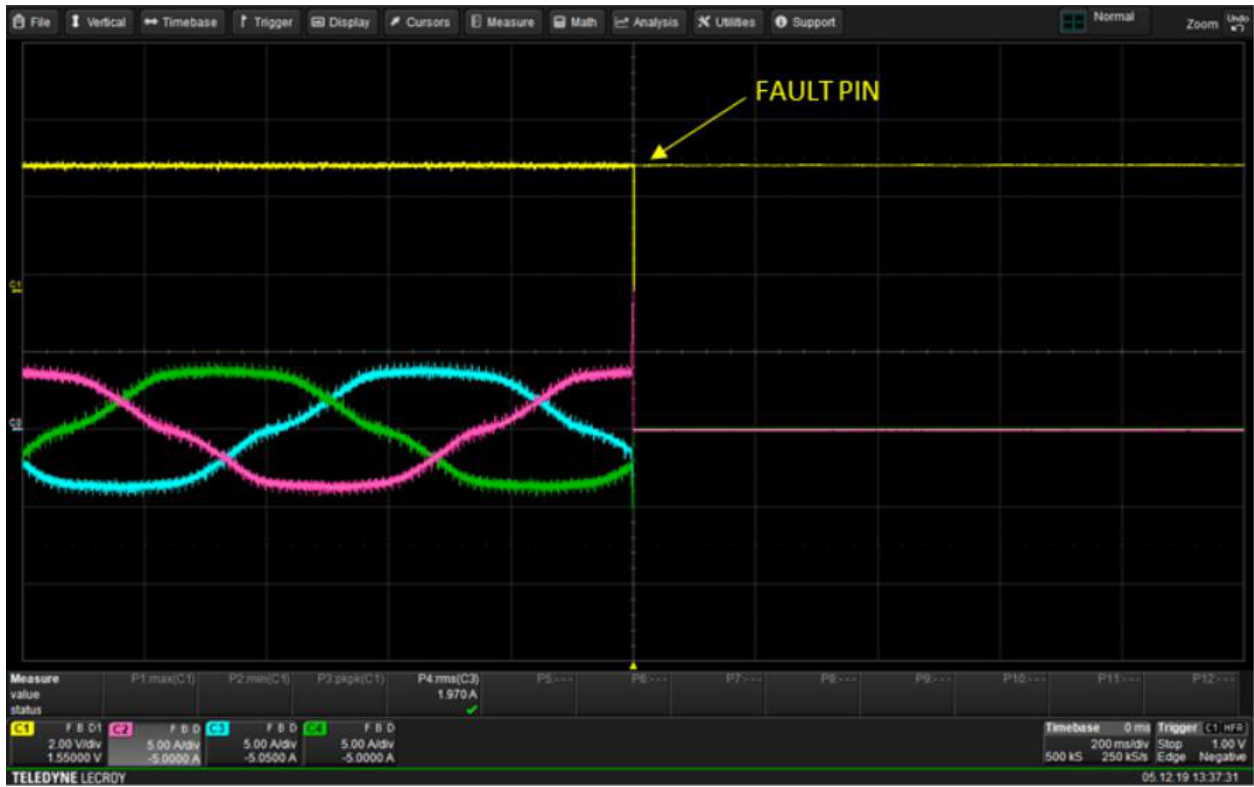

Figure 18. Reaction of Over-current Protection

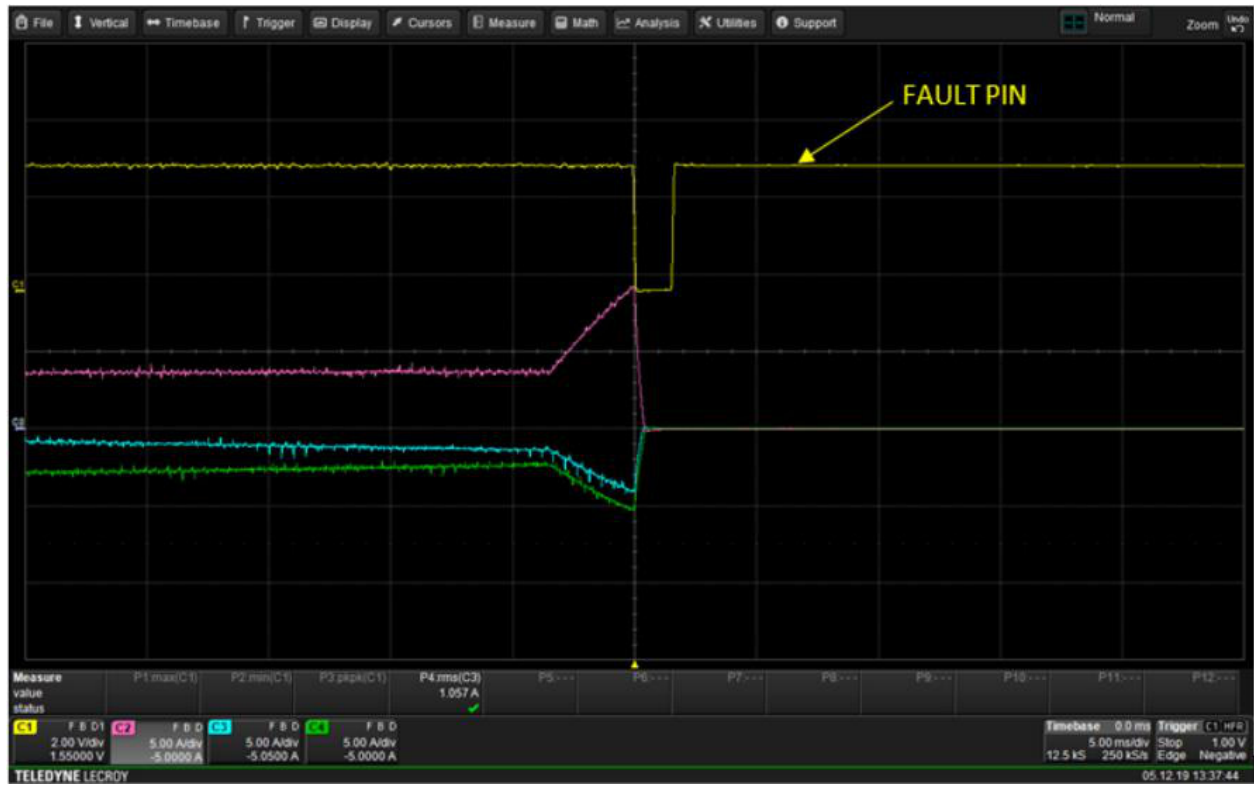

Figure 19. Reaction of Over-current Protection – Detail

EVBUM2775/D

Control Board Headers

Schematic of control board headers can be seen in the Figure 20. The headers have Arduino Due footprint. The applied control board has to contain 3V3 power supply as it is also used for supplying current measurement op amps and

comparator for over-current protection. Low pass filters for current and voltage measurement signals are placed closed to the headers (see CON4). *When connecting the control board to the PC, do not forget to use isolator.*

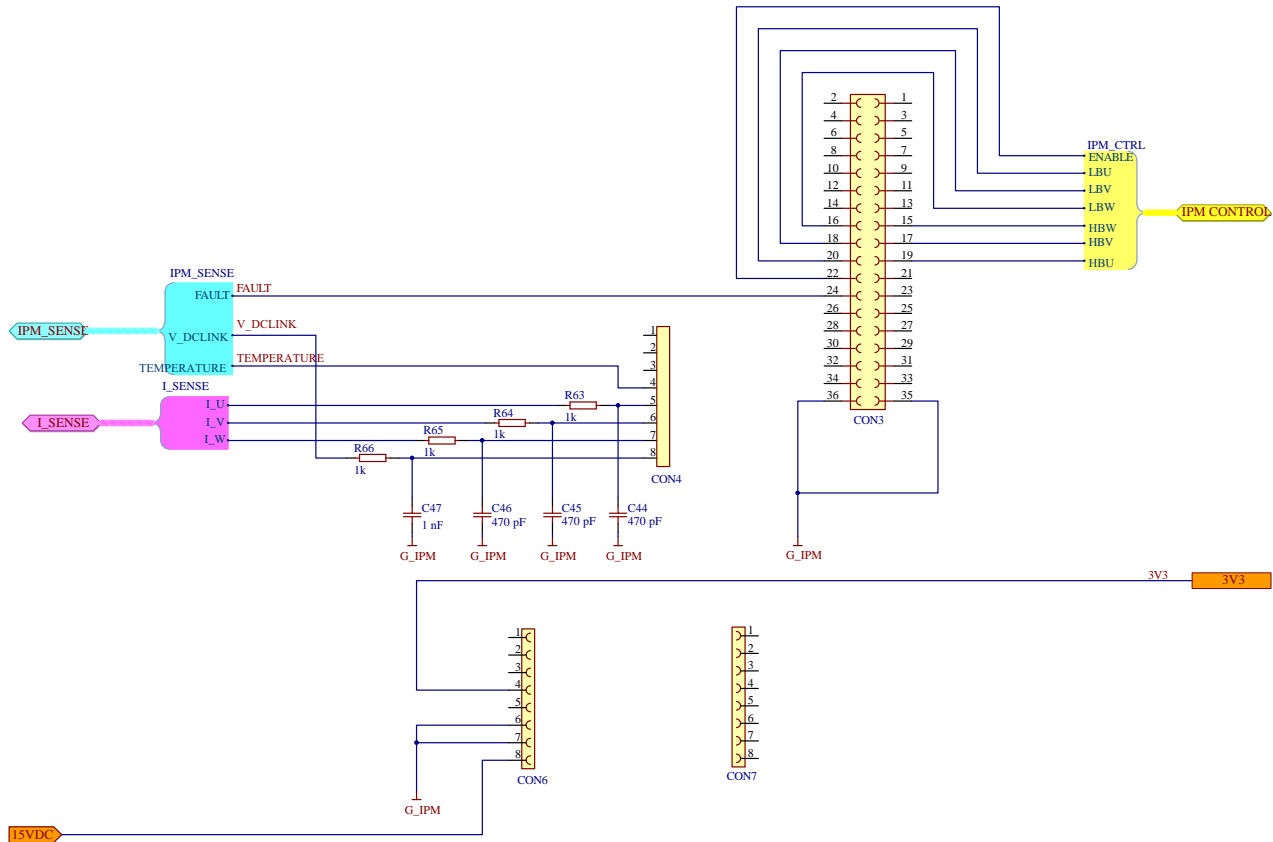

Figure 20. Schematic of Control Board Headers

Layout

Evaluation board consist of 4 layers. Following figures are showing all the layers. Board size is 280x112 mm.

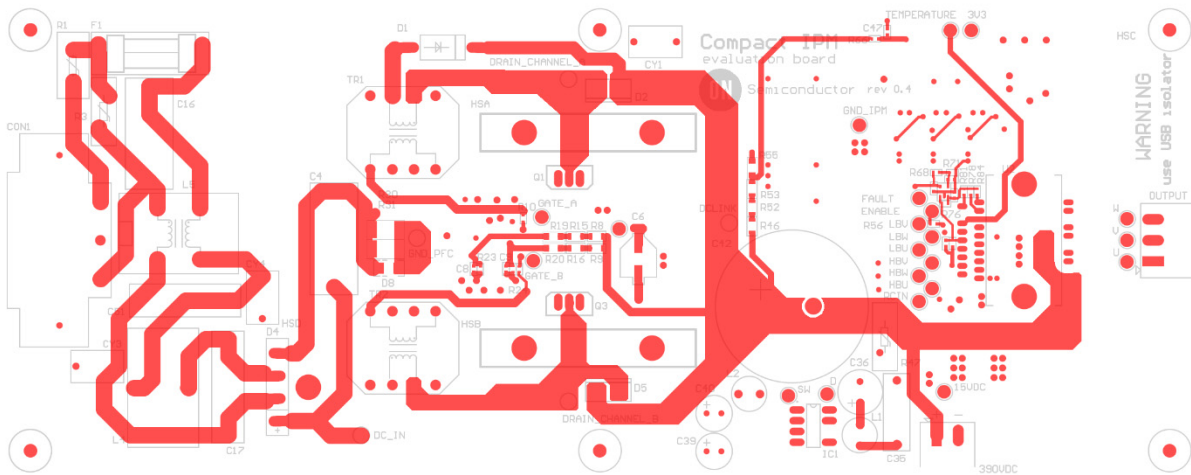

Figure 21. Top Layer Routing and Top Assembly

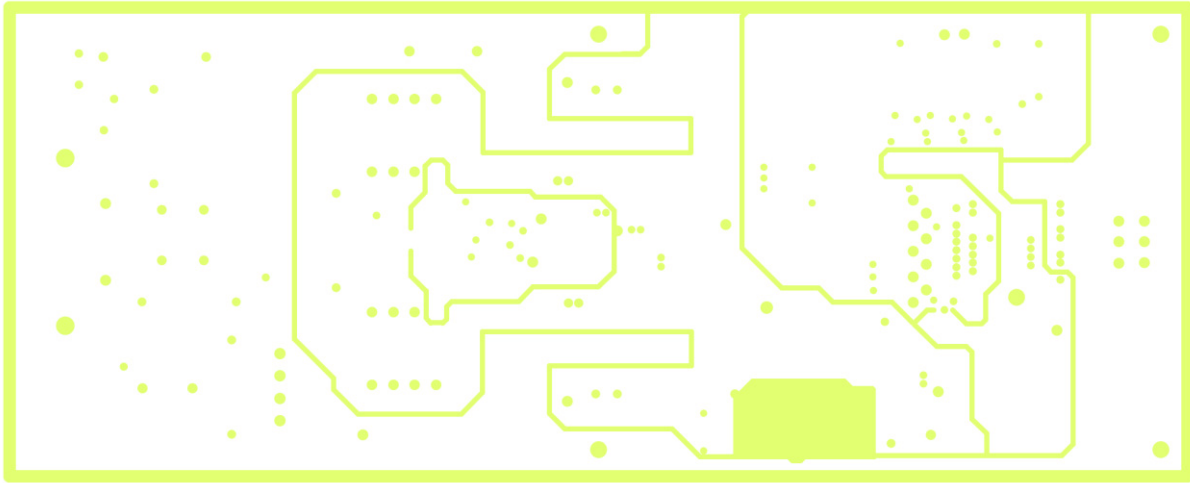

Figure 22. Internal Layer 1

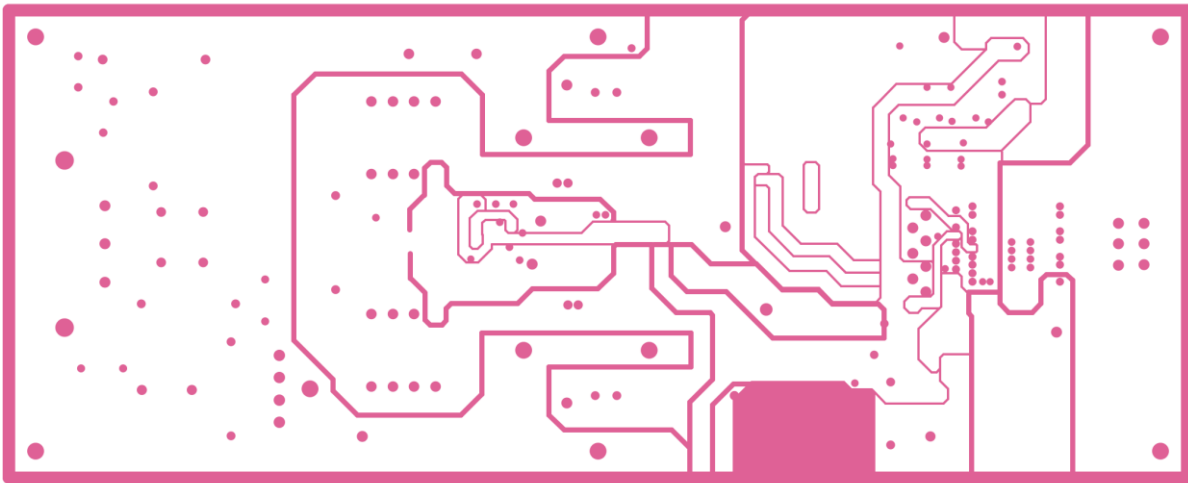

Figure 23. Internal Layer 2

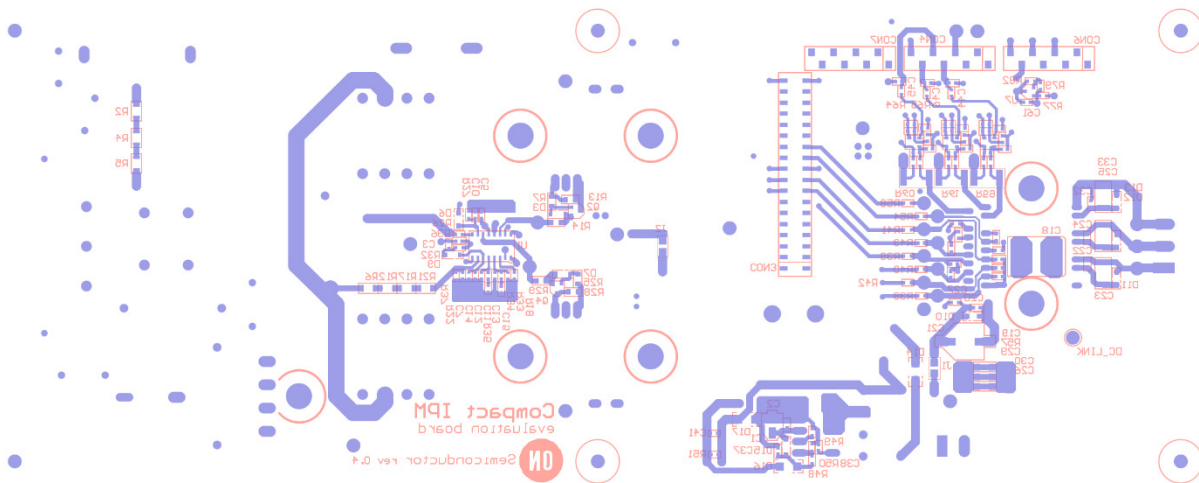

Figure 24. Bottom Layer Routing and Bottom Assembly

EVBUM2775/D

Electromagnetic Compatibility

Due to the inherent high frequency common mode noise generated by the power switches, it is strongly recommended to install a ferrite clamp on the motor wires.

This will prevent disturbing other electronic devices in the vicinity, including the UCB.

The recommended CM filter setup is depicted in the picture below.

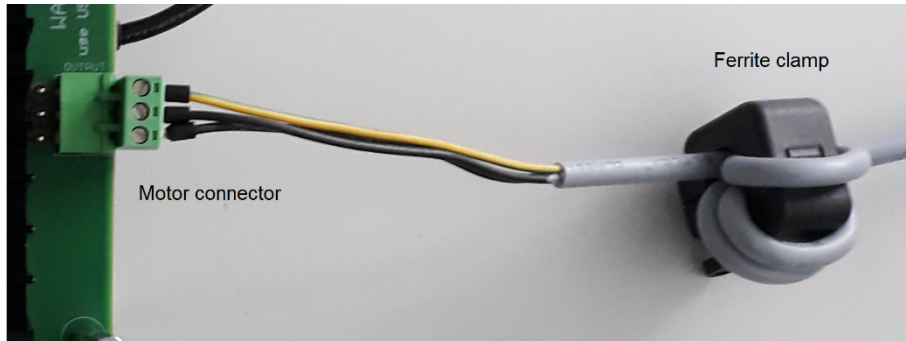

Figure 25. Recommended EMC Filter

EVBUM2775/D

Bill of Materials

Table 3 provides bill of materials of the evaluation board.

Table 3. BILL OF MATERIALS OF THE EVALUATION BOARD

No.	Designator	Comment	Manufacturer	Part number	Quantity
1.	C1	10 μ F	Würth Elektronik	865080540004	1
2.	C2	100 nF	Würth Elektronik	885012206071	1
3.	C3, C5	100 nF	Würth Elektronik	885012206095	2
4.	C4, C16	1 μ F	Würth Elektronik	890334026027CS	2
5.	C6	100 μ F	Würth Elektronik	875115652007	1
6.	C7	330 nF	Murata	GRM188R71C334JA01D	1
7.	C8, C9	1 nF	Würth Elektronik	885012006044	2
8.	C10, C52, C54, C55, C57, C62, C64	10 nF	Würth Elektronik	885012206089	7
9.	C11	2 μ 2	Würth Elektronik	885012206027	1
10.	C12	220 nF	Murata	GRM188R71H224KAC4D	1
11.	C13	68 pF	Murata	GRM1885C1H680JA01D	1
12.	C14	470 nF	Murata	GRM188R61H474KA12D	1
13.	C15	1 nF	Würth Elektronik	885012006063	1
14.	C17, C51	680 nF	Würth Elektronik	890334026020CS	2
15.	C18	250 nF	TDK	B5803119254M062	1
16.	C19, C26, C27, C28, C29, C30, C31, C50, C53, C56	100 pF	Würth Elektronik	885012006057	10
17.	C20	100 nF	Würth Elektronik	885012207072	1
18.	C21	330 μ F	Würth Elektronik	875075661010	1
19.	C22, C24, C32	100 nF	Würth Elektronik	885012105018	3
20.	C23, C25, C33	22 μ F	TDK	C4532X7R1E226M250KC	3
21.	C34, C43, C47	1 nF	Würth Elektronik	885012206083	3
22.	C35	100 nF	Würth Elektronik	890334025017CS	1
23.	C36	10 μ F	Rubycon	450BXF10M10X16	1
24.	C37	330 nF	Würth Elektronik	885012207101	1
25.	C38	47 nF	Würth Elektronik	885012206093	1
26.	C39, C40	220 μ F	Würth Elektronik	860040474004	2
27.	C41	150 nF	Murata	GRM188R71H154KAC4D	1
28.	C42	470 μ F	Würth Elektronik	861141486024	1
29.	C44, C45, C46	470 pF	Würth Elektronik	885012006061	3
30.	C48, C49, C59, C63	100 nF	Würth Electronics	885012206046	4
31.	C58	15 nF	Würth Elektronik	885012206090	1
32.	C60	10 nF	Würth Elektronik	885012206065	1
33.	C61	47 μ F	Murata	GRM188R60J476ME15D	1
34.	CON1	Black	TE Connectivity	6ESRM-P	1
35.	CON2	Green	Würth Elektronik	691313710003	1
36.	CON3	610 036 218 21	Würth Elektronik	61003621821	1

EVBUM2775/D

Table 3. BILL OF MATERIALS OF THE EVALUATION BOARD

No.	Designator	Comment	Manufacturer	Part number	Quantity
37.	CON4, CON6, CON7	610 008 13 321	Würth Elektronik	61000813321	3
38.	CON5	691 313 510 002	Würth Elektronik	691313510002	1
39.	CY1, CY3, CY4	4700 pF	Murata	DE1E3KX472MA4BN01F	3
40.	D1	1N5406RLG	ON Semiconductor	1N5406RLG	1
41.	D2, D5	FFSPF1065A	ON Semiconductor	FFSPF1065A	2
42.	D3, D7, D9, D15	MMSD4148T1G	ON Semiconductor	MMSD4148T1G	4
43.	D4	GBU6K	ON Semiconductor	GBU6K	1
44.	D6, D10, D11, D12, D13	SMF15AT1G	ON Semiconductor	SMF15AT1G	5
45.	D8	NTSS3100	ON Semiconductor	NTSS3100T3G	1
46.	D14	MRA4007T3G	ON Semiconductor	MRA4007T3G	1
47.	D16, D17	MURA160T3G	ON Semiconductor	MURA160T3G	2
48.	F1	10 A	Schurter	0031.8201	1
49.	F2	4 A	Schurter	0034.3123	1
50.	FC1	Fuse cover	Schurter	0853.0551	1
51.	HSA, HSB	SK 489 50 mm black anodized			2
52.	HSC	SK 92 30 mm natural anodized			1
53.	HSD	SK 447 37.5 mm black anodized			1
54.	IC1	NCP1063AP60	ON Semiconductor	NCP1063AP60G	1
55.	J_AC_OUT	691 351 500 003	Würth Elektronik	691351500003	1
56.	J_DC390V	691 351 500 002	Würth Elektronik	691351500002	1
57.	L1	1 mH	Würth Elektronik	744731102	1
58.	L2	470 μ H	Würth Elektronik	744731471	1
59.	L4	150 μ H	Würth Elektronik	7447076	1
60.	L5	2 x 2.2 mH	Würth Elektronik	744824622	1
61.	NAC1, NAC2	nut M3 ISO4032			2
62.	Q1, Q3	FCPF125N65S3	ON Semiconductor	FCPF125N65S3	2
63.	Q2, Q4	MMBT589LT1G	ON Semiconductor	MMBT589LT1G	2
64.	Q5	NCS2250SN2T3G	ON Semiconductor	NCS2250SN2T3G	1
65.	R1	2R2	TDK	B57237S0229M000	1
66.	R2, R4, R5	680k	Vishay	CRCW1206680KFKEA	3
67.	R3, R47	320 V	TDK	B72214S0321K101	2
68.	R6, R12, R17, R21	3M9	Vishay	CRCW12063M90FKEA	4
69.	R7, R25	10R	Panasonic	ERJ6ENF10R0V	2
70.	R8, R9, R15, R16	1M8	Vishay	CRCW12061M80FKEA	4
71.	R10, R11, R32, R36	22k	Panasonic	ERJ3EKF2202V	4
72.	R13, R28	10k	Panasonic	ERJ6ENF1002V	2
73.	R14, R29	0R	Panasonic	ERJ6GEY0R00V	2
74.	R18	11k5	Panasonic	ERJ3EKF1152V	1

EVBUM2775/D

Table 3. BILL OF MATERIALS OF THE EVALUATION BOARD

No.	Designator	Comment	Manufacturer	Part number	Quantity
75.	R19	820k	Panasonic	ERJU08F8203V	1
76.	R20	560k	Panasonic	ERJU08F5603V	1
77.	R22	120k	Panasonic	ERJ3EKF1203V	1
78.	R23, R24	27k	Panasonic	ERJ3EKF2702V	2
79.	R26	1k8	Panasonic	ERJ3EKF1801V	1
80.	R27, R63, R64, R65, R71, R79	1k	Panasonic	ERJ3EKF1001V	6
81.	R30, R31	0R075	Bourns	CRA2512-FZ-R075ELF	2
82.	R33	270k	Panasonic	ERJ3EKF2703V	1
83.	R34, R56, R57	5k1	Panasonic	ERJ3EKF5101V	3
84.	R35, R49, R50, R51	15k	Panasonic	ERJ3EKF1502V	4
85.	R37	143k	Panasonic	ERJ3EKF1433V	1
86.	R38, R39, R40, R41, R42, R43, R54, R58, R78, R81, R84	100R	Panasonic	ERJ3EKF1000V	11
87.	R44	2M	Vishay	CRCW06032M00FKEA	1
88.	R45	39k	Panasonic	ERJ3EKF3902V	1
89.	R46, R52, R53	330k	Vishay	CRCW1206330KFKEA	3
90.	R48	56k	Panasonic	ERJ3EKF5602V	1
91.	R55	6k8	Panasonic	ERJP08F6801V	1
92.	R59, R60, R61	0R039	KOA SPEER ELECTRONICS	TLRH3AWTTE39L0F	3
93.	R62	10k	Panasonic	ERJ3EKF1002V	1
94.	R66, R67, R69, R70, R72, R73, R75	1k	Panasonic	ERJ3RBD1001V	7
95.	R68	21k5	Panasonic	ERJ3EKF2152V	1
96.	R74, R80, R83, R85, R86, R87	4k99	TT Electronics	PCF0603R-4K99BT1	6
97.	R76	215k	Panasonic	ERJ3EKF2153V	1
98.	R77	680R	Panasonic	ERJ3EKF6800V	1
99.	R82	3k	Panasonic	ERJ3EKF3001V	1
100.	SAC1, SAC2, SHA1, SHA2, SHB1, SHB2, SHD1	M3x8 DIN7985			7
101.	SB1, SB2, SB3, SB4, SB5, SB6	Spacer M3 F/F 50 HEX7			6
102.	SDA, SDB, SDD, SHC1, SHC2, SQA, SQB	M3x16 DIN7985			7
103.	SHSA1, SHSA2, SHSB1, SHSB2	spacer for M3	Würth Elektronik	963030042	4
104.	ST1, ST2, ST3, ST4, ST5, ST6	Spacer M3 M/F 6/30 HEX7			6
105.	TP1, TP2	RED	Keystone Electronics	5005	2

EVBUM2775/D

Table 3. BILL OF MATERIALS OF THE EVALUATION BOARD

No.	Designator	Comment	Manufacturer	Part number	Quantity
106.	TP3, TP17, TP24	ORANGE	Keystone Electronics	5008	3
107.	TP4, TP18, TP21	WHITE	Keystone Electronics	5007	3
108.	TP5, TP9, TP13, TP22	BROWN	Keystone Electronics	5120	4
109.	TP6, TP7, TP8, TP10, TP11, TP12, TP14, TP25, TP26	YELLOW	Keystone Electronics	5009	9
110.	TP15, TP16	BLUE	Keystone Electronics	5122	2
111.	TP20, TP23, TP28	PURPLE	Keystone Electronics	5124	3
112.	TP27	BLACK	Keystone Electronics	5006	1
113.	TR1, TR2	750314724	Würth Elektronik	750314724	2
114.	U1	NCP1632	ON Semiconductor	NCP1632DR2G	1
115.	U2	NFAQ1060L36T	ON Semiconductor	NFAQ1060L36T	1
116.	U3, U4, U5	NCS2003SN2T1G	ON Semiconductor	NCS2003SN2T1G	3
117.	U7	TLV431	ON Semiconductor	TLV431CSN1T1G	1
118.	WAC1, WAC2, WHSA1, WHSA2, WHSB1, WHSB2, WPDA, WPDB, WPDD, WPQA, WPQB, WSHC1, WSHC2, WSHD1	plain washer M3 DIN125A			14
119.	WHAD, WHAQ, WHBD, WHBQ	AOS 220 18x12x1.5 D3.1			4
120.	WSDA, WSDB, WSDD, WSQA, WSQB	spring washer M3 DIN7980			5

Table 4. BILL OF MATERIALS OF THE UCB ADAPTER

No.	Designator	Comment	Manufacturer	Part number	Quantity
1.	C1	10uF, 50V	Würth Elektronik	885012108022	1
2.	C2, C11, C12	10uF, 10V	Würth Elektronik	885012107010	3
3.	C3	100uF, 25V	Würth Elektronik	865080449011	1
4.	C4, C5	100nF, 16V	Würth Elektronik	885012206046	2
5.	C15, C21	10nF, 50V	Würth Elektronik	885012206089	2
6.	C16	470nF, 50V	Würth Elektronik	885012207102	1
7.	C19, C20	22uF, 10V	Würth Elektronik	885012209006	2
8.	C23	470pF, 50V	Würth Elektronik	885012006061	1
9.	D1, D2, D3, D4, D5, D6, D7, D8, D9, D10	BAT54S	ON Semiconductor	BAT54S	10
10.	D11, D12	MBR230LSFT1G	ON Semiconductor	MBR230LSFT1G	2
11.	D13	MBRS2040LT3G	ON Semiconductor	MBRS2040LT3G	1
12.	J1	61001011921	Würth Elektronik	61001011921	1
13.	J2, J3, J5, J6, J7	61000811921	Würth Elektronik	61000811921	5
14.	J4	61003621821	Würth Elektronik	61003621821	1

EVBUM2775/D

Table 4. BILL OF MATERIALS OF THE UCB ADAPTER

No.	Designator	Comment	Manufacturer	Part number	Quantity
15.	J8	61000621821	Würth Elektronik	61000621821	1
16.	J9	694106105102	Würth Elektronik	694106105102	1
17.	JB1, JB2	10139781-121402LF	Amphenol	10139781-121402LF	2
18.	L1	22uH, 3A	Würth Elektronik	7447714220	1
19.	R1, R6	0R			2
20.	R3	0R			1
21.	R4	270R			1
22.	R5	560R			1
23.	R7, R8	470R			2
24.	R45	22k			1
25.	R46	3k			1
26.	R47	56k			1
27.	U1	FAN8303MX	ON Semiconductor	FAN8303MX	1
28.	U2	NCP1117ST33T3G	ON Semiconductor	NCP51460SN33T1G	1
29.	U3	NCP1117ST50T3G	ON Semiconductor	NCP1117ST50T3G	1
30.	C1	10uF, 50V	Würth Elektronik	885012108022	1
31.	C2, C11, C12	10uF, 10V	Würth Elektronik	885012107010	3
32.	C3	100uF, 25V	Würth Elektronik	865080449011	1
33.	C4, C5	100nF, 16V	Würth Elektronik	885012206046	2
34.	C15, C21	10nF, 50V	Würth Elektronik	885012206089	2
35.	C16	470nF, 50V	Würth Elektronik	885012207102	1
36.	C19, C20	22uF, 10V	Würth Elektronik	885012209006	2
37.	C23	470pF, 50V	Würth Elektronik	885012006061	1
38.	D1, D2, D3, D4, D5, D6, D7, D8, D9, D10	BAT54S	ON Semiconductor	BAT54S	10
39.	D11, D12	MBR230LSFT1G	ON Semiconductor	MBR230LSFT1G	2
40.	D13	MBRS2040LT3G	ON Semiconductor	MBRS2040LT3G	1
41.	J1	61001011921	Würth Elektronik	61001011921	1
42.	J2, J3, J5, J6, J7	61000811921	Würth Elektronik	61000811921	5
43.	J4	61003621821	Würth Elektronik	61003621821	1
44.	J8	61000621821	Würth Elektronik	61000621821	1
45.	J9	694106105102	Würth Elektronik	694106105102	1
46.	JB1, JB2	10139781-121402LF	Amphenol	10139781-121402LF	2
47.	L1	22uH, 3A	Würth Elektronik	7447714220	1
48.	R1, R6	0R			2
49.	R3	0R			1
50.	R4	270R			1
51.	R5	560R			1
52.	R7, R8	470R			2
53.	R45	22k			1
54.	R46	3k			1
55.	R47	56k			1
56.	U1	FAN8303MX	ON Semiconductor	FAN8303MX	1
57.	U2	NCP1117ST33T3G	ON Semiconductor	NCP51460SN33T1G	1
58.	U3	NCP1117ST50T3G	ON Semiconductor	NCP1117ST50T3G	1

GRAPHICAL USER INTERFACE

Open loop operation (V/F)

In order to facilitate fast evaluation of the power stage, the user can select open loop operation option within the GUI menu.

FOC closed loop operation

Modern control drives implement the well-known Field Oriented Control (FOC) control-strategy; FOC provides efficient motor-drive for a wide range of motor-speeds, fast dynamic response, a low harmonic content of currents, and reduced losses [8–10].

In general, the implementation of FOC requires at least:

- 1 Timer
- 4 ADC channels (see Note below)
- USART/SPI for communications
- Capture/PWM

FOC should achieve:

- High control bandwidth
- Low current distortion
- Control capability at low speeds

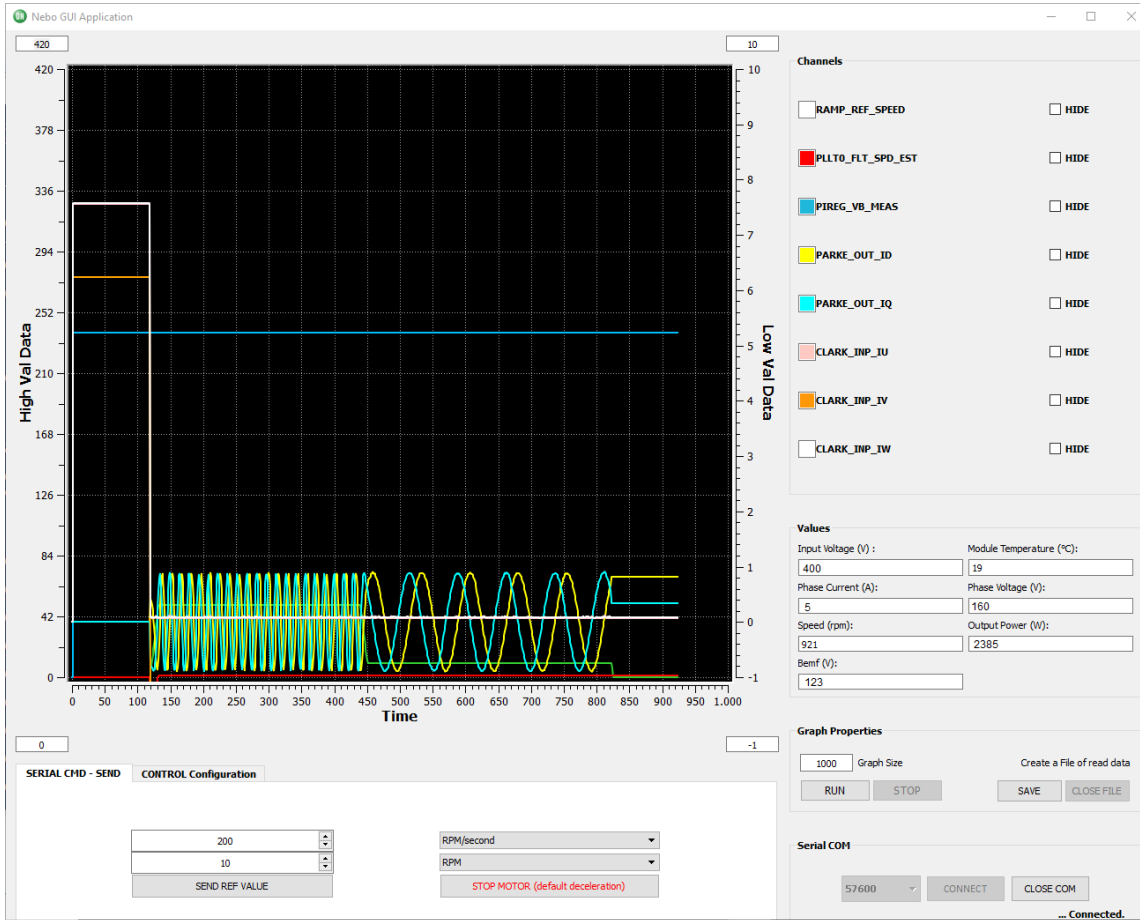

Figure 26. Graphical User Interface for Controlling the Motor in the Open Loop

NOTE: One channel for the voltage level of the VSI H-Bridge, and three channels for the – three – phase currents that flow towards the motor. However, it is possible to implement the FOC strategy with only three ADC channels (two channels for current and one channel for the voltage), as we can measure two-phase currents and mathematically calculate the third one. That implementation requires one shunt-resistor less. Compact IPM, though, comes already with three shunt-resistors.

EVBUM2775/D

During the communication with control board and PC, using of USB isolator is very important because of safety.

In the Figure 27 can be seen evaluation board with USB isolator (5 kV optical isolation).

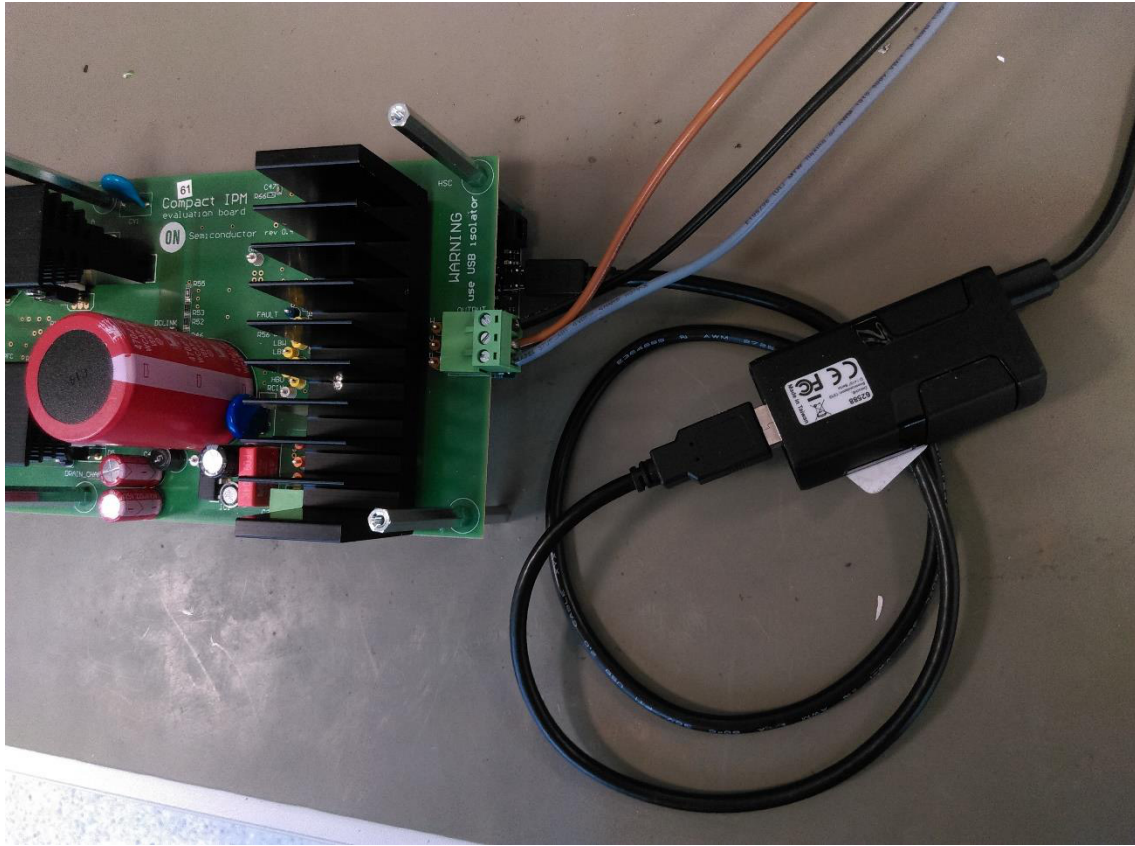

Figure 27. Evaluation Board with Control Board and USB Isolator

REFERENCES

- [1]. Datasheet of IPM NFAQ1060L36T, available on ON Semiconductor website
- [2]. Datasheet of NCP1632, available on ON Semiconductor website
- [3]. Application note – Key Steps to Design an Interleaved PFC Stage Driven by the NCP1632, available on ON Semiconductor website
- [4]. Datasheet of NCP1063, available on ON Semiconductor website
- [5]. Application note – Universal AC Input, 12V 0.35 A Output, 4.2 Watt Non-isolated Power Supply, available on ON Semiconductor website
- [6]. Datasheet of NCS2003, available on ON Semiconductor website
- [7]. Datasheet of NCS2250, available on ON Semiconductor website
- [8]. J.A. Santisteban, R.M. Stephan, “Vector control methods for induction machines: an overview,” *IEEE Transactions on Education*, Vol 44, no 2, pp–170–175, May 2001.
- [9]. M. Ahmad, “High Performance AC Drives: Modelling Analysis and Control,” published by *Springer-Verlag*, 2010.
- [10]. J.R Hendershot, T.J.E. Miller, “Design of Brushless Permanent-Magnet Machines,” published in the USA by *Motor Design Books LLC*, 2010.

ON Semiconductor and the ON Semiconductor logo are trademarks of Semiconductor Components Industries, LLC dba ON Semiconductor or its subsidiaries in the United States and/or other countries. ON Semiconductor owns the rights to a number of patents, trademarks, copyrights, trade secrets, and other intellectual property. A listing of ON Semiconductor's product/patent coverage may be accessed at www.onsemi.com/site/pdf/Patent-Marking.pdf. ON Semiconductor is an Equal Opportunity/Affirmative Action Employer. This literature is subject to all applicable copyright laws and is not for resale in any manner.

The evaluation board/kit (research and development board/kit) (hereinafter the "board") is not a finished product and is as such not available for sale to consumers. The board is only intended for research, development, demonstration and evaluation purposes and should as such only be used in laboratory/development areas by persons with an engineering/technical training and familiar with the risks associated with handling electrical/mechanical components, systems and subsystems. This person assumes full responsibility/liability for proper and safe handling. Any other use, resale or redistribution for any other purpose is strictly prohibited.

The board is delivered "AS IS" and without warranty of any kind including, but not limited to, that the board is production-worthy, that the functions contained in the board will meet your requirements, or that the operation of the board will be uninterrupted or error free. ON Semiconductor expressly disclaims all warranties, express, implied or otherwise, including without limitation, warranties of fitness for a particular purpose and non-infringement of intellectual property rights.

ON Semiconductor reserves the right to make changes without further notice to any board.

You are responsible for determining whether the board will be suitable for your intended use or application or will achieve your intended results. Prior to using or distributing any systems that have been evaluated, designed or tested using the board, you agree to test and validate your design to confirm the functionality for your application. Any technical, applications or design information or advice, quality characterization, reliability data or other services provided by ON Semiconductor shall not constitute any representation or warranty by ON Semiconductor, and no additional obligations or liabilities shall arise from ON Semiconductor having provided such information or services.

The boards are not designed, intended, or authorized for use in life support systems, or any FDA Class 3 medical devices or medical devices with a similar or equivalent classification in a foreign jurisdiction, or any devices intended for implantation in the human body. Should you purchase or use the board for any such unintended or unauthorized application, you shall indemnify and hold ON Semiconductor and its officers, employees, subsidiaries, affiliates, and distributors harmless against all claims, costs, damages, and expenses, and reasonable attorney fees arising out of, directly or indirectly, any claim of personal injury or death associated with such unintended or unauthorized use, even if such claim alleges that ON Semiconductor was negligent regarding the design or manufacture of the board.

This evaluation board/kit does not fall within the scope of the European Union directives regarding electromagnetic compatibility, restricted substances (RoHS), recycling (WEEE), FCC, CE or UL, and may not meet the technical requirements of these or other related directives.

FCC WARNING – This evaluation board/kit is intended for use for engineering development, demonstration, or evaluation purposes only and is not considered by ON Semiconductor to be a finished end product fit for general consumer use. It may generate, use, or radiate radio frequency energy and has not been tested for compliance with the limits of computing devices pursuant to part 15 of FCC rules, which are designed to provide reasonable protection against radio frequency interference. Operation of this equipment may cause interference with radio communications, in which case the user shall be responsible, at its expense, to take whatever measures may be required to correct this interference.

ON Semiconductor does not convey any license under its patent rights nor the rights of others.

LIMITATIONS OF LIABILITY: ON Semiconductor shall not be liable for any special, consequential, incidental, indirect or punitive damages, including, but not limited to the costs of requalification, delay, loss of profits or goodwill, arising out of or in connection with the board, even if ON Semiconductor is advised of the possibility of such damages. In no event shall ON Semiconductor's aggregate liability from any obligation arising out of or in connection with the board, under any theory of liability, exceed the purchase price paid for the board, if any.

For more information and documentation, please visit www.onsemi.com.

PUBLICATION ORDERING INFORMATION

LITERATURE FULFILLMENT:

Email Requests to: orderlit@onsemi.com

ON Semiconductor Website: www.onsemi.com

TECHNICAL SUPPORT

North American Technical Support:

Voice Mail: 1 800-282-9855 Toll Free USA/Canada

Phone: 011 421 33 790 2910

Europe, Middle East and Africa Technical Support:

Phone: 00421 33 790 2910

For additional information, please contact your local Sales Representative