

PB104013-34



PB104014-34



The C60H-DC supplementary protectors are used in direct current circuits (Industrial control and automations, transport, renewable energy...). They combine the following functions of circuit protection against short-circuit and overload currents, control and isolation.

**IEC / EN 60947-2**

**UL1077**

**GB 14048.2**

(Supplementary  
Protector TC 3)



CE

### Catalogue numbers

<b>Operating voltage (Ue)</b>	12...250 V DC	12...500 V DC		
<b>Rated voltage (Un)</b>	250 V DC	500 V DC		
<b>Number of poles</b>	1P	2P		
<b>Curve</b>	C	C		
<b>Number of modules of 9 mm</b>	2	4		
<b>Diagrams</b>	<p>DB116687</p> <p>Supply from above or below, observing the polarity</p>	<p>DB116688</p> <p>Supply from above      Supply from below</p>		
<b>Standards</b>	UL1077	IEC 60947-2 EN 60947-2 GB 14048.2	UL1077	IEC 60947-2 EN 60947-2 GB 14048.2
<b>Breaking capacity</b>	5 kA / 250 V DC	20 kA / 110 V DC 10 kA / 220 V DC 6 kA / 250 V DC	5 kA / 500 V DC	20 kA / 220 V DC 10 kA / 440 V DC 6 kA / 500 V DC
<b>Rating (A)*</b>	<b>UL 1077, IEC 60947-2, EN 60947-2, GB 14048.2</b>			
0.5	MGN61500		MGN61520	
1	MGN61501		MGN61521	
2	MGN61502		MGN61522	
3	MGN61503		MGN61523	
4	MGN61504		MGN61524	
5	MGN61505		MGN61525	
6	MGN61506		MGN61526	
10	MGN61508		MGN61528	
13	MGN61509		MGN61529	
15	MGN61510		MGN61530	
16	MGN61511		MGN61531	
20	MGN61512		MGN61532	
25	MGN61513		MGN61533	
30	MGN61514		MGN61534	
32	MGN61515		MGN61535	
40	MGN61517		MGN61537	
<b>Rating (A)*</b>	<b>IEC 60947-2, EN 60947-2, GB 14048.2</b>			
50	MGN61518		MGN61538	
63	MGN61519		MGN61539	

\* At 25°C / 77°F see temperature derating module 92515.

### Technical data

- Tripping curves: C curve - Overcurrent protection for any type of application.
- Positive break indication - the green strip indicates that all the poles are open and allows work to be carried out on the downstream circuit in complete safety.
- Suitable for isolation as defined in IEC / EN 60947-2.
- Increase in the service life of the product: thanks to fast closure independent of the speed of action on the handle.
- Current limitation in the event of a fault: fast opening of the contacts prevents the loads from being destroyed in the event of a short-circuit.

#### Electrical technical data

Rated service breaking capacity (Ics)	75 % of the ultimate breaking capacity (Icu)
Power loss	see module 92517
Magnetic tripping (Ii)	8.5 In (± 20 %) (compatible with curve C)
Impulse voltage (Uimp)	6 kV
Rated insulation level (Ui)	500 V DC

#### Endurance (O-C)

Electrical	<ul style="list-style-type: none"> <li>■ 3,000 cycles (where L/R=2 ms)</li> <li>■ 6,000 cycles where the circuit is resistive</li> </ul>
Mechanical	20,000 cycles

#### Complementary technical data

Degree of pollution	3				
Category	A (no delay in accordance with IEC / EN 60947-2 standards)				
Weight	<table border="1"> <tr> <td>1P</td> <td>128 g / 4.51 oz</td> </tr> <tr> <td>2P</td> <td>256 g / 9.03 oz</td> </tr> </table>	1P	128 g / 4.51 oz	2P	256 g / 9.03 oz
1P	128 g / 4.51 oz				
2P	256 g / 9.03 oz				

#### Environment

Tropicalisation	Relative humidity: 95 % at 55°C / 131°F in accordance with IEC 60068-2 and GB 14048.2 standards				
Temperature	<table border="1"> <tr> <td>Operating</td> <td>-25°C to 70 °C / -13°F to 158°F</td> </tr> <tr> <td>Storage</td> <td>-40°C to 85°C / -40°F to 185°F</td> </tr> </table>	Operating	-25°C to 70 °C / -13°F to 158°F	Storage	-40°C to 85°C / -40°F to 185°F
Operating	-25°C to 70 °C / -13°F to 158°F				
Storage	-40°C to 85°C / -40°F to 185°F				

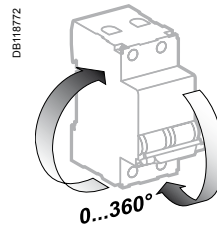
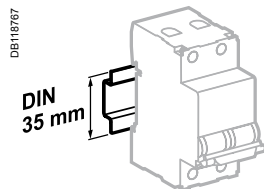

**⚠ Failure to match polarity during connection may lead to a fire hazard and/or serious injury.**

- The connection polarity must be observed (marked on the front panel).
- Use only with direct current.
- If two poles are used in series for the American network, use at least a 12 inch / 30 cm cable.

### Dimensions

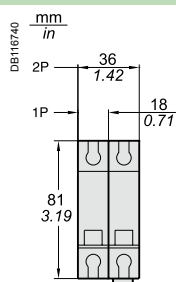

C60H-DC

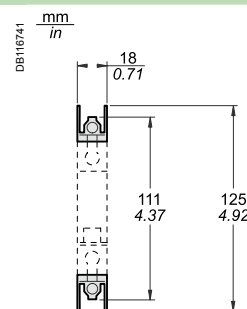
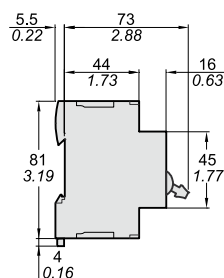

Kit for ring terminals

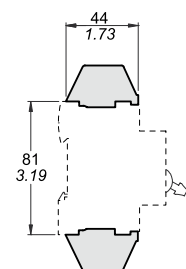

### C60 accessories

#### Connection

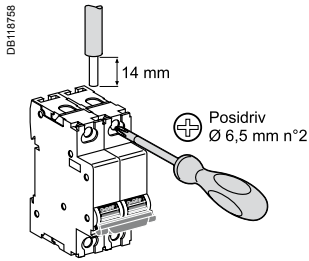

Rating	Tightening torque	Without accessory			With connection accessories			
		Copper cables UL 486A file no. #E216919			Terminal Al / Cu	Ring tongue terminal screw connection	Insulated distribution terminal	
		rigids	flexibles	with end piece			rigid cables	flexible cables
≤ 25 A	2.5 N.m / 22 lb.in	2.5 to 25 mm <sup>2</sup> #14 - #4 AWG	2.5 to 16 mm <sup>2</sup> #14 - #6 AWG	50 mm <sup>2</sup> / 1 AWG	Ø 5 mm	3 x 16 mm <sup>2</sup> 3 x 6 AWG	3 x 10 mm <sup>2</sup> 3 x 8 AWG	
> 25 A	3.5 N.m / 31 lb.in	2.5 to 35 mm <sup>2</sup> #14 - #2 AWG	2.5 to 25 mm <sup>2</sup> #14 - #4 AWG	-				

1	Insulated connector	(see module 91906)
2	Comb busbar	(see module 91906)
3	Terminal 50 mm <sup>2</sup> Al / Cu	27060
4	Ring tongue terminal screw connection	27053
5	Ring tongue terminal connections kit Ø 5 mm, (upstream/downstream)	17400
6	Insulated distribution terminal	4 pieces 19091 3 pieces 19096

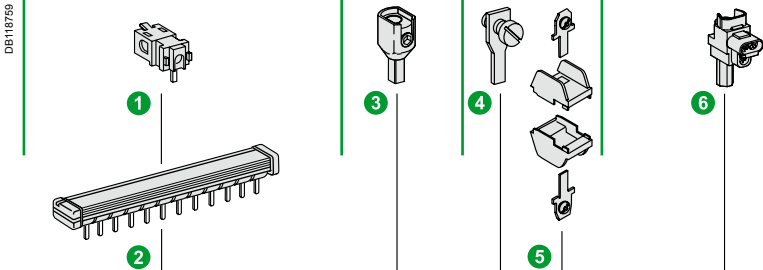

#### Assembly

7	Sealable terminal shield	26976
8	Inter-pole barrier	27001
9	Rotary handle	
	Switching sub-assembly	27046
	Disconnectable handle	27047
	Fixed handle	27048
10	Screw shield	26981
11	Padlocking accessory (to be locked in the "open" position)	26970
12	Spacer	27062
13	Dividable mounting plate	26996
14	Marker strip	(see module 91900)

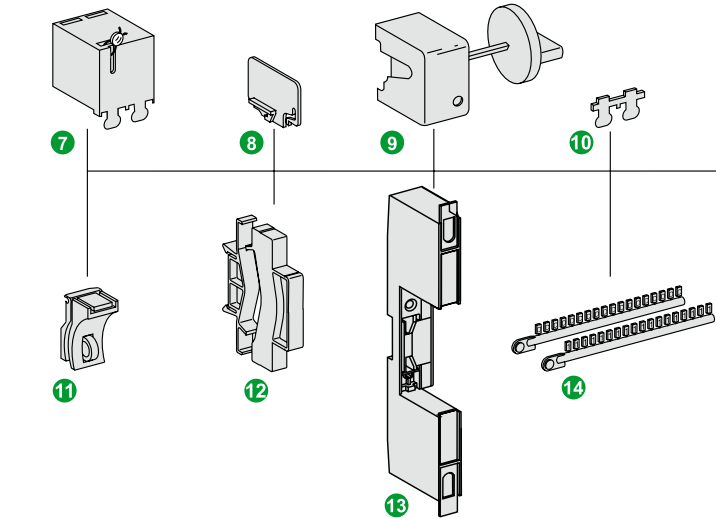

### C60 auxiliaries (see modules 90081 - 91103)

#### Indication

15	SD fault indicating switch
16	OF open/closed contact

#### Tripping

17	MN undervoltage release
18	MX + OF shunt release

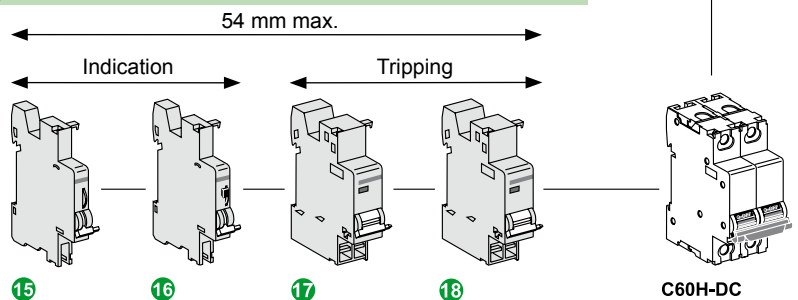

**!** The electrical auxiliaries must be installed to the left of the circuit breaker and within a width of 54 mm.  
**!** If the auxiliary SD contacts are associated with the tripping auxiliaries (MN, MX, etc.), they must be installed to the left of these auxiliaries.

**Poles connected in series**

Network selection			
Type	Earthed		Isolated from earth
Source	Earthed polarity (in this case negative)	Earthed central point	Isolated polarities
Protected polarities	1 (1P isolation)	2	2
Diagrams (and type of faults)			

Selection of supplementary protector and pole connection			
24 V ≤ Un ≤ 250 V	Single-pole	Two-pole	Two-pole
Upstream connection	Only if L+ polarity is earthed		
Downstream connection			
250 V < Un ≤ 500 V	Two-pole	Two-pole	Two-pole
Upstream connection			
Downstream connection			

Fault analysis (low earth connection resistance)			
<b>Fault A</b>	<ul style="list-style-type: none"> <li>Isc maximum at U</li> <li>only protected polarity concerned</li> <li>all the poles of the protected polarity must have a breaking capacity ≥ Isc max. at U</li> </ul>	<ul style="list-style-type: none"> <li>Isc maximum at U/2</li> <li>only positive polarity concerned</li> <li>all the positive polarity poles must have a breaking capacity ≥ Isc max. at U/2</li> </ul>	<ul style="list-style-type: none"> <li>not relevant</li> <li>the fault must be indicated by a permanent insulation monitor (PIM) and cleared (IEC/EN 60364)</li> </ul>
<b>Fault B</b>	<ul style="list-style-type: none"> <li>Isc maximum at U</li> <li>if one polarity (in this case positive) is protected: all the poles of this polarity must have a breaking capacity ≥ Isc max. at U</li> <li>if two polarities are protected, to ensure isolation: all the protections of the two polarities must have a breaking capacity ≥ Isc max. at U</li> </ul>	<ul style="list-style-type: none"> <li>Isc maximum at U</li> <li>the 2 polarities are concerned</li> <li>all the poles of the two polarities must have a breaking capacity ≥ Isc max. at U</li> </ul>	<ul style="list-style-type: none"> <li>Isc maximum at U</li> <li>the 2 polarities are concerned</li> <li>all the poles of the two polarities must have a breaking capacity ≥ Isc max. at U</li> </ul>
<b>Fault C</b>		<ul style="list-style-type: none"> <li>as for fault A</li> <li>all the negative polarity poles must have a breaking capacity ≥ Isc max. at U/2</li> </ul>	<ul style="list-style-type: none"> <li>as for fault A with the same requirements</li> </ul>

### Tripping curves

#### C curve as in standard IEC 60947.2

- The operating range of the magnetic release is as follows between  $7 I_n$  and  $10 I_n$ .
- The curves show the cold thermal tripping limits when poles are charged and the electromagnetic tripping limits with 2 charged poles.
- The curves are used without any derating.

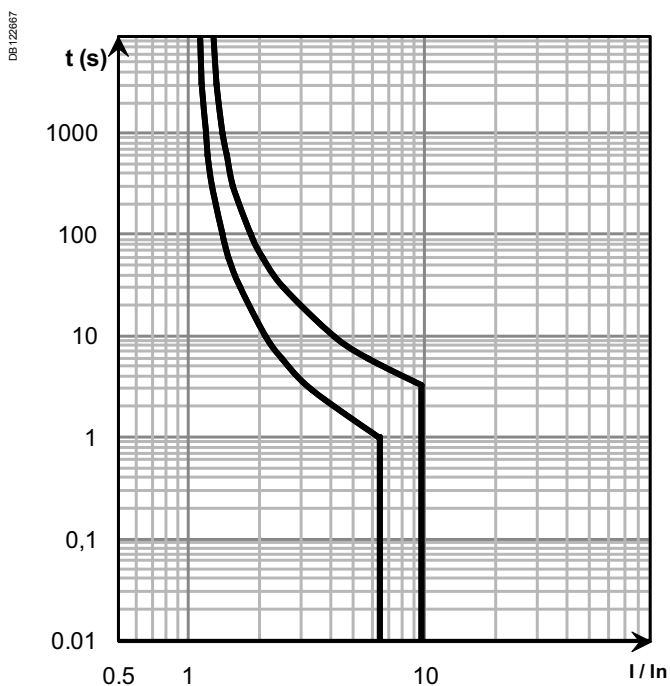

**Temperature derating (according to UL 1077/ CSA22.2/ UL489A/ UL489/ IEC 60947-2 standards)**

The maximum permissible current in a device depends on the ambient temperature in which it is placed. Ambient temperature is the temperature inside the enclosure or switchboard in which the devices have been installed.

The reference temperature is in the coloured column.

When several simultaneously operating devices are mounted side by side in a small enclosure, the temperature rise inside the enclosure causes a reduction in the current rating. A reduction coefficient of the order of 0.8 must therefore be allocated to the rating (already derated if it depends on the ambient temperature).

Temperature (°C)	-30	-25	-20	-15	-10	-5	0	5	10	15	20	25	30	35	40	45	50	55	60	65	70	
Rating (A)																						
0.5	0.63	0.62	0.61	0.60	0.59	0.58	0.56	0.55	0.54	0.53	0.51	0.5	0.49	0.47	0.46	0.44	0.43	0.41	0.39	0.38	0.36	
1	1.18	1.17	1.15	1.14	1.12	1.10	1.09	1.07	1.05	1.04	1.02	1	0.98	0.96	0.94	0.92	0.90	0.88	0.86	0.84	0.82	
1.2	1.45	1.43	1.41	1.39	1.37	1.34	1.32	1.30	1.27	1.25	1.22	1.2	1.17	1.15	1.12	1.09	1.07	1.04	1.01	0.98	0.95	
1.5	1.86	1.83	1.80	1.77	1.74	1.71	1.67	1.64	1.61	1.57	1.54	1.5	1.46	1.42	1.39	1.34	1.30	1.26	1.22	1.17	1.12	
2	2.54	2.50	2.45	2.41	2.36	2.31	2.26	2.21	2.16	2.11	2.06	2	1.94	1.88	1.82	1.76	1.70	1.63	1.56	1.48	1.41	
3	3.78	3.71	3.65	3.58	3.51	3.45	3.38	3.30	3.23	3.16	3.08	3	2.92	2.84	2.75	2.66	2.57	2.48	2.38	2.27	2.17	
4	5.08	4.99	4.90	4.81	4.71	4.62	4.52	4.42	4.32	4.22	4.11	4	3.89	3.77	3.65	3.53	3.40	3.27	3.13	2.98	2.83	
5	6.00	5.92	5.83	5.74	5.66	5.57	5.48	5.39	5.29	5.20	5.10	5	4.90	4.80	4.69	4.58	4.47	4.36	4.24	4.12	4.00	
6	7.26	7.15	7.04	6.94	6.83	6.71	6.60	6.48	6.37	6.25	6.12	6	5.87	5.74	5.61	5.47	5.33	5.19	5.04	4.89	4.73	
7	8.76	8.62	8.47	8.32	8.17	8.01	7.85	7.69	7.52	7.35	7.18	7	6.82	6.63	6.44	6.24	6.03	5.82	5.60	5.37	5.13	
8	9.64	9.50	9.36	9.22	9.08	8.93	8.78	8.63	8.48	8.32	8.16	8	7.83	7.67	7.49	7.31	7.13	6.95	6.76	6.56	6.36	
10	12.59	12.38	12.16	11.94	11.71	11.49	11.25	11.01	10.77	10.52	10.26	10	9.73	9.45	9.17	8.87	8.57	8.25	7.92	7.58	7.22	
13	15.49	15.28	15.07	14.85	14.63	14.41	14.19	13.96	13.72	13.49	13.25	13	12.75	12.49	12.23	11.97	11.69	11.41	11.13	10.83	10.53	
15	18.61	18.31	18.01	17.70	17.38	17.06	16.74	16.40	16.07	15.72	15.36	15	14.63	14.25	13.85	13.45	13.03	12.60	12.16	11.69	11.21	
16	19.43	19.14	18.85	18.55	18.25	17.95	17.64	17.32	17.00	16.68	16.34	16	15.65	15.29	14.93	14.56	14.17	13.78	13.37	12.95	12.52	
20	24.06	23.72	23.37	23.02	22.67	22.31	21.94	21.56	21.18	20.80	20.40	20	19.59	19.17	18.74	18.30	17.85	17.39	16.92	16.43	15.93	
25	30.35	29.91	29.45	28.99	28.52	28.05	27.56	27.07	26.57	26.06	25.53	25	24.46	23.90	23.33	22.74	22.14	21.53	20.89	20.24	19.56	
30	37.35	36.74	36.12	35.50	34.86	34.21	33.54	32.86	32.17	31.46	30.74	30	29.24	28.46	27.66	26.83	25.98	25.10	24.19	23.24	22.25	
32	38.45	37.91	37.36	36.80	36.24	35.66	35.08	34.48	33.88	33.27	32.64	32	31.35	30.68	30.00	29.31	28.59	27.86	27.11	26.34	25.54	
35	44.15	43.40	42.63	41.86	41.06	40.25	39.42	38.58	37.72	36.83	35.93	35	34.05	33.06	32.05	31.01	29.93	28.81	27.64	26.42	25.14	
40	48.92	48.17	47.42	46.65	45.87	45.08	44.28	43.45	42.62	41.76	40.89	40	39.09	38.16	37.20	36.22	35.21	34.17	33.10	31.99	30.84	
50	59.93	59.09	58.25	57.39	56.52	55.63	54.74	53.82	52.89	51.95	50.98	50	49.00	47.97	46.93	45.86	44.77	43.64	42.49	41.31	40.09	
60	76.16	74.83	73.48	72.11	70.71	69.28	67.82	66.33	64.81	63.25	61.64	60	58.31	56.57	54.77	52.92	50.99	48.99	46.90	44.72	42.43	
63	78.16	76.91	75.63	74.33	73.01	71.67	70.30	68.90	67.47	66.02	64.53	63	61.44	59.83	58.18	56.49	54.74	52.93	51.06	49.12	47.10	