

* = Conical form tapering downward.
 Untoleranced dimensions per GTA 13/5 DIN 1688

LID

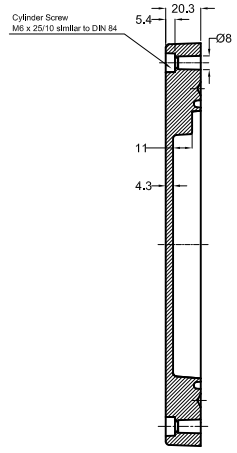

SECTION B-B

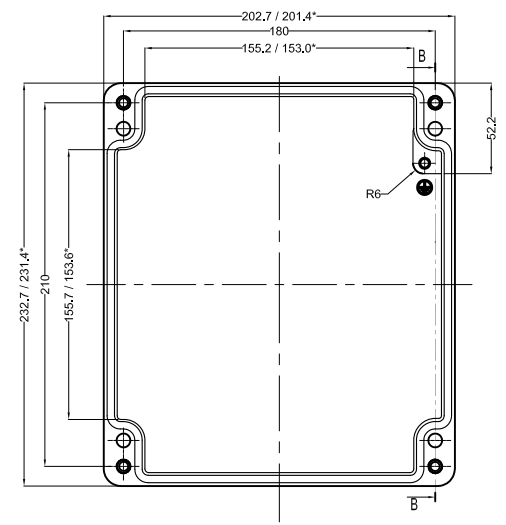
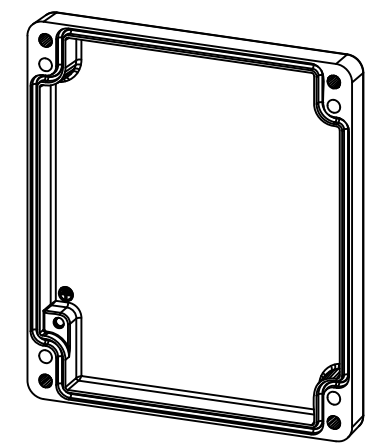

BASE

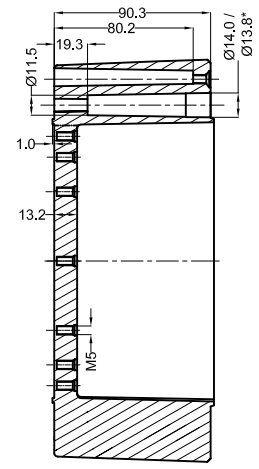
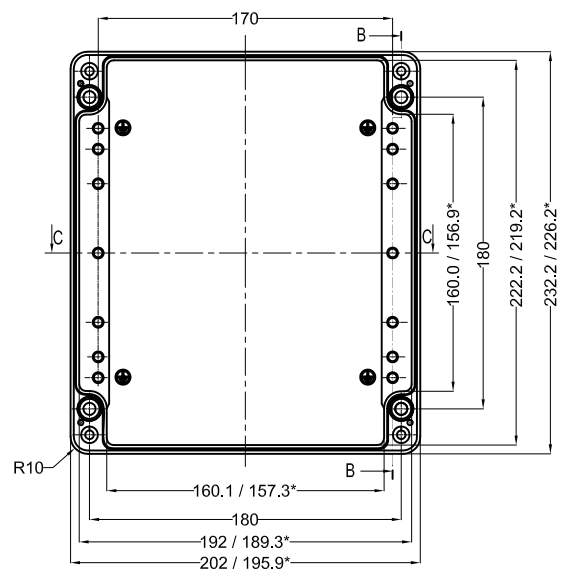

SECTION B-B

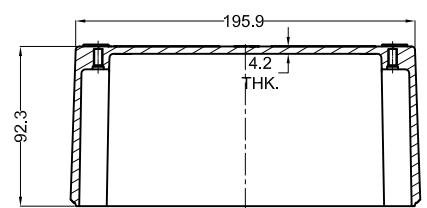
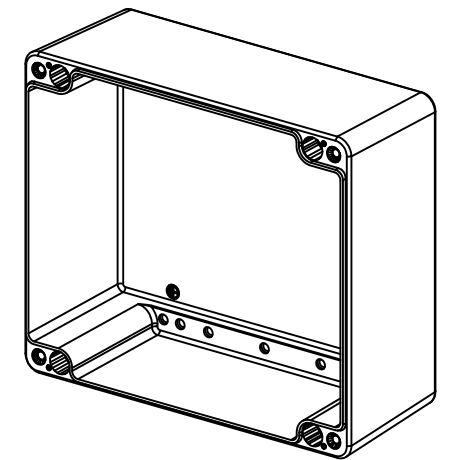

SECTION C-C



QUANTITY 1	MATERIAL :- ALs112 (Din230)	MACH.NAME -	DATE 13/06/12	SIGN MANOJ	NAME DRAWN
	WEIGHT: -	FINISH: NATURAL	DATE 13/06/12	SIGN PAVAN	NAME CHECKED
	TOLERANCE ±0.2 DIMENSIONS ±0.2 HOLES ±1.0° ANGLES	ALL DIMENSION ARE IN MM	TITLE :- JUNCTION BOX 230 x 200 x 110		
SCALE			APPROVED S. D.		