

Terminal Protection to IP20



Dims: to DIN 43880
W. 17.5mm

- ❑ ***NEW* 17.5mm DIN rail housing**
- ❑ **Switch Initiated Delay Off (Delay On Release) re-triggerable timing function**
- ❑ **7 Selectable time ranges (0.1 seconds – 100 hours)**
- ❑ **Fine adjustment of selected time range**
- ❑ **Multi-voltage input (12 – 230V AC/DC)**
- ❑ **External trigger input can be from Voltage Free Contact or Solid State**
- ❑ **Timer will still function with load connected to trigger (B1) input**
- ❑ **1 x DPDT relay output 8A**
- ❑ **Green LED indication for supply / timing status**
- ❑ **Red LED indication for relay status**
- ❑ **Conforms to IEC 61812**

Wiring Information and Product Demonstration Videos can also be found on our YouTube channel <https://www.youtube.com/user/BroyceControlLtd>



FUNCTION DIAGRAM

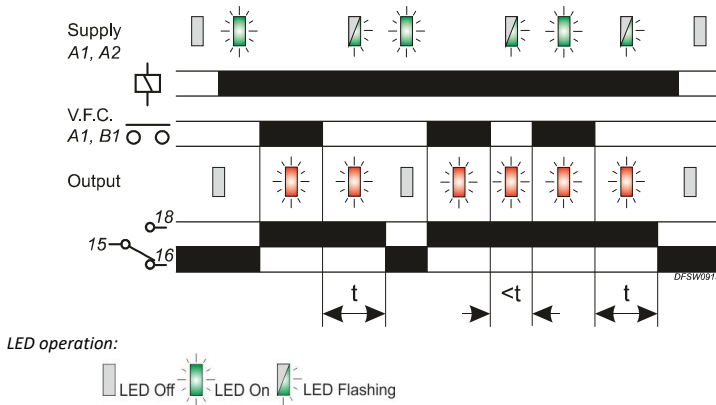

INSTALLATION AND SETTING

- BEFORE INSTALLATION, ISOLATE THE SUPPLY.
- Connect the unit as required.



Installation work must be carried out by qualified personnel.

Setting the unit.

- Set the "Range" ④ to the required position (depending on whether seconds, minutes or hours are required).
- Set the "Set %" adjustment ③ as required. The "Set %" is a % of the selected range; so for example, a 30% setting on the 1 – 10 hour range will give 3 hours.

Applying power.

- Apply power across terminals **A1** and **A2** and the green LED ① will illuminate.
- The relay will remain de-energised (contacts **15 / 18** and **25 / 28** open, **15 / 16** and **25 / 26** closed) and red LED ② extinguished.
- Close the contact across **A1** and **B1** and the relay will energise (contacts **15 / 18** and **25 / 28** closed, **15 / 16** and **25 / 26** open) and red LED illuminate.
- When the contact across **A1** and **B1** opens, the delay period "t" will begin and the green LED will flash to indicate timing is now in progress.
- After the delay period "t" has elapsed, the relay will de-energise (contacts **15 / 18** and **25 / 28** open, **15 / 16** and **25 / 26** closed) and the red LED will extinguish.
- The green LED will now remain permanently lit.
- The whole timing process is repeated by removing and re-applying power.
- If during the time period "t", the contact across **A1** and **B1** closes, timing will stop and restart over again the next time the contact opens.

Note:

¹ In accordance with IEC 61812, the green LED is permitted to extinguish during a voltage dip or momentary interruption of the power supply providing the state of the output relay does not change. The dip / interruption duration and levels are defined in the product standard.

TECHNICAL SPECIFICATION

Supply voltage U (A1, A2):	12 – 230V AC/DC
Frequency range:	48 - 63Hz (AC supplies)
Supply variation:	+/- 15%
Overvoltage category:	III (IEC 60664)
Rated impulse withstand voltage:	4kV (1.2/50µs) IEC 60664
Power consumption (max.):	12V 24V 110V 230V
	AC: 0.3VA 0.4VA 1.3VA 3.4VA
	DC: 0.26W 0.24W 0.47W 0.95W
Timing function:	Switch Initiated Delay Off
Timing ranges (7):	Seconds: Minutes: Hours:
	0.1 – 1 0.1 – 1 0.1 – 1
	1 – 10 1 – 10 1 – 10
	10 - 100
Reset time:	100mS
Accuracy:	± 1% of maximum full scale
Adjustment accuracy:	< 5% of maximum full scale
Repeat accuracy:	± 0.5% at constant conditions (IEC 61812)
Drift with temperature:	± 0.05% / °C
Drift with voltage:	± 0.2% / V
External trigger input (A1 > B1):	Volt Free Contact, Open Collector
External loading:	Yes, between B1 and A2 (i.e. LED, Relay, Lamp)
Trigger threshold:	>75% of voltage present between A1 and A2 (auto-set)
Minimum trigger time:	AC: 60mS DC: 40mS (B1 terminal unloaded)
Maximum input frequency:	10 Hz (with 50:50 duty cycle)
Maximum cable length:	10m (between Timer and external switching device)
Power on indication / Timing ¹ :	Green LED
Relay status:	Red LED
Ambient temp:	-20 to +60°C
Relative humidity:	+95%
Output (15, 16, 18/25, 26, 28):	DPDT relay
Output rating:	AC1 250V 8A (2000VA)
	AC15 250V 5A (nc), 3A (nc)
	DC1 25V 8A (200W)
Electrical life:	≥ 150,000 ops at rated load
Dielectric voltage:	2kV AC (rms) IEC 60947-1
Rated impulse withstand voltage:	4kV (1.2/50µs) IEC 60664
Housing:	Grey flame retardant UL94
Weight:	≈ 60g
Mounting option:	On to 35mm symmetric DIN rail to BS EN 60715 or direct surface mounting via 2 x M3.5 or 4BA screws using the black clips provided on the rear of the unit.
Terminal conductor size:	≤ 2 x 2.5mm ² solid or stranded
Terminal screw:	M3 (Designed for use with PZ1 "pozi-driver")
Tightening torque:	0.6Nm Max.
Approvals:	Conforms to IEC 61812.
	US LISTED IND. CONT. EQ. E111187
	CE, UKCA, C-tick and RoHS Compliant.
	EMC: Immunity: EN 61000-6-2 (EN 61000-4-3 10V/m 80MHz - 2.7GHz)
	Emissions: EN 61000-6-4

CONNECTION DIAGRAM

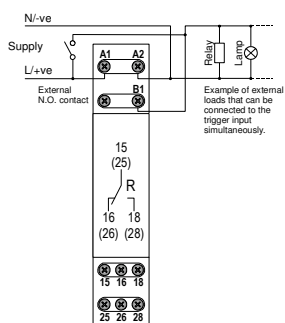

SETTING DETAILS

1. Power supply status / Timing (Green) LED
2. Relay output status (Red) LED
3. "Set %" adjustment
4. Time delay "Range" selector

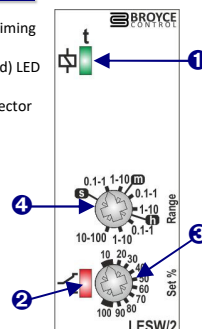

DIMENSIONS

