

Sensor mounting, Series CB1

- for series ST6, SM6

- to mount on cylinder MNI, ICM



Weight

See table below

Technical data

Part No.	Cylinders Ø	for series	Weight
	min.		
1827020296	10 mm	ST6, SM6	0,009 kg
1827020297	12 mm	ST6, SM6	0,01 kg
1827020298	16 mm	ST6, SM6	0,014 kg
1827020299	20 mm	ST6, SM6	0,014 kg
1827020300	25 mm	ST6, SM6	0,015 kg

Technical information

Material

Aluminum

Dimensions

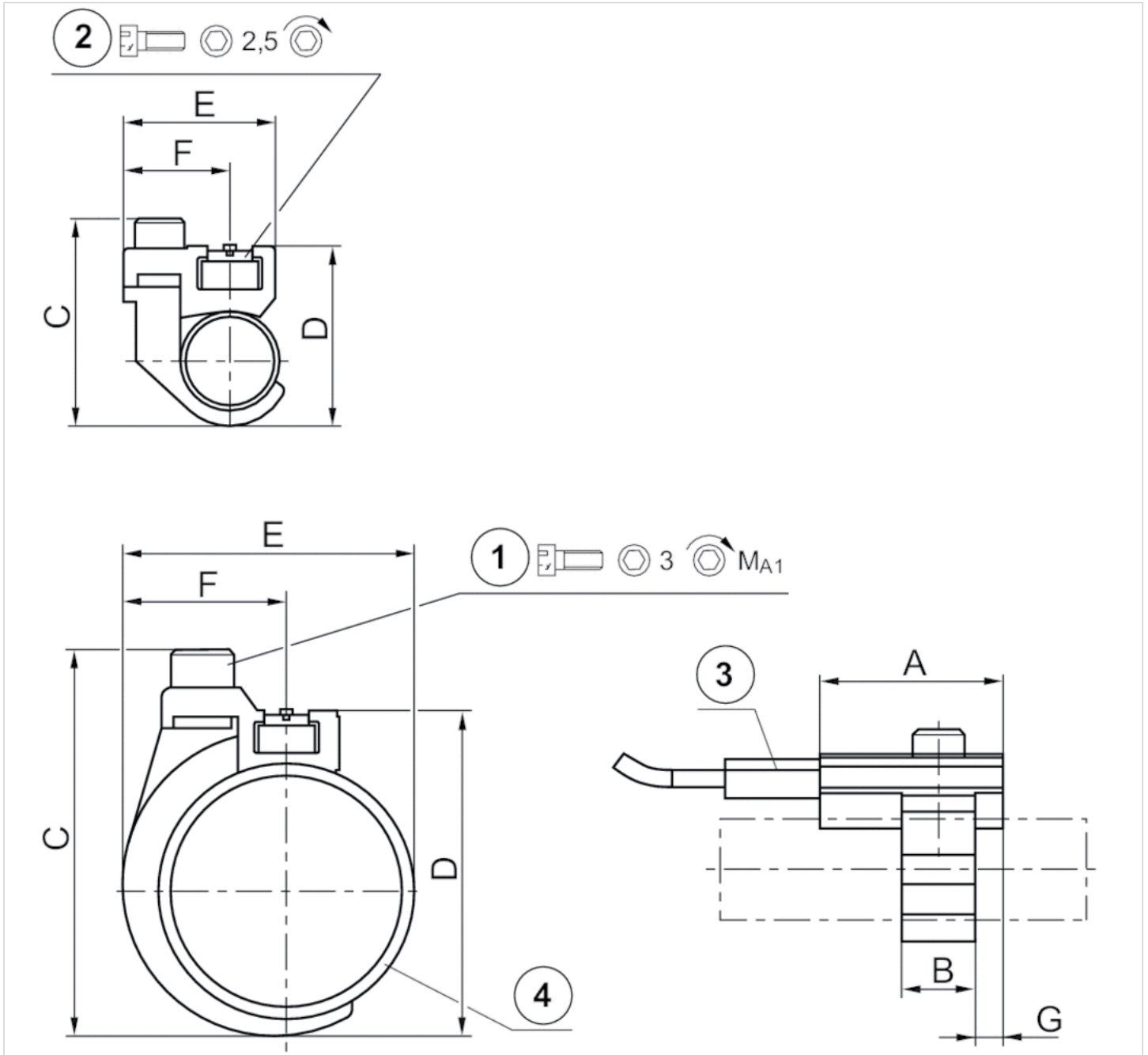

1) Mounting screw 2) Mounting screw for sensor 3) Sensor 4) Cylinder pipe

Dimensions

Part No.	A	B	C	D	E	F	G	1)	MA1 [Nm]
1827020296	20	8	24	19	17.5	11.8	3	M3x8	1 +0,2
1827020297	20	8	26	22	19	11.8	3	M3x8	1 +0,2
1827020298	20	12	34	30	23	13.8	4	M4x10	2 +0,3
1827020299	20	12	38	32	26	13.8	4	M4x10	2 +0,3
1827020300	20	12	43	37	31	13.8	4	M4x10	2 +0,3