

THIS DRAWING IS UNPUBLISHED. RELEASED FOR PUBLICATION
 © COPYRIGHT BY TYCO ELECTRONICS CORPORATION. ALL RIGHTS RESERVED.

LOC	DIST	REVISIONS					
G	14	P	LTR	DESCRIPTION	DATE	DWN	APVD
		G1		REV PER ECR 09-023200	27OCT09	JR	TM

AMP WIRE RANGE	Listed FILE E13288	LR7189 Certified
22-16 AWG SOLID OR STRANDED	22-16 AWG SOLID OR STRANDED	22-16 AWG SOLID OR STRANDED

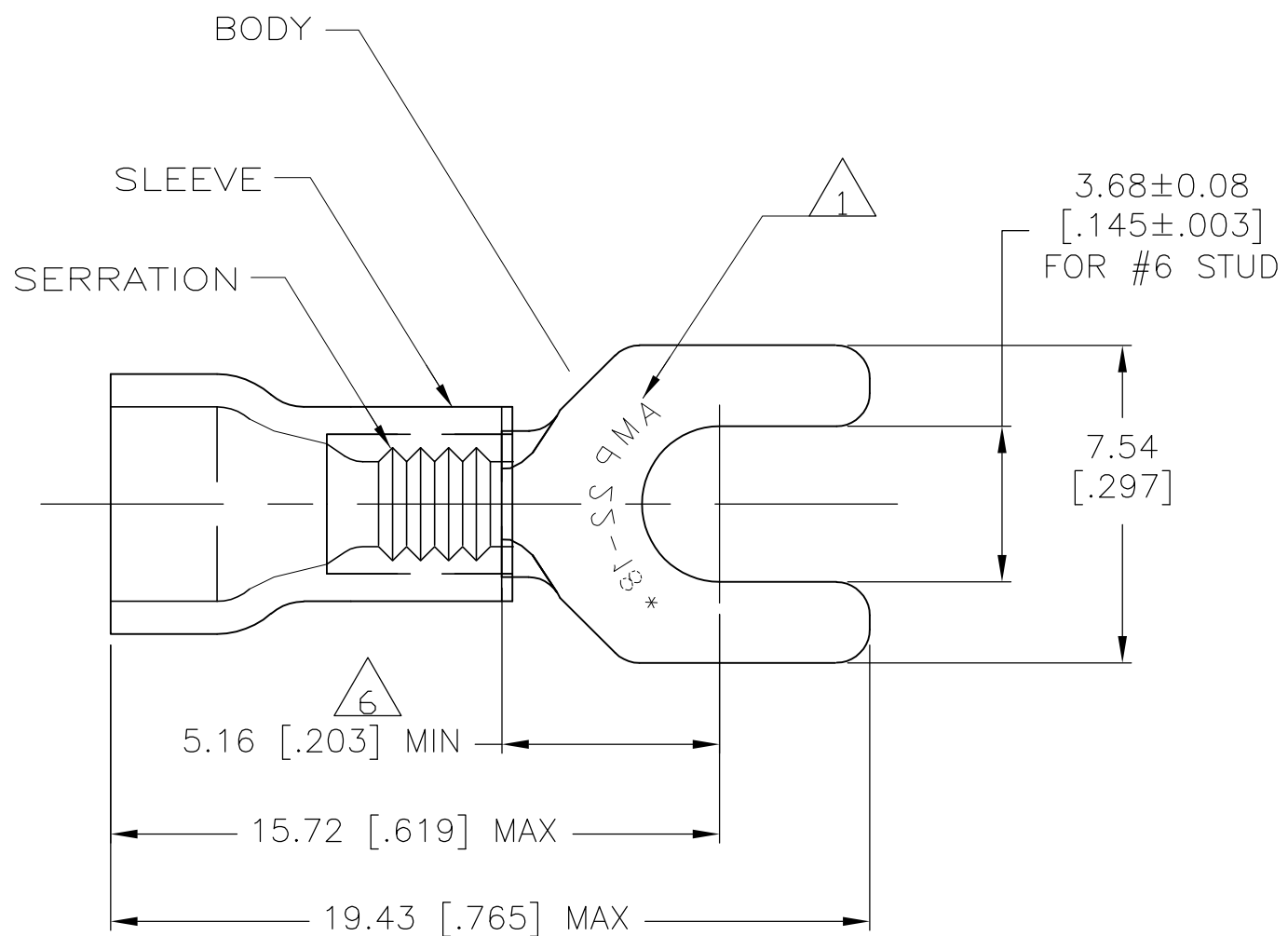

- ① STAMP AMP 22-18* APPROX AS SHOWN
22-16 TERMINALS ARE STAMPED 22-18 IN ACCORDANCE WITH MILITARY SPEC MIL-T-7928
COMMERCIAL WIRE RANGE IS 22-16
- 2. WIRE INSUL DIA, 2.67 TO 3.56 [.105 TO .140]
- 3. TONGUE MATL THK, 0.79 ± 0.05 [.031 ± .002]
- ④ SUPERSEDED BY 8-320665-5
- ⑤ MATERIAL: BODY - CU PER ASTM B152
SLEEVE - PVC, COLOR - RED
- ⑥ APPLIES FROM THE METAL EDGE OF BARREL TO THE CENTER OF THE STUD.

④	50	LOOSE PIECE, BAG	8-320665-5
	5	LOOSE PIECE, BLS	8-320665-4
	100	LOOSE PIECE, BOX	8-320665-1
	5000	ON TAPE, REEL	2-320665-1
	1000	LOOSE PIECE	320665
	QTY	PACKAGE TYPE	PART NO

AMP INCORPORATED CUSTOMER SERVICE SYSTEMS		MAX RECOMMENDED OPERATING TEMPERATURE: 105°C	THIS DRAWING IS A CONTROLLED DOCUMENT.		DWN G VINSON 28NOV94	Tyco Electronics Corporation Harrisburg, Pa 17105-3608			
FOR ADDITIONAL PRODUCT INFORMATION OR COPIES OF DRAWINGS AND TECHNICAL DOCUMENTS	PRODUCT INFORMATION CENTER 1-800-522-6752	VOLTAGE RATING: 600V MAX (1000V FIXTURE OR SIGN)	DIMENSIONS: mm [INCHES]	TOLERANCES UNLESS OTHERWISE SPECIFIED:	CHK M ELLIS 28NOV94	NAME G NGO			
FOR APPLICATION TOOLING INFORMATION	TOOLING ASSISTANCE CENTER 1-800-722-1111	CIRCULAR MIL AREA: 0.26-1.65mm² [509-3260] SOLID OR STRANDED		0 PLC ± - 1 PLC ± - 2 PLC ± 0.20 [.008] 3 PLC ± - 4 PLC ± - ANGLES ± -	APVD G NGO 28NOV94	PRODUCT SPEC UL 486A			
FOR ORDER ENTRY	1-800-526-5142	THIS DRAWING IS A CONTROLLED DOCUMENT FOR AMP INCORPORATED. IT IS SUBJECT TO CHANGE AND THE CONTROLLING ENGINEERING ORGANIZATION SHOULD BE CONTACTED FOR THE LATEST REVISION.	MATERIAL - ⑤ -	FINISH -	APPLICATION SPEC -	SIZE A3	CAGE CODE 00779	DRAWING NO G-320665	RESTRICTED TO -
CUSTOMER DRAWING					WEIGHT -	SCALE 6:1	SHEET 1 OF 1	REV G1	