

För icke direkt toleranssatta mått gäller toleransklass  
General tolerances if not otherwise stated

NOM DIM MM		TOL CLASS		
From	To	A	B	C
(1)	6	±0.05	±0.1	±0.2
(6)	30	±0.1	±0.2	±0.5
(30)	100	±0.15	±0.3	±0.8
(100)	300	±0.2	±0.5	±1.2
(300)	1000	±0.3	±0.8	±2

Hål / Holes H13

Skarpa kanter brutna där ej annat anges.  
No sharp edges unless otherwise specified.

Övriga generella toleranser enligt ritning 4100-4644.  
Additional general tolerances in accordance with drawing 4100-4644.

MÄRKT ENLIGT RITNING 4101-0261 C  
MARKED IN ACCORDANCE WITH DRAWING 4101-0261 C

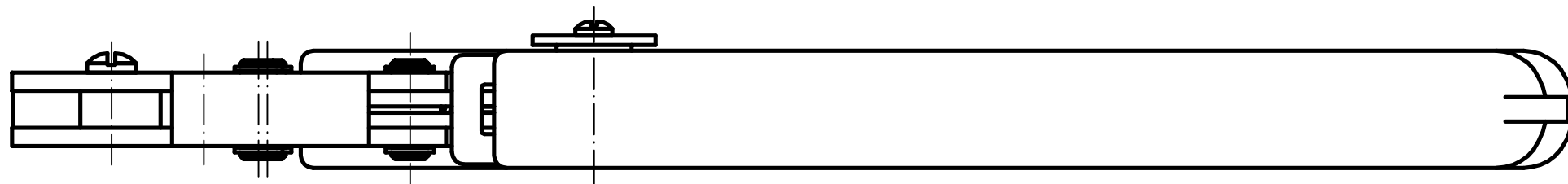

Rev	Change order	Change: A = Added W = Was D = Deleted	Date	Sign
2	1014994000	4101-0264 ÄNDRAD/CHANGED	021017	SE
3	1016252000	4101-0261C ÄNDRAD/CHANGED	030508	SE

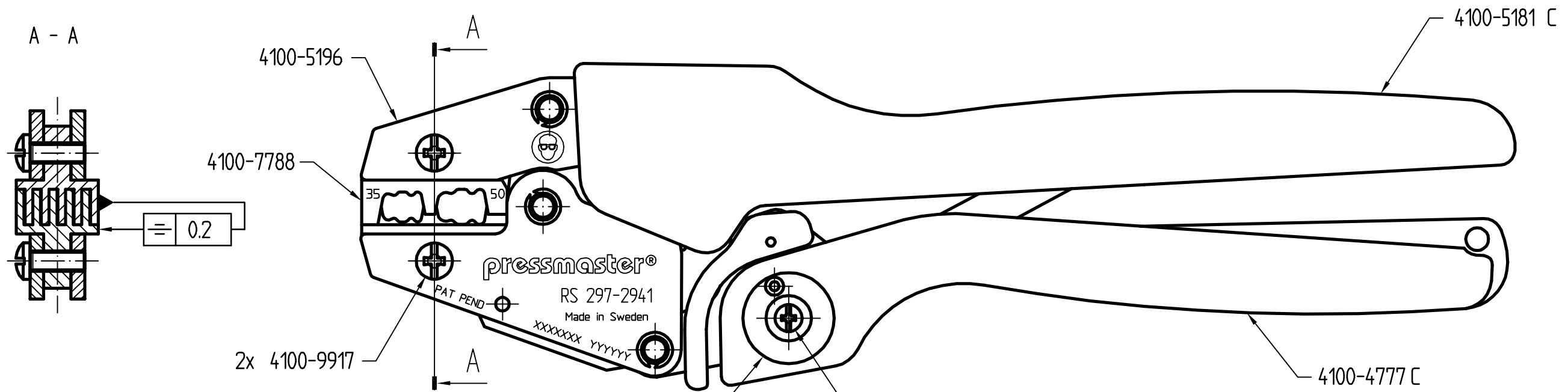

FÖRSPÄNNING / PRELOAD: 120 ± 30 N

Tolkmått / Gauge dimensions (mm)		
URTAG	Gåtolk	Stopptolk
NEST	GO	NO GO
35	Ø5.34	Ø5.54
50	Ø6.60	Ø6.80

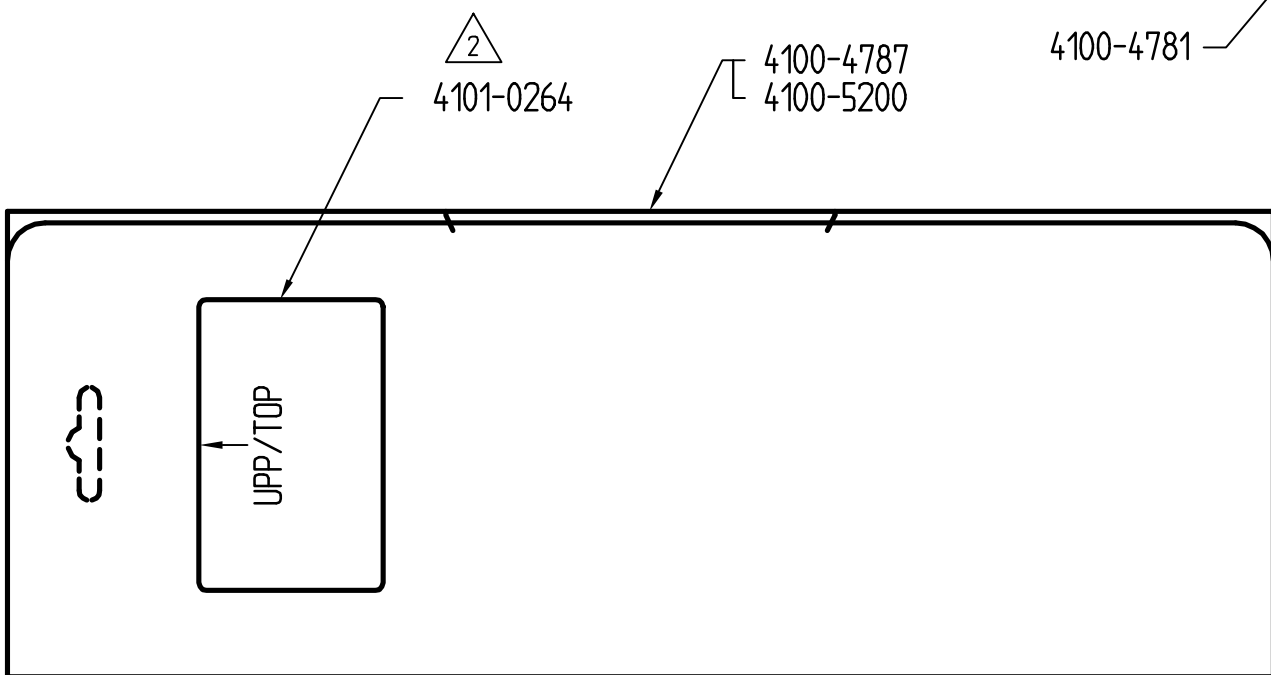

Denna ritning är Pressmaster AB:s egendom. Skyddad av gällande lag.  
This drawing is the property of Pressmaster AB. Protected in accordance with prevailing law.

Material		Behandling/Treatment			Status	
Konstr./Design		Ritad/Drawn	Datum/Date	Skala/Scale	Kontr./Checked	Godk./Approved
CF		LJ	980416	1:1		PreLutc.
<b>pressmaster®</b> Benämning/Denomination <b>KRIMPTÅNG 297-2941</b> <b>CRIMPING TOOL</b>				Vikt/Weight, gram		Art grp
				Ritn nr/Drawing no		REV
				43002431		003