



4-pole contactor, 45A/AC-1, DC operated



Powering Business Worldwide™

Part no. DILMP45-10(RDC24)

Article no. 109840

Program

Product range			Contactors
Application			Contactors for 4 pole electric consumers
Subrange			Contactors up to 200 A, 4 pole
Connection technique			Screw terminals
Pole			4 pole
Rated operational current			
AC-1			
Conventional free air thermal current, 3 pole, 50 - 60 Hz			
at 40 °C	$I_{th}=I_e$	A	45
at 50 °C	$I_{th}=I_e$	A	41
at 60 °C	$I_{th}=I_e$	A	39
Contact sequence			
For use with			DILM32-XHI(C)... DILA-XHI(V)(C)...
Voltage AC/DC			DC operation
Instructions Contacts to EN 50012. integrated suppressor circuit in actuating electronics			

Approbationen

Product Standards
UL File No.
UL CCN
CSA File No.
CSA Class No.
NA Certification
Specially designed for NA

IEC/EN 60947-4-1; UL 508; CSA-C22.2 No. 14-05; CE marking
E29096
NLDX
012528
2411-03, 3211-04
UL listed, CSA certified
No

General

Standards			IEC/EN 60947, VDE 0660, UL, CSA
Lifespan, mechanical			
AC operated	Operations	$x 10^6$	10
DC operated	Operations	$x 10^6$	10
Operating frequency, mechanical			
AC operated	Operations/h		5000
DC operated	Operations/h		5000
Climatic proofing			Damp heat, constant to IEC 60068-2-3 Damp heat, cyclic to IEC 60068-2-30
Ambient temperature		°C	
Open		°C	- 25 - 60
Enclosed		°C	- 25 - 40
Storage		°C	- 40 - 80
Mounting position, AC- and DC operated			
Mechanical shock resistance (IEC/EN 60068-2-27)			

Half-sinusoidal shock, 10 ms			
Main contacts			
N/O contact		g	10
Auxiliary contacts			
N/O contact		g	7
N/C contact		g	5
Protection type			IP00
with accessories			IP20
Protection against direct contact when actuated from front (EN 90274)			Finger- and back-of-hand proof
Terminal capacity main cable			
Solid		mm ²	1 x (0.75 - 16) 2 x (0.75 - 10)
Flexible with ferrule		mm ²	1 x (0.75 - 16) 2 x (0.75 - 10)
Stranded		mm ²	1 x 16
Solid or stranded		AWG	18 - 6
Terminal capacity control circuit cables			
Solid		mm ²	1 x (0.75 - 4) 2 x (0.75 - 2.5)
Flexible with ferrule		mm ²	1 x (0.75 - 2.5) 2 x (0.75 - 2.5)
Solid or stranded		AWG	18 - 14
Main cable connection screw/bolt			M5
Tightening torque		Nm	3
Control circuit cable connection screw/bolt			M3.5
Tightening torque		Nm	1.2
Tool			
Main cable			
Pozidriv screwdriver		Size	2
Standard screwdriver		mm	0.8 x 5.5 1 x 6
Control circuit cables			
Pozidriv screwdriver		Size	2
Standard screwdriver		mm	0.8 x 5.5 1 x 6

Main conducting paths

Rated impulse withstand voltage	U_{imp}	V AC	8000
Overvoltage category/pollution degree			III/3
Rated insulation voltage	U_i	V AC	690
Rated operational voltage	U_e	V AC	690
Safe isolation to VDE 0106 Part 101 and Part 101/A1			
between coil and contacts		V AC	440
between the contacts		V AC	440
Making capacity (p.f. to IEC/EN 60947)			
	Up to 690 V	A	350
Breaking capacity			
220/230 V		A	250
380/400 V		A	250
500 V		A	250
660/690 V		A	144
Short-circuit rating			
Short-circuit protection maximum fuse			
Type "2" coordination			
400 V	gG/gL 500 V	A	35

690 V	gG/gL 690 V	A	35
Type "1" coordination			
400 V	gG/gL 500 V	A	100
690 V	gG/gL 690 V	A	50

AC

AC-1 duty			
Rated operational current			
Conventional free air thermal current, 3 pole, 50 - 60 Hz			
Open			
at 40 °C	$I_{th}=I_e$	A	45
at 50 °C	$I_{th}=I_e$	A	41
at 60 °C	$I_{th}=I_e$	A	39
enclosed	I_{th}	A	36
Conventional free air thermal current, 1 pole			
open	I_{th}	A	117
enclosed	I_{th}	A	105
Motor rating	P	kWh	
Motor rating AC-1 230 V		kW	16
Motor rating AC-1 240 V		kW	18
Motor rating AC-1 380/400 V		kW	28
Motor rating AC-1 415 V		kW	31
Motor rating AC-1 440 V		kW	33
Motor rating AC-1 500 V		kW	37
Motor rating AC-1 690 V		kW	49
AC-3 duty			
Rated operational current AC-3 open, 50 - 60 Hz, 3 pole			
220/230 V	I_e	A	25
240 V	I_e	A	25
380/400 V	I_e	A	25
415 V	I_e	A	25
440V	I_e	A	25
500 V	I_e	A	25
660/690 V	I_e	A	15
Motor rating	P	kWh	
220/230 V	P	kW	7.5
240V	P	kW	8.5
380/400 V	P	kW	11
415 V	P	kW	14.5
440 V	P	kW	15.5
500 V	P	kW	17.5
660/690 V	P	kW	14

DC

Rated operational current, open			
DC-1 operation			
60 V	I_e	A	45
110 V	I_e	A	45
220 V	I_e	A	45
440 V	I_e	A	6
DC-3 operation			
60 V	I_e	A	45
110 V	I_e	A	45
220 V	I_e	A	45

440 V	I_e	A	4
DC-5 operation			
60 V	I_e	A	45
110 V	I_e	A	32
220 V	I_e	A	22
440 V	I_e	A	4

Current heat loss (3 pole)

Current heat loss at I_{th}		W	12
Impedance per pole		m Ω	1.5

Magnet systems

Voltage tolerance		$x U_c$	
AC operated 50 Hz	Pick-up	$x U_c$	0.8 - 1.1
AC operated 50/60 Hz		$x U_c$	0.85 - 1.1
Drop-out voltage AC operated	Drop-out	$x U_c$	0.4 - 0.6
DC operated	Pick-up	$x U_c$	0.7 - 1.2
DC operated	Drop-out	$x U_c$	0.2 - 0.6
Power consumption of the coil in a cold state and $1.0 x U_c$			
AC operated 50/60 Hz	Pick-up	VA	50
AC operated 50/60 Hz	Pick-up	W	40
AC operated 50/60 Hz	Sealing	VA	8
AC operated 50/60 Hz	Sealing	W	2.4
DC operated	Pick-up	W	12
DC operated	Sealing	W	0,5
Duty factor		% DF	100
Switching times at 100 % U_c (approximate values)			
Main contacts			
AC operated			
Closing delay		ms	16 - 22
Opening delay		ms	8 - 14
DC operated		ms	
Closing delay		ms	47
Opening delay		ms	30
Arcing time		ms	10
Permissible residual current with actuation of A1 - A2 by the electronics (with 0 signal).		mA	≤ 1

Notes

At least double-pulse bridge rectifier

Technical data according to ETIM 4.0

Number of main contacts as N/Os			4
Rated operation current I_e at AC-1, 400 V			45
Connection type main circuit			Screw connection
Rated control voltage U_s at AC 60HZ		V	0
Number of auxiliary contacts as N/Os			1
Rated control voltage U_s at AC 50HZ		V	0
Number of auxiliary contacts as N/Cs			0
Suitable for rail-mounting			No
Rated control voltage U_s at DC		V	27
Voltage type for actuation			DC
Rated operation current I_e at AC-3, 400 V		A	25
Number of N/Cs as main contact			0
Motor rating at AC-3, 400 V		kWh	11

Characteristics

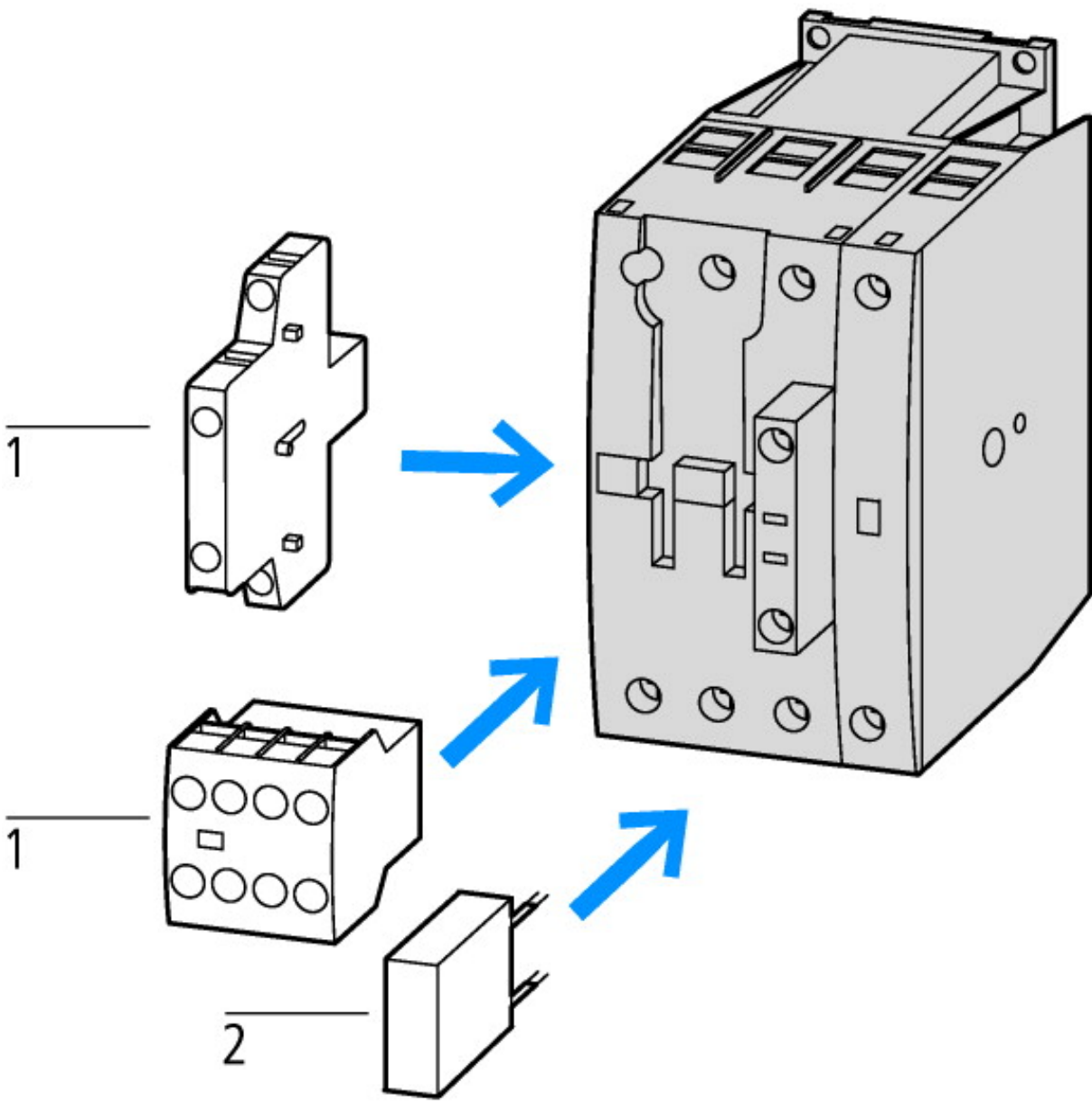

1: Auxiliary contact module
2: Suppressor

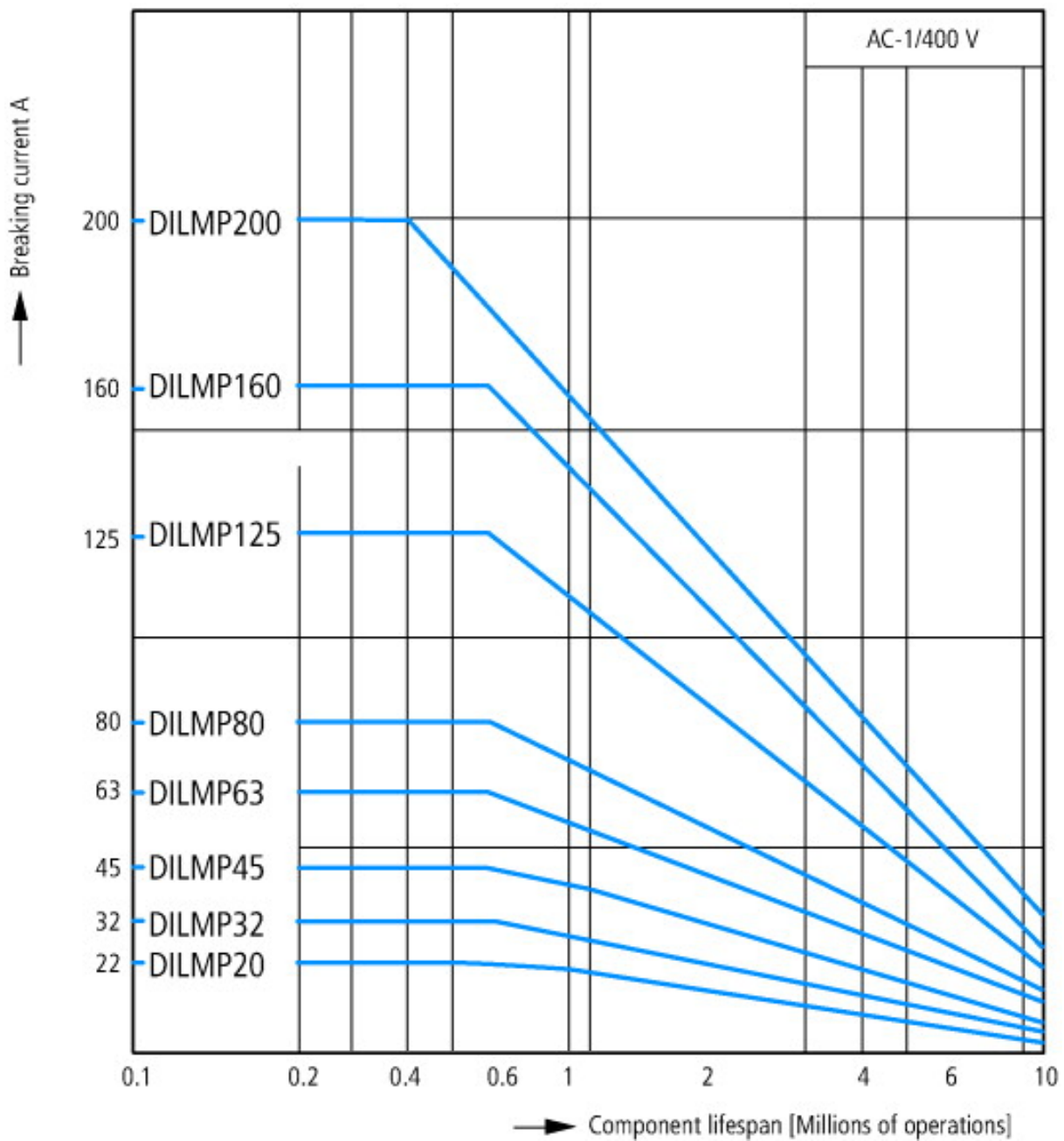

Operating characteristics
 Non inductive and slightly inductive loads
 Electrical characteristics
 Switch on: 1 × rated operational current
 Switch off: 1 × rated operational current
 Utilization category
 100 % AC-1
 Typical examples of application
 Electric heat

CAD-Data

Product standards CAD data:

<http://eaton-moeller.partcommunity.com/PARTcommunity/Portal/eaton-moeller>

Dimensions

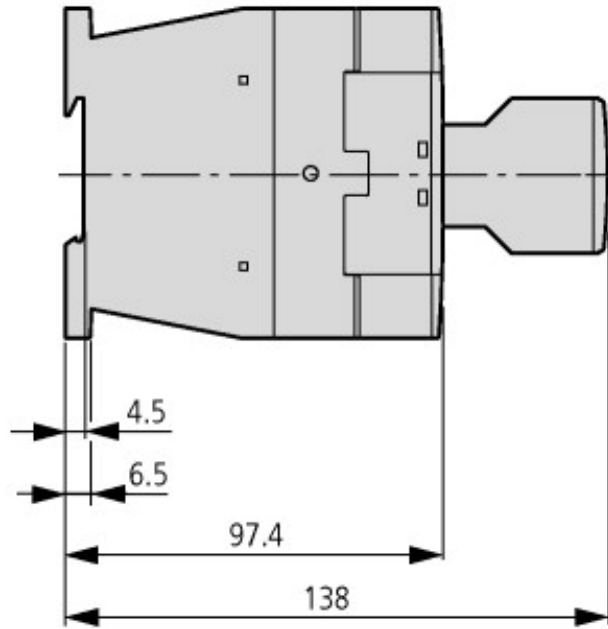
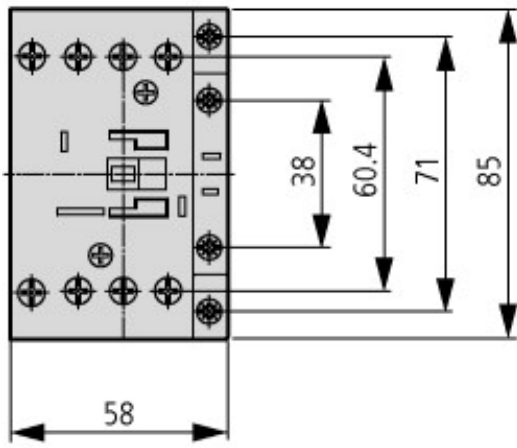

Contacteur with auxiliary contact module

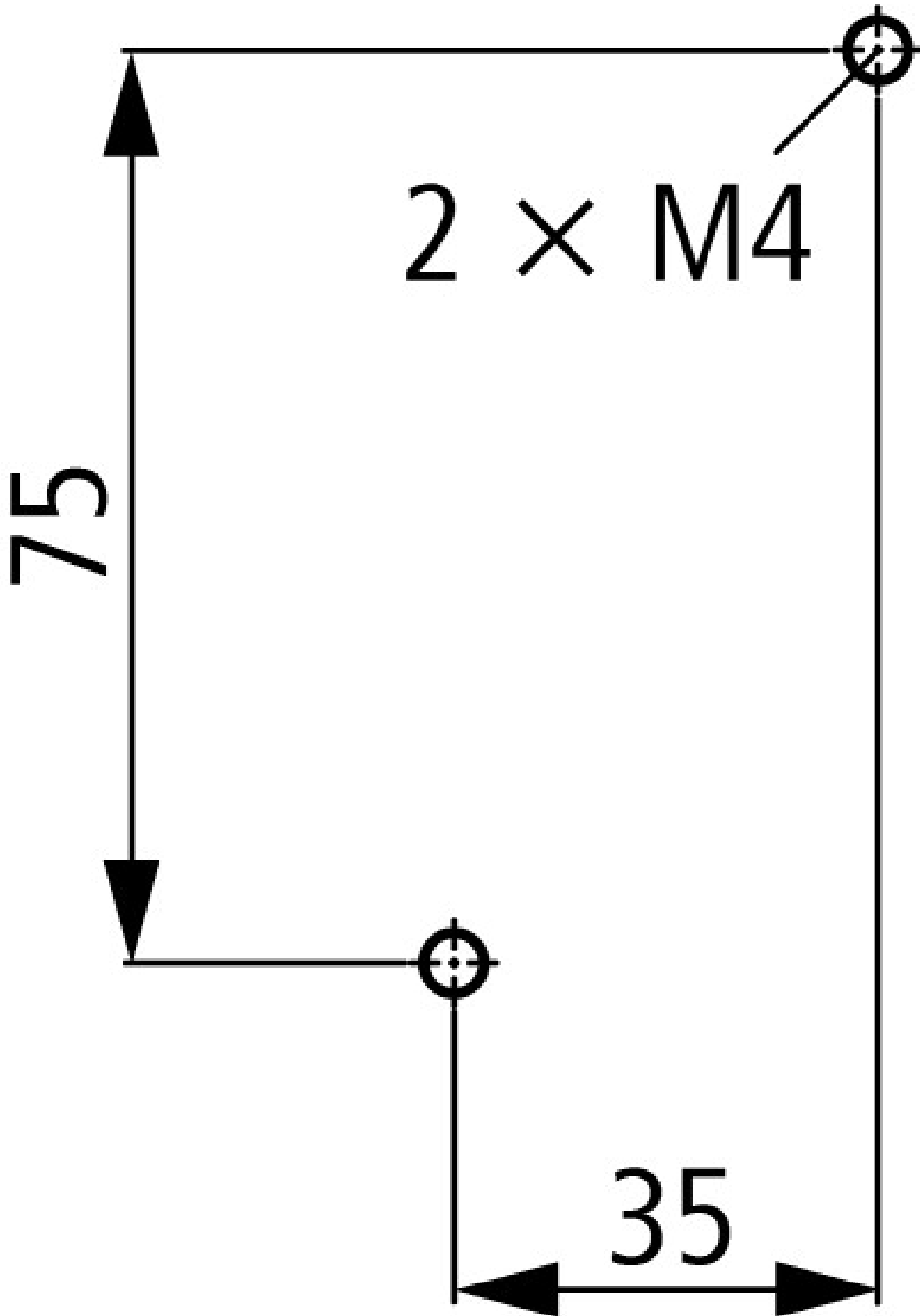

distance at side to earthed parts: 6 mm

DILMP32
DILMP45

Additional product information (links)

IL03407049Z (AWA2100-2356) 4-pole Contactor	ftp://ftp.moeller.net/DOCUMENTATION/AWA_INSTRUCTIONS/IL03407049Z2010_10.pdf
Installation Instructions	http://www.moeller.net/en/support/instructions_awa.jsp
Documentation	http://www.moeller.net/en/support/index.jsp
Motor starters and "Special Purpose Ratings" for the North American market	http://www.moeller.net/binary/ver_techpapers/ver953en.pdf
Busbar Component Adapters for modern Industrial control panels	http://www.moeller.net/binary/ver_techpapers/ver960en.pdf

The Interaction of Contactors with PLCs	http://www.moeller.net/binary/ver_techpapers/ver957en.pdf
Standard Compliant and Functionally Safe Engineering Design with Mechanical Auxiliary Contacts	http://www.moeller.net/binary/ver_techpapers/ver956en.pdf
Switchgear for Luminaires	http://www.moeller.net/binary/ver_techpapers/ver955en.pdf
Effect of the Cabel Capacitance of Long Control Cables on the Actuation of Contactors	http://www.moeller.net/binary/ver_techpapers/ver949en.pdf
X-Start - Modern Switching Installations Efficiently Fitted and Wired Securely	http://www.moeller.net/binary/ver_techpapers/ver938en.pdf
Mirror Contacts for Highly-Reliable Information Relating to Safety-Related Control Functions	http://www.moeller.net/binary/ver_techpapers/ver944en.pdf
X-Start - New Generation:100 years of Moeler contactors - Continous Progress-	http://www.moeller.net/binary/ver_techpapers/ver937en.pdf
Switchgear of Power Factor Correction Systems	http://www.moeller.net/binary/ver_techpapers/ver934en.pdf