

# PSM-ME-RS232/RS485-P



Interface converter RS-232 for RS-485 2/4-wire or RS-422

Data sheet  
100274\_en\_c06

© PHOENIX CONTACT 2020-11-25

## 1 Description

The interface converter **PSM-ME-RS232/RS485-P** converts RS-232 interface signals bidirectionally to the RS-485 2/4-wire and RS-422 standard.

The interface converter is snapped onto standard EN DIN rails in the switch cabinet and supplied with 24 V DC or AC.

You can use the device in all common bus systems with UART/NRZ data format and character length of 10/11 bits.

The RS-232 connection is established via D-SUB 9, the RS-422/RS-485 field connection is established using COMBICON plug-in screw terminal blocks.

### Features

- RS-422 4-wire for point-to-point operation
- RS-485 2-wire operation, half duplex
- RS-485 4-wire operation, full duplex
- Automatic transmit/receive changeover
- Transmission speed 1.2 kbps... 115.2 kbps
- Integrated data indicator for dynamic indication of transmit and receive data
- High-quality 3-way isolation between power supply, V.24 (RS-232), and RS-422/485 for reliable decoupling of the potentials with 1.5 kV
- Integrated surge protection with transient discharge to the DIN rail
- Shipbuilding approval in accordance with DNV GL and ABS



### **WARNING: Explosion hazard when used in potentially explosive areas**

The device is a category 3 item of electrical equipment. Follow the instructions provided here during installation and observe the safety notes.



Make sure you always use the latest documentation.

It can be downloaded at: [phoenixcontact.net/product/2744416](https://phoenixcontact.net/product/2744416)

---

<b>2</b>	<b>Table of contents</b>	
1	Description .....	1
2	Table of contents .....	2
3	Ordering data .....	3
4	Technical data .....	4
5	Safety notes.....	8
	5.1 Installation notes .....	8
	5.2 Installation in Zone 2.....	8
	5.3 UL notes.....	9
6	Transport and unpacking .....	9
7	Application examples .....	10
	7.1 RS-232 // RS-485 .....	10
	7.2 RS-232 // RS-422 .....	10
8	Product description.....	11
9	RS-232 interface.....	12
	9.1 Configuration.....	13
	9.2 DTE/DCE adjustment .....	13
	9.3 RTS/CTS support (DIP 5) .....	13
	9.4 RTS/CTS inversion (DIP 6).....	13
10	Operation as RS-485 2-wire interface.....	14
11	Operation as RS-485 4-wire interface.....	15
12	Operation as RS-422 interface .....	16
13	Termination resistor for RS-485/422 interface .....	17
14	Installation .....	18
	14.1 Mounting .....	18
	14.2 Removal.....	18
	14.3 Connecting the supply voltage .....	18
15	Disposal.....	19

### 3 Ordering data

Description	Type	Order No.	Pcs./Pkt.
Interface converter, for converting RS-232 (V.24) to RS-422 (V.11) and RS-485, with electrical isolation, 2 channels, rail-mountable	PSM-ME-RS232/RS485-P	2744416	1
<b>Accessories</b>			
RS-232 cable, 9-pos. D-SUB socket on 9-pos. D-SUB socket, 9-wire, 1:1	PSM-KA9SUB9/BB/2METER	2799474	1
Shield connection clamp for printed circuit terminal block	ME-SAS	2853899	10
Actuation tool, for ST terminal blocks, also suitable for use as a bladed screwdriver, size: 0.6 x 3.5 x 100 mm, 2-component grip, with non-slip grip	SZF 1-0,6X3,5	1204517	10
Active termination resistor for PROFIBUS and RS-485 bus systems, redundant power supply, routing of the supply voltage via DIN rail connector, electrical isolation, switchable termination, integrated programming interface	PSI-TERMINATOR-PB-TBUS	2702636	1
D-SUB plug, 9-pos. female connector, one cable entry < 35°, universal type for all systems, pin assignment: 1, 2, 3, 4, 5, 6, 7, 8, 9 to screw connection terminal block	SUBCON 9/F-SH	2761499	1

## 4 Technical data

<b>Supply</b>	
Supply voltage range	18 V AC/DC ... 30 V AC/DC (via pluggable COMBICON screw terminal block)
Nominal supply voltage	24 V AC/DC
Typical current consumption	85 mA (24 V DC)
Max. current consumption	100 mA
Electrical isolation	VCC // V.24 (RS-232) // RS-485
Test voltage data interface/power supply	1.5 kV AC
Torque	0.56 Nm ... 0.79 Nm
Conductor cross section	
	flexible 0.20 mm <sup>2</sup> ... 2.50 mm <sup>2</sup>
	rigid 0.20 mm <sup>2</sup> ... 2.50 mm <sup>2</sup>
	AWG flexible 24 AWG ... 12 AWG
	AWG 24 AWG ... 12 AWG
<b>V.24 (RS-232) interface in acc. with ITU-T V.28, EIA/TIA-232, DIN 66259-1</b>	
Transmission channels	2 (1/1), RxD, TxD, full duplex
Connection method	D-SUB 9 plug
Conductor cross section	
	flexible 0.2 mm <sup>2</sup> ... 2.5 mm <sup>2</sup>
	AWG 24 AWG ... 12 AWG
Serial transmission speed	1.2; 2.4; 4.8; 7.2; 9.6; 19.2; 31.25; 38.4; 57.6; 75; 93.75; 115.2 kbps
Transmission length	15 m (shielded twisted pair)
Protocols supported	transparent protocol
Pin assignment	DTE/DCE switchover via switch
<b>RS-422 interface in acc. with ITU-T V.11, EIA/TIA-422, DIN 66348-1</b>	
Connection method	Pluggable screw connection
Conductor cross section	
	flexible 0.2 mm <sup>2</sup> ... 2.5 mm <sup>2</sup>
	AWG 24 AWG ... 13 AWG
Termination resistor	390 Ω - 150 Ω - 390 Ω
Serial transmission speed	1.2; 2.4; 4.8; 9.6; 19.2; 38.4; 57.6; 75; 93.75; 115.2 kbps
Transmission length	1200 m (shielded twisted pair)
Protocols supported	transparent protocol

**RS-485 interface in acc. with EIA/TIA-485, DIN 66259-1**

Connection method	Pluggable screw connection
Conductor cross section	
	flexible 0.2 mm <sup>2</sup> ... 2.5 mm <sup>2</sup>
	AWG 24 AWG ... 14 AWG
Data direction switching	Automatic control or via RTS/CTS
Termination resistor	390 Ω - 150 Ω - 390 Ω
Serial transmission speed	1.2; 2.4; 4.8; 9.6; 19.2; 38.4; 57.6; 75; 93.75; 115.2 kbps
Transmission length	1200 m (shielded twisted pair)
Protocols supported	transparent protocol

**General data**

Degree of protection	IP20
Degree of pollution	2
Dimensions (W/H/D)	22.5 mm x 99 mm x 114.5 mm
Housing material	PA 6.6-FR green
Free fall in acc. with IEC 60068-2-32	1 m
Vibration resistance in acc. with EN 60068-2-6/ IEC 60068-2-6	5g, 10...150 Hz, 2.5 h, in XYZ direction
Shock in acc. with EN 60068-2-27/IEC 60068-2-27	25g, 11 ms period, half-sine shock pulse
Bit distortion	≤ 5 %
Bit delay	≤ 2.5 μs
Noise emission according to	EN 50 081-1
Noise immunity according to	EN 50 082-2
Electromagnetic compatibility	Conformance with EMC Directive 2014/30/EU

**MTTF (mean time to failure)**

SN 29500 standard, temperature 25°C, operating cycle 21%	1654 Years
SN 29500 standard, temperature 40°C, operating cycle 34.25%	746 Years
SN 29500 standard, temperature 40°C, operating cycle 100%	310 Years

**Ambient conditions**

Ambient temperature	
	Operation -40 °C ... 70 °C
	Storage/transport -40 °C ... 85 °C
Humidity	
	Operation 10 % ... 95 % (non-condensing)
Altitude	≤ 5000 m (For restrictions, see the manufacturer's declaration for altitude operation)

**Conformance/Approvals**

CE	CE-compliant
EAC	EAC
ATEX Please follow the special installation instructions in the documentation!	⊕ II 3 G Ex nA IIC T4 Gc IBExU16ATEXB004 X
IECEX	Ex nA IIC T4 Gc IECEX IBE 15.0034X
UL, USA/Canada	508 Recognized Class I, Div. 2, Groups A, B, C, D Class I, Zone 2, AEx nA IIC T4 Class I, Zone 2, Ex nA IIC T4 Gc X
Corrosive gas test	ISA-S71.04-1985 G3 Harsh Group A
Shipbuilding	DNV GL ABS
Temperature	B
Humidity	A
Vibration	A
EMC	B
Enclosure	Required protection according to the Rules shall be provided upon installation on board

**Conformance with EMC Directive 2014/30/EU****Noise immunity according to EN 61000-6-2**

Electrostatic discharge	EN 61000-4-2	
	Contact discharge	± 6 kV (Test Level 3)
	Discharge in air	± 8 kV (Test Level 3)
	Comments	Criterion B
Electromagnetic HF field	EN 61000-4-3	
	Frequency range	26 MHz ... 3 GHz (Test Level 3)
	Field intensity	10 V/m
	Comments	Criterion A
Fast transients (burst)	EN 61000-4-4	
	Input	± 2.2 kV (Test Level 3)
	Signal	± 2.2 kV (Test Level 3)
	Comments	Criterion B
Surge current loads (surge)	EN 61000-4-5	
	Input	± 0.5 kV (DC supply)
	Signal	± 1 kV (Data line, asymmetrical)
	Comments	Criterion B
Conducted interference	EN 61000-4-6	
	Frequency range	0.15 MHz ... 80 MHz
	Voltage	10 V
	Comments	Criterion A

**Emitted interference in acc. with EN 61000-6-4**

Interference emission EN 55011  
Class A, industrial applications

Criterion A Normal operating behavior within the specified limits

Criterion B Temporary impairment of operating behavior that is corrected by the device itself

## 5 Safety notes

### 5.1 Installation notes



**WARNING:**

Observe the following safety notes when using the device.

- The category 3 device is designed for installation in zone 2 potentially explosive areas. It meets the requirements of EN 60079-0:2012+A11:2013 and EN 60079-15:2010.
- Installation, operation, and maintenance may only be carried out by qualified electricians. Follow the installation instructions as described.
- When installing and operating the device, the applicable regulations and safety directives (including national safety directives), as well as general technical regulations, must be observed. The technical data is provided in the package slip and on the certificates (conformity assessment, additional approvals where applicable).
- Changing or modifying the device beyond the configuration is not permitted. Do not repair the device yourself; replace it with an equivalent device. Repairs may only be performed by the manufacturer. The manufacturer is not liable for damage resulting from noncompliance.
- The IP20 degree of protection (IEC/EN 60529) specifies that the device is intended for use in a clean and dry environment. Do not subject the device to mechanical and/or thermal stress that exceeds the specified limits.
- The device is designed exclusively for SELV operation according to IEC 60950-1/EN 60950-1/VDE 0805. The device may only be connected to devices, which meet the requirements of EN 60950-1.

### 5.2 Installation in Zone 2



**WARNING: Explosion hazard when used in potentially explosive areas**

Please make sure that the following notes and instructions are observed.

- Use in potentially explosive areas is not permitted in China.
- Observe the specified conditions for use in potentially explosive areas.
- The devices must be installed in a housing which is designed in a type of protection in accordance with EN 60079-0, section 1 and has a minimum protection rating of IP54.
- In zone 2, only connect devices to the supply and signal circuits that are suitable for operation in the Ex zone 2 and the conditions at the installation location.
- The switches of the device that can be accessed may only be actuated when the power supply to the device is disconnected.
- The device must be stopped and immediately removed from the Ex area if it is damaged, was subject to an impermissible load, stored incorrectly or if it malfunctions.
- In potentially explosive areas, terminals may only be snapped onto or off the DIN rail connector and wires may only be connected or disconnected when the power is switched off.
- The device is not designed for use in atmospheres with a danger of dust explosions.
- D-SUB interfaces may only be connected or disconnected when the voltage is disconnected. Screw the D-SUB mounting screws tight on all connectors.



### 5.3 UL notes



**WARNING: Explosion hazard when used in potentially explosive areas**

Please make sure that the following notes and instructions are observed.

**PROCESS CONTROL EQUIPMENT FOR HAZARDOUS LOCATIONS 31ZN**

- A) All wiring of these devices must be in accordance with the national electric code article 501.4(B) for Class 1, Division 2.
- B) Product must be installed in Class I, Zone 2 certified at least an IP54 enclosure.
- C) Product must be used in no more than a pollution degree 2 environment as defined by IEC 60664-1
- D) Provisions must be made to provide transient protection to the product so that voltage levels do not exceed 40% of the rated voltage at the power supply terminals.

Wire Range: 30-12 AWG,

Torque: 5-7 Lbs-Ins

Supply voltage range 24 V DC  $\pm 20\%$   $\leq 85$  mA

## 6 Transport and unpacking

- Check the delivery for visible damage caused by transportation.
- Submit claims for any transport damage immediately. Inform Phoenix Contact or your supplier as well as the shipping company without delay.
- Read the complete packing slip carefully.
- Retain the packing slip.
- Keep the packaging for a possible later transport.

## 7 Application examples

### 7.1 RS-232 // RS-485

The RS-485 standard allows more than two devices to communicate with one another. By converting the RS-232 point-to-point interface into the bus-capable RS-485 standard, you can network up to 32 devices via a 2 or 4-wire cable.

Figure 1 Interface adaptation or programming connection

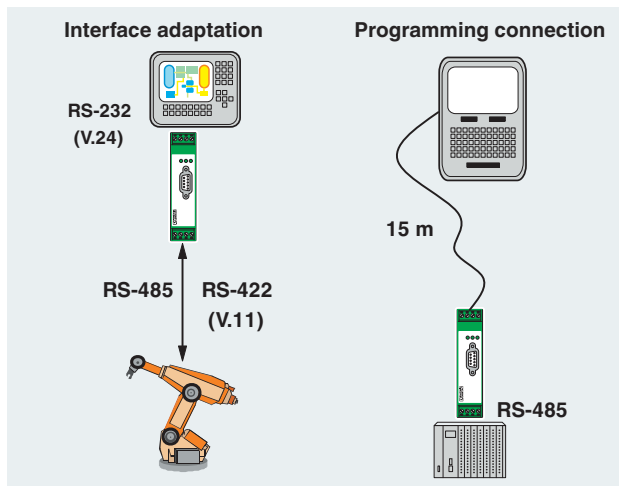

Figure 2 Master interface connection

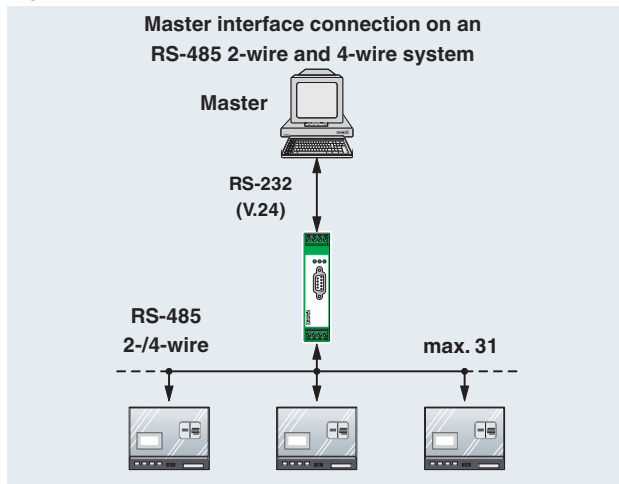
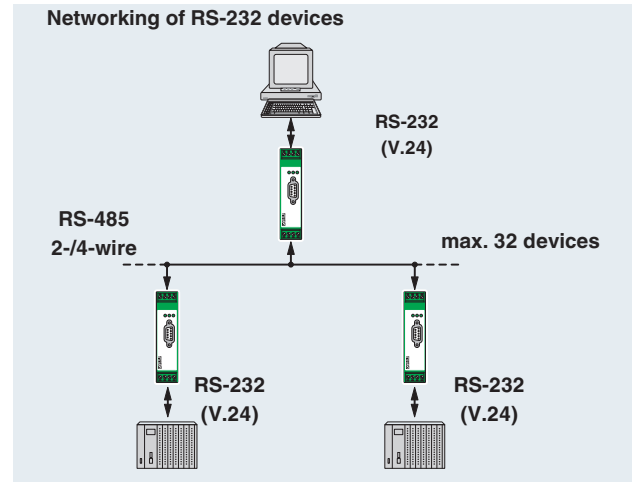

Figure 3 Networking of RS-232 devices



### 7.2 RS-232 // RS-422

You can use the RS-422 standard to implement rapid, interference-free point-to-point connections in industrial applications. Connections covering a distance of up to 1200 m can be established using a shielded, twisted pair 4-wire cable.

Figure 4 Point-to-point connection between two RS-232 interfaces via RS-422

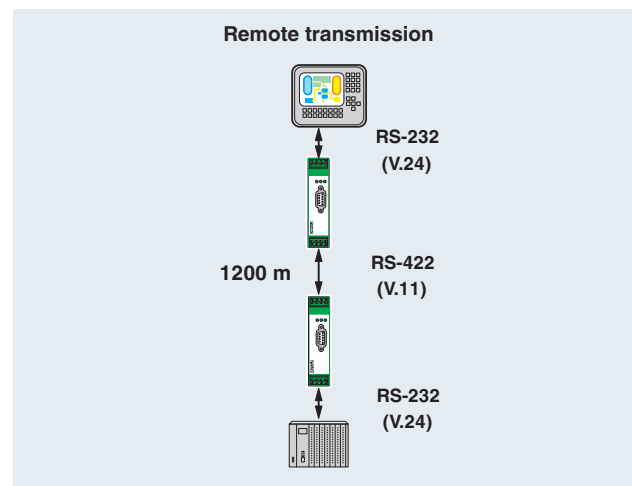

## 8 Product description

Figure 5 Housing dimensions

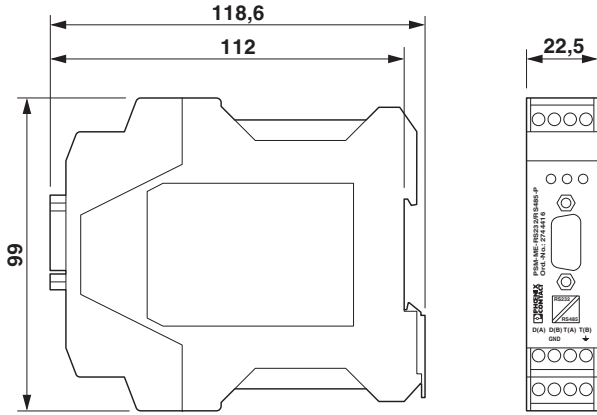

Figure 6 Basic circuit diagram

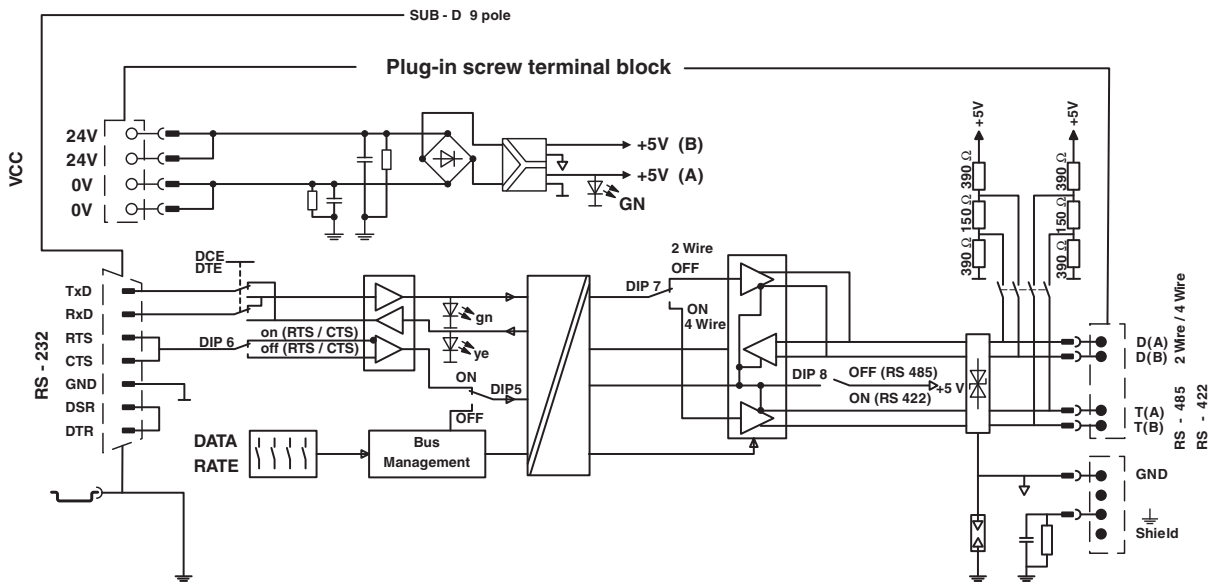
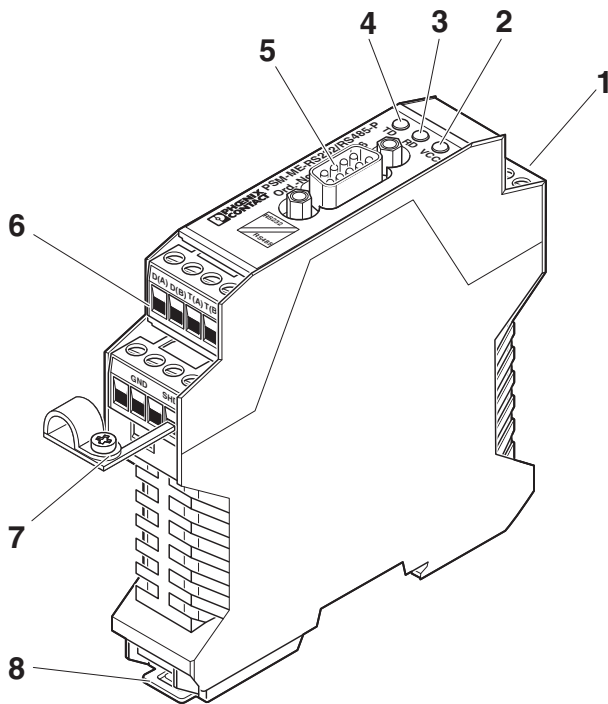

Figure 7 Function elements



**COMBICON plug-in screw terminal blocks**

- 1 Power supply (pin 1 + pin 3)
- 6 RS-485/422 interface

**D-SUB pin strip**

- 5 RS-232 interface

**Diagnostics and status indicators**

- 2 VCC (green) Supply voltage
- 3 RD (green) RS-232 Data received
- 4 TD (yellow) RS-232 Data transmission

**Operating elements**

- 7 Shield connection clamp
- 8 Locking latch for DIN rail mounting

**9 RS-232 interface**

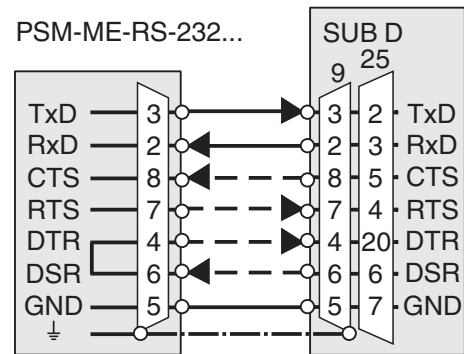

Figure 8 RS-232 interface

Pin	D-SUB 9	Designation
3	TxD	Transmit data
2	RxD	Receive data
8	CTS	Clear to send
7	RTS	Request to send
5	GND	Operating ground
4	DTR	DTE ready
6	DSR	Ready to operate
Shield	⏚	Shield connection

- Establish a 1:1 connection between the RS-232 interface of the interface converter and the I/O device.
- Note:** The minimum configuration only requires one connection for TxD, RxD and GND (software handshake)!
- Plug the 9-pos. D-SUB connector onto the device.

### 9.1 Configuration

You must open the housing to access the DIP switches and slide switches.



**NOTE: electrostatic discharge!**

Electrostatic discharge can damage or destroy components.

- When handling the device, observe the necessary safety precautions against electrostatic discharge (ESD) according to EN 61340-5-1 and IEC 61340-5-1.

- Disengage the housing cover with a screwdriver (A).
- Carefully pull the PCB out of the housing as far as possible.

Figure 9 Opening the housing

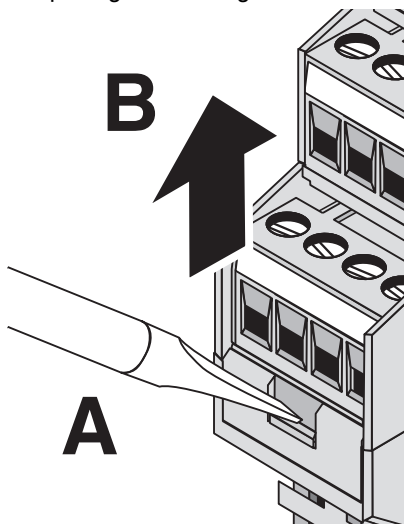
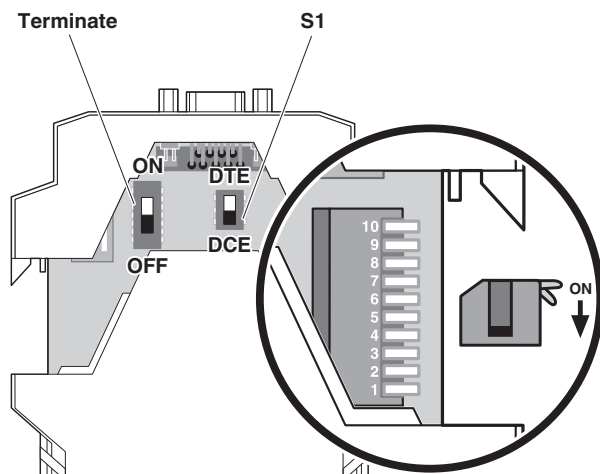

Figure 10 Remove the PCB



### 9.2 DTE/DCE adjustment

The TxD and RxD can be crossed internally via the S1 DTE/DCE slide switch so that you are able to conveniently adapt to DTE or DCE interfaces.

- When connecting a DTE device (Data Terminal Equipment), slide the S1 switch to the DTE position.
- When connecting a DCE device (Data Communication Equipment) slide the S1 switch to the DCE position.



If the connected interface type is not known, you can determine the right configuration by **testing** the S1 DTE /DCE-slide switch.

### 9.3 RTS/CTS support (DIP 5)

During normal operations no control lines (RTS/CTS) are required for data direction switches (DIP5 = OFF).

Alternatively, data direction can be controlled via the RTS/CTS lines. If this is required, set DIP switch 5 to ON.

**Function**

- RTS/CTS -3 V ... -15 V = RS-485 reception mode
- +3 V ... +15 V = RS-485 transmission mode

### 9.4 RTS/CTS inversion (DIP 6)

It is occasionally necessary to invert the control lines. To do so, set DIP switch 6 to "ON".

**Function (inverted mode)**

- RTS/CTS +3 V ... +15 V = RS-485 reception mode
- 3 V ... -15 V = RS-485 transmission mode

Figure 11 DIP switches 5 ... 8

	DIP					
	5	6	7	8	9	10
Self-controlled						
RTS/CTS controlled	•					
RTS/CTS standard						
RTS/CTS invers	•					
RS-485 2-wire						
RS-485 4-wire			•			
RS-485						
RS-422				•		

## 10 Operation as RS-485 2-wire interface

- Set DIP switch 8 to OFF to activate RS-485 operating mode.
- Set DIP switch 7 to OFF to activate 2-wire mode.
- Choose the interface type of the RS-232 interface with the DTE/DCE-slide switch and the operating mode with DIP switches 5 and 6. If you choose self-controlled operating mode (DIP 5= OFF), no RS-232 interface control lines are required.

Figure 12 DIP switches 5 ... 8

	DIP					
	5	6	7	8	9	10
Self-controlled	ON $\hat{=}$ <input type="checkbox"/>					
RTS/CTS controlled	<input checked="" type="checkbox"/>					
RTS/CTS standard						
RTS/CTS invers		<input checked="" type="checkbox"/>				
RS-485 2-wire						
RS-485 4-wire			<input checked="" type="checkbox"/>			
RS-485						
RS-422				<input checked="" type="checkbox"/>		

- For self-controlled operational mode only (DIP 5 = OFF): set transmission speed using DIP switches 1-4.

ON = <input checked="" type="checkbox"/>	DIP 1	DIP 2	DIP 3	DIP 4
<b>Data rate [kbps]</b>				
115.2		<input checked="" type="checkbox"/>		<input checked="" type="checkbox"/>
93.75		<input checked="" type="checkbox"/>	<input checked="" type="checkbox"/>	
75		<input checked="" type="checkbox"/>	<input checked="" type="checkbox"/>	<input checked="" type="checkbox"/>
57.6	<input checked="" type="checkbox"/>			
38.4	<input checked="" type="checkbox"/>			<input checked="" type="checkbox"/>
19.2	<input checked="" type="checkbox"/>		<input checked="" type="checkbox"/>	<input checked="" type="checkbox"/>
9.6	<input checked="" type="checkbox"/>		<input checked="" type="checkbox"/>	<input checked="" type="checkbox"/>
4.8	<input checked="" type="checkbox"/>	<input checked="" type="checkbox"/>		
2.4*	<input checked="" type="checkbox"/>	<input checked="" type="checkbox"/>		<input checked="" type="checkbox"/>
1.2*	<input checked="" type="checkbox"/>	<input checked="" type="checkbox"/>	<input checked="" type="checkbox"/>	

\* Transmission speeds of 1.2 kbps and 2.4 kbps are available as of hardware/firmware (HW/FW) Version 20/400.



Set all interface converters and bus devices to the same transmission speed.

- If necessary, activate the termination resistors (see "Termination resistor for RS-485/422 interface").

- To couple two RS-485 interfaces connect them using a twisted wire pair. GND connection is recommended but is not absolutely necessary.



### NOTE: Interference

Use shielded twisted pair data cables. Connect the cable shielding at both ends of the transmission path.

Figure 13 RS-485 2-wire interface

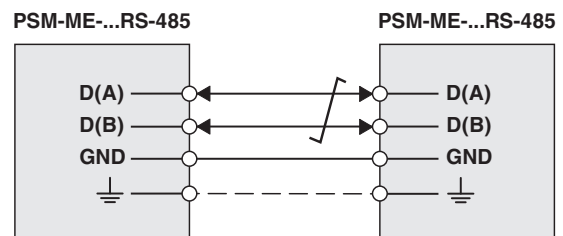

Terminal point	Designation
D(B)	Data line +
D(A)	Data line -
GND	Operating ground
$\perp$	Shield connection

- For the shield connection, use the provided shield connection clamp.

Figure 14 Install shield connection clamp

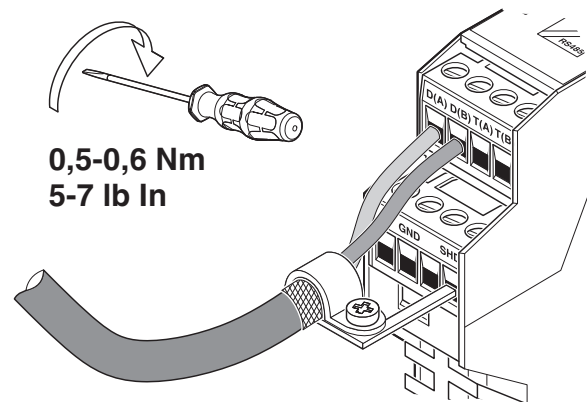

## 11 Operation as RS-485 4-wire interface

- Set DIP switch 8 to OFF to activate RS-485 operating mode.
- Set DIP switch 7 to ON to activate 4-wire mode.
- Choose the interface type of the RS-232 interface with the DTE/DCE-slide switch and the operating mode with DIP switches 5 and 6. If you choose self-controlled operating mode (DIP 5= OFF), no RS-232 interface control lines are required.

Figure 15 DIP switches 5 ... 8

	DIP					
	5	6	7	8	9	10
Self-controlled						
RTS/CTS controlled	•					
RTS/CTS standard						
RTS/CTS invers	•					
RS-485 2-wire						
RS-485 4-wire			•			
RS-485						
RS-422						•

- For self-controlled operational mode only (DIP 5 = OFF): set transmission speed using DIP switches 1-4.

ON = •	DIP 1	DIP 2	DIP 3	DIP 4
<b>Data rate [kbps]</b>				
115.2		•	•	•
93.75		•	•	•
75		•	•	•
57.6	•			
38.4	•			•
19.2	•		•	
9.6	•		•	•
4.8	•	•		
2.4*	•	•		•
1.2*	•	•	•	

\* Transmission speeds of 1.2 kbps and 2.4 kbps are available as of hardware/firmware (HW/FW) Version 20/400.



Set all interface converters and bus devices to the same transmission speed.

- If necessary, activate the termination resistors (see "Termination resistor for RS-485/422 interface").

- To couple two RS-485 interfaces connect them using a twisted wire pair. Ensure in connection that the transmission and reception lines are crossed. GND connection is recommended but is not absolutely necessary.



### NOTE: Interference

Use shielded twisted pair data cables. Connect the cable shielding at both ends of the transmission path.

Figure 16 RS-485 4-wire interface

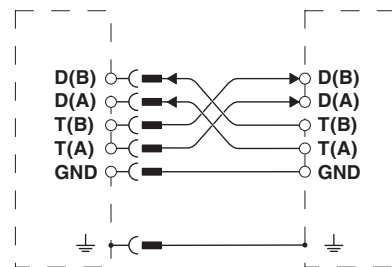

Terminal point	Designation
D(B)	Receive data +
D(A)	Receive data -
T(B)	Transmit data +
T(A)	Send data -
GND	Operating ground
⏏	Shield connection

- For the shield connection, use the provided shield connection clamp.

Figure 17 Install shield connection clamp

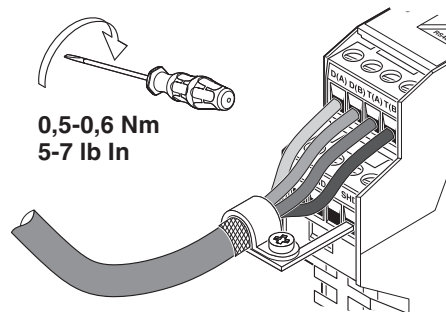

0,5-0,6 Nm  
5-7 lb In

## 12 Operation as RS-422 interface

- Set DIP switch 8 to ON to activate RS-422 operating mode.
- Choose the interface type of the RS-232 interface with the DTE/DCE-slide switch and the operating mode with DIP switches 5 and 6. If you choose self-controlled operating mode (DIP 5= OFF), no RS-232 interface control lines are required.

Figure 18 DIP switches 5 ... 8

	DIP					
	5	6	7	8	9	10
Self-controlled						
RTS/CTS controlled	•					
RTS/CTS standard						
RTS/CTS invers	•					
RS-485 2-wire						
RS-485 4-wire		•				
RS-485						
RS-422				•		

- Activate the termination resistors with slide switch RS-485/RS-422 TERMINATE.
- To couple two RS-422 interfaces, use a twisted wire pair. Ensure that the transmission and reception leads are crossed. GND connection is recommended but not absolutely necessary.



**NOTE: Interference**

Use shielded twisted pair data cables. Connect the cable shielding at both ends of the transmission path.

Figure 19 RS-422 interface

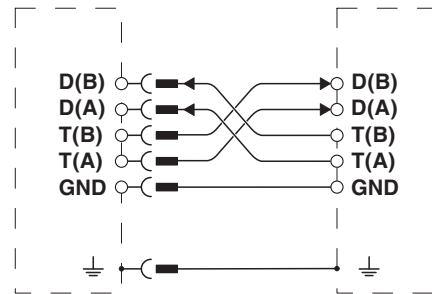

Terminal point	Designation
D(B)	Receive data +
D(A)	Receive data -
T(B)	Transmit data +
T(A)	Send data -
GND	Operating ground
⊥	Shield connection

- For the shield connection, use the provided shield connection clamp.

Figure 20 Install shield connection clamp

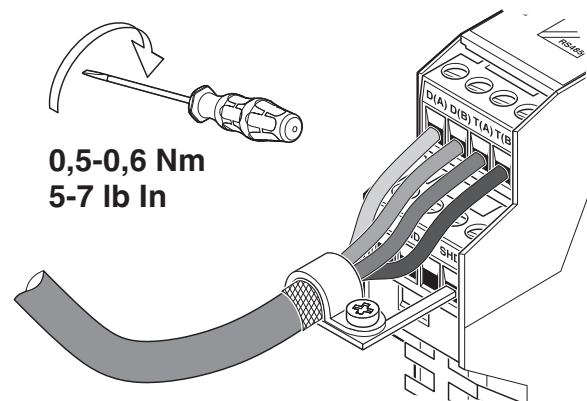



### 13 Termination resistor for RS-485/422 interface

To terminate the bus line the converter incorporates a connectable termination resistor. Activate the termination resistor by setting the RS-485/RS-422 TERMINATE slide switch to ON.

Figure 21 Remove the PCB

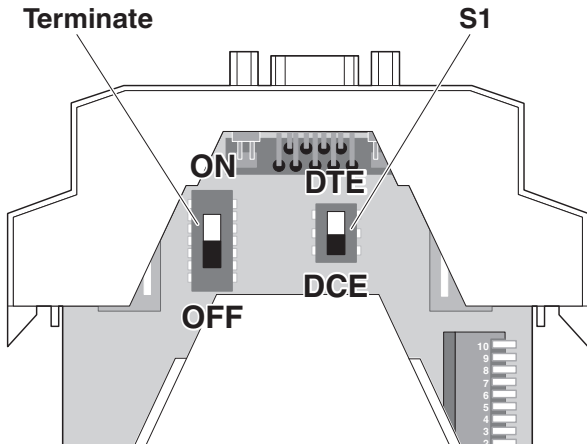

**RS-485:** Activate the termination resistors at the two furthest ends of the bus.

**RS-422:** Activate all termination resistors.

Figure 22 Activate termination resistors - RS-485

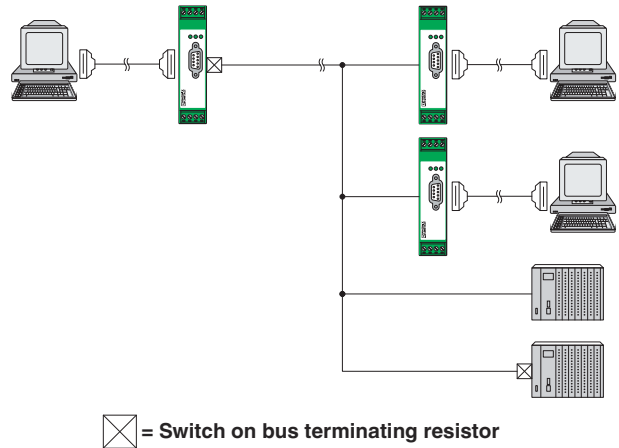
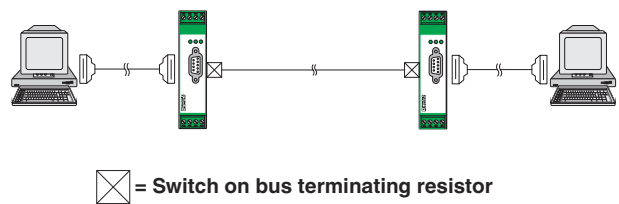

Figure 23 Activate termination resistors - RS-422



## 14 Installation



### CAUTION: Electric shock

The device is only intended for operation with SELV according to IEC 60950/EN 60950/VDE 0805.



### NOTE: Malfunction

Connect the DIN rail to protective earth ground using a grounding terminal block. The device is grounded when it is snapped onto the DIN rail. This ensures the integrated surge protection is functional and that the shielding of the data cable is effective.

### 14.1 Mounting

Figure 24 Mounting on a DIN rail

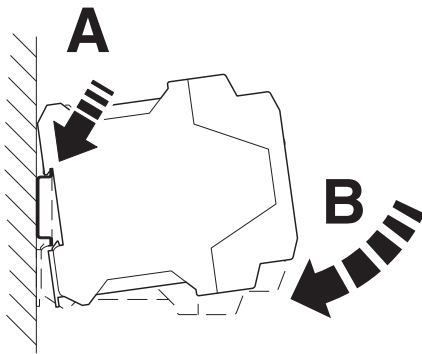

- To avoid contact resistance, only use clean, corrosion-free 35 mm DIN rails according to DIN EN 60715.
- Install an end bracket next to the left-hand device to prevent the devices from slipping.
- Place the device onto the DIN rail from above. Push the module from the front toward the mounting surface until it audibly engages.

### 14.2 Removal

Figure 25 Removal

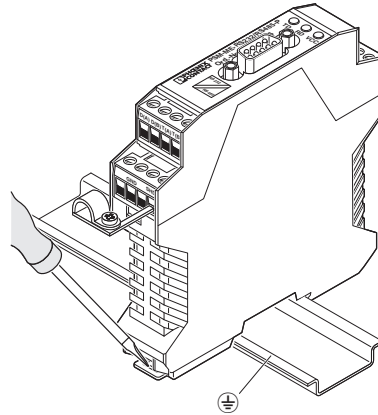

- Push down the locking tab with a screwdriver, needle-nose pliers or similar.
- Slightly pull the bottom edge of the device away from the mounting surface.
- Pull the device away from the DIN rail.

### 14.3 Connecting the supply voltage

The device is supplied with 24 V DC or AC.

Figure 26 Connecting the supply voltage

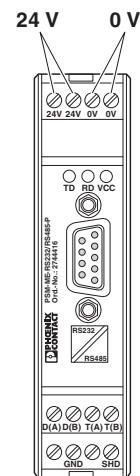

- Provide supply voltage to the device via terminal 1 (pin 1 and pin 3).

## 15 Disposal



Dispose of the device separately from other waste, i.e., via an appropriate collection site.