

Baureihe: **STS**
 Type:
 Art.-Nr.: **STS 20/4/23**
 Art.-No.:

Datenblatt
 Technical
 Specifications

BLOCK
 Transformatoren-Elektronik
 GmbH
 D - 27283 Verden/Aller

Kennzeichnung:
 Marking

	STS 20/4/23	20VA/42VA
	ta.40°C CL.B	50-60Hz
	Pri: 400V ±20V - 69mAac	UL class 105
	Sec: 230V - 87mAac	0,080AT
www.block.eu	Fa.Nr.:	

	STS 20/4/23	
VDE0570 TypS	Type EI66/23/A	

Anschlußkennzeichnung:
 Terminal Identification

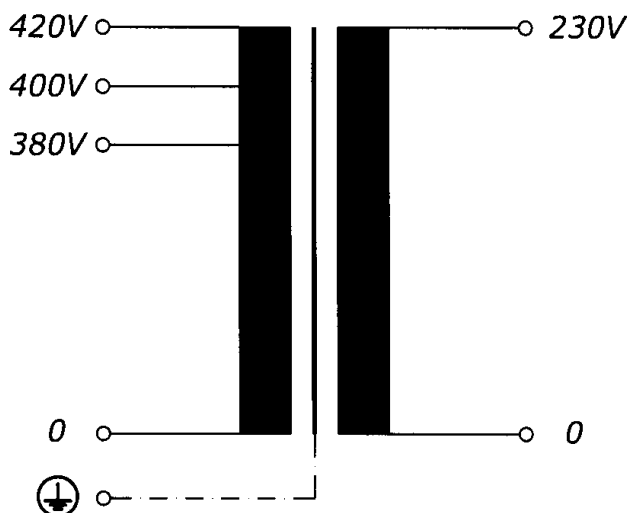

Abmessungen:
 Dimensions

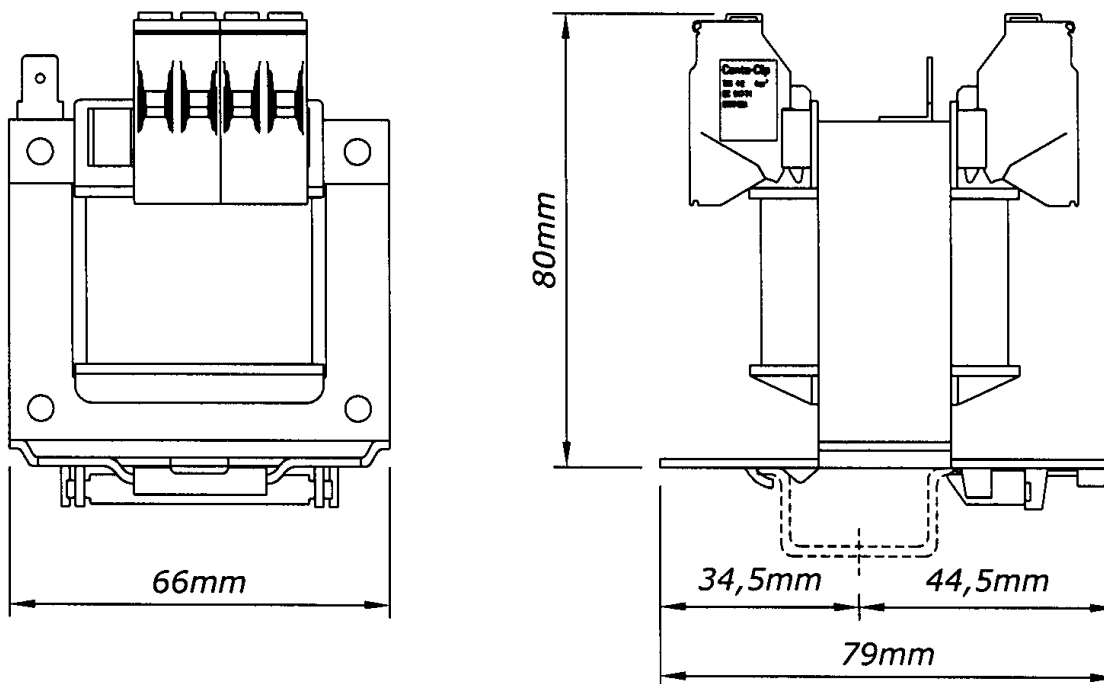

Gewicht: ca. 0,66kg
 Weight: approx. 0,66kg

Befest.loch= Tragschienenmontage nach DIN 50022
 Mounting hole panel installation on mounting rails to DIN 50022

Seite 2/2
 Page 2/2

Schutzvermerk nach ISO 16016 beachten
 Observe protection clause to ISO 16016

Änderungen vorbehalten
 Subject to change