

# *BishopWisecarver*

**DUAL**  **VEE**  
single edge slide  
system



**HEPCO**<sup>®</sup>  
[www.HepcoMotion.com](http://www.HepcoMotion.com)

## Contents

	<b>Page</b>
<b>Introducing DualVee Technology</b> _____	<b>2</b>
<b>Guide Wheel Overview</b> _____	<b>3</b>
<b>Guide Wheels</b> _____	<b>4</b>
<b>Guide Wheel Load Capacities</b> _____	<b>5</b>
<b>Studded Guide Wheels</b> _____	<b>6</b>
<b>Track Sizes and Specification</b> _____	<b>7</b>
<b>Single Edge Track</b> _____	<b>8</b>
<b>Double Edge Track</b> _____	<b>9</b>
<b>Bushings</b> _____	<b>10</b>
<b>Support Bushings</b> _____	<b>11</b>
<b>Wheel Covers</b> _____	<b>12</b>
<b>Lubricator Assemblies</b> _____	<b>13</b>
<b>Mounting Dimensions/Formulae</b> _____	<b>14</b>
<b>DualVee Overview</b> _____	<b>15-18</b>
<b>Quick Ordering Procedure</b> _____	<b>19</b>
<b>Notes</b> _____	<b>19-20</b>
<b>Full Size Drawings</b> _____	<b>21</b>

# Introducing DualVee Motion Technology

DualVee Motion Technology™ (DMT) includes a wide range of components and guide wheels which are used in the construction of antifriction, linear guidance mechanisms. DMT is a rugged yet cost effective linear bearing technology and is available in various options to suit a wide range of applications. Light duty applications in clean rooms to rugged transport systems working in hostile conditions can all benefit from DMT technology.

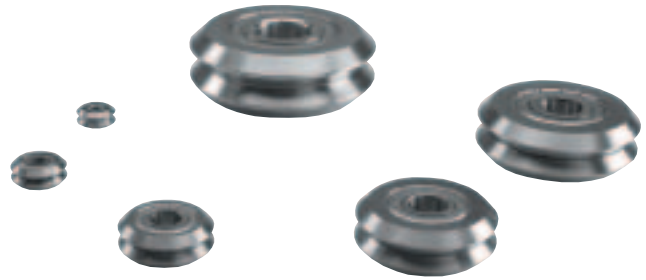

## DualVee Features and Benefits



CAD CD available

- **PROVEN TECHNOLOGY/HIGH RELIABILITY**
- **BROAD PRODUCT RANGE**
- **FLEXIBILITY AND SIMPLICITY IN DESIGN**
- **LOW INSTALLED COST**
- **SMOOTH, ANTIFRICTION OPERATION**
- **LOW NOISE/LOW VIBRATION**
- **HIGH SPEED CAPACITY**
- **IMPERVIOUS TO CONTAMINATED ENVIRONMENTS**
- **LONG STROKE LENGTHS**
- **EASY INSTALLATION AND MAINTENANCE**
- **LOW PROFILE**

## Guide Wheel Overview

- Double row angular contact bearing arrangement.
- Available in six standard sizes.
- Stainless or carbon steel configurations available from stock.
- Clean room and high temperature configurations.
- Available either shielded or sealed to accommodate required level of protection.
- Either inside or outside Vee surface can be employed to support loads.

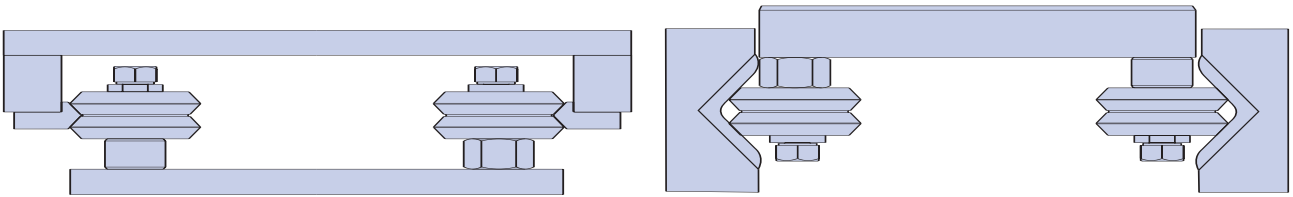

**Figure 1** DualVee configurations showing use of inside and outside Vee surfaces.



**Figure 2** DualVee Motion Technology (left) vs. alternative recirculating bearing technologies (right).

### Notes:

Recirculating elements in DualVee guide wheels are self-contained and isolated from the environment; rolling contact between wheel and track sweeps debris aside making DualVee ideal for use in contaminated applications. Alternative round and square rail linear guides have recirculating elements directly in contact with the rail's bearing surface, making shielding of the ball path region difficult; these alternative bearing technologies often require bellows or other costly methods of protection to prevent the ingress of contaminants which leads to catastrophic failure.

## Guide Wheels

- Use with standard profile or low profile bushings, pages 10/11

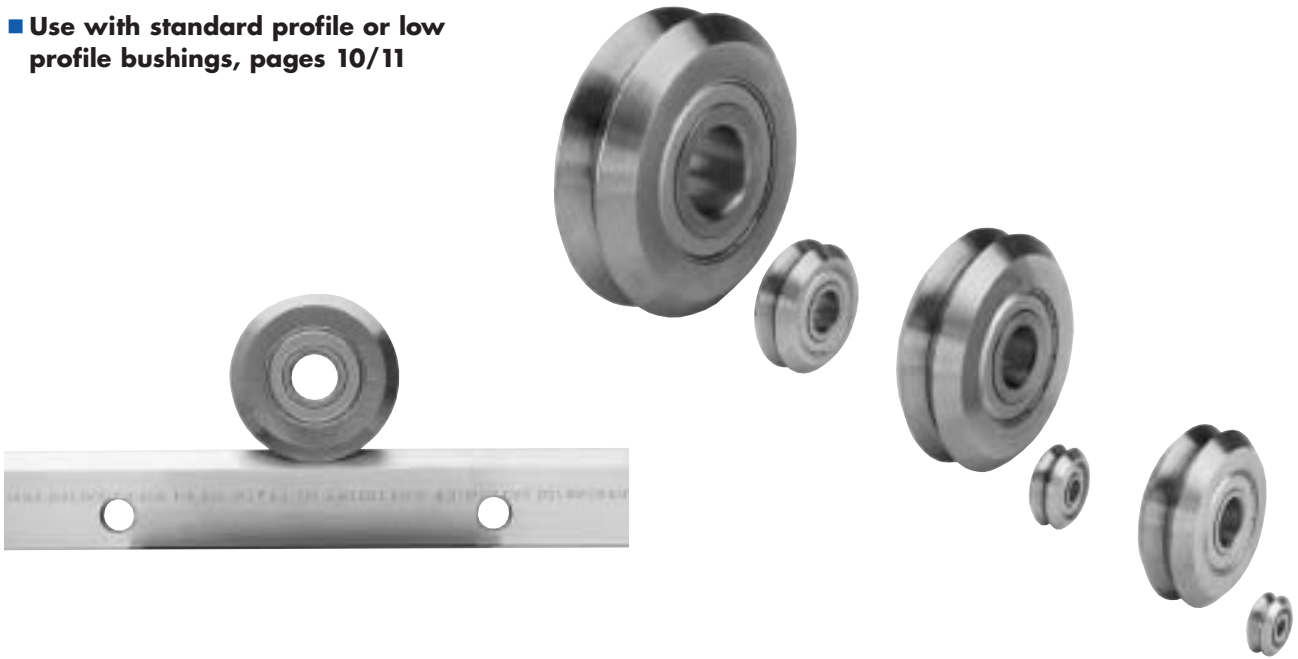

Part Number	DIMENSIONS <sup>3,8</sup>					MATERIALS							
	Outside Diameter A	Width B	Bore Size C	Inside Vee Radius MDw Inside	Outside Vee Radius MDw Outside	Outside Race <sup>5</sup>	Inner Race <sup>5</sup>	Ball <sup>5</sup>	Retainer <sup>1</sup>	Shield <sup>1</sup>	Seal <sup>2</sup>	Grease <sup>4</sup>	
W1	19.58	7.87	4.76	7.95	11.89	52100	52100	52100	Nylon 66	A591	None	Alvania 2	
W2	30.73	11.13	9.53	12.70	18.26	52100	52100	52100	Nylon 66	A591	None	Alvania 2	
W3	45.80	15.88	12.00	19.05	27.00	52100	52100	52100	Nylon 66	A591	None	Alvania 2	
W4	59.94	19.05	15.00	25.40	34.93	52100	52100	52100	Nylon 66	A591	None	Alvania 2	
W0X	14.83	6.35	4.00	5.94	9.12	52100	52100	52100	304	A591	NBR	Alvania 2	
W1X	19.58	7.87	4.76	7.95	11.89	52100	52100	52100	Nylon 66	A591	NBR	Alvania 2	
W2X	30.73	11.13	9.53	12.70	18.26	52100	52100	52100	Nylon 66	A591	NBR	Alvania 2	
W3X	45.80	15.88	12.00	19.05	27.00	52100	52100	52100	Nylon 66	A591	NBR	Alvania 2	
W4X	59.94	19.05	15.00	25.40	34.93	52100	52100	52100	Nylon 66	A591	NBR	Alvania 2	
W4XXL	75.39	25.40	22.00	31.75	44.45	52100	52100	52100	Nylon 66	A591	NBR	Alvania 2	
W1SSX	19.58	7.87	4.76	7.95	11.89	440C	440C	440C	Nylon 66	304	NBR	Alvania 2	
W2SSX	30.73	11.13	9.53	12.70	18.26	440C	440C	440C	Nylon 66	304	NBR	Alvania 2	
W3SSX	45.80	15.88	12.00	19.05	27.00	440C	440C	440C	Nylon 66	304	NBR	Alvania 2	
W4SSX	59.94	19.05	15.00	25.40	34.93	440C	440C	440C	Nylon 66	304	NBR	Alvania 2	
W4SSXXL	75.39	25.40	22.00	31.75	44.45	440C	440C	440C	Nylon 66	304	NBR	Alvania 2	
W0SSCR <sup>7</sup>	14.83	6.35	4.00	5.94	9.12	440C	440C	440C	304	304	None	Krytox227	
W1SS227 <sup>6,7</sup>	19.58	7.87	4.76	7.95	11.89	440C	440C	440C	304	304	None	Krytox227	
W2SS227 <sup>6,7</sup>	30.73	11.13	9.53	12.70	18.26	440C	440C	440C	304	304	None	Krytox227	
W3SS227 <sup>6,7</sup>	45.80	15.88	12.00	19.05	27.00	440C	440C	440C	304	304	None	Krytox227	
W4SSCR <sup>7</sup>	59.94	19.05	15.00	25.40	34.93	440C	440C	440C	304	304	None	Krytox227	

### Notes:

1. "A591" shield material (JIS SECC) is cold rolled carbon steel with electrolytic zinc coating (classified by ASTM A591). "304" reflects 304 stainless steel.
2. "NBR" seal material is nitrile butadiene rubber.
3. All dimensions in mm unless otherwise indicated.
4. "Krytox GPL 227" is a DuPont product. "Alvania # 2" is a Shell Oil product.
5. "52100" reflects hardened AISI 52100 bearing steel (Rc 60-62); "440C" reflects hardened AISI 440C stainless steel (Rc 58-60).
6. High Temperature Compatible – Heat stabilized components allow for operating temperatures to 260°C.
7. Clean Room Compatible – All stainless steel components are internally lubricated with Krytox GPL 227.
8. Guide wheels are manufactured to ABEC class 5 tolerances.

# Guide Wheel Load Capacities

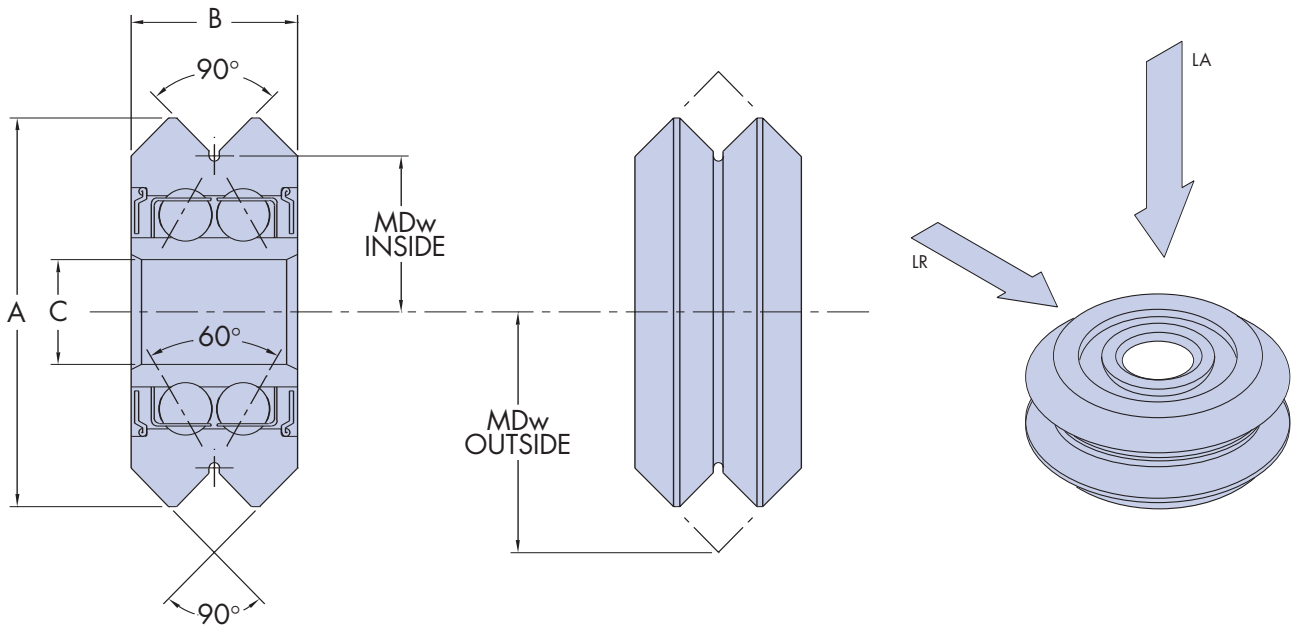

LOAD CAPACITY (N)						
Part Number	Radial Working Load Capacity LRmax (N) <sup>2</sup>	Axial Working Load Capacity LAmax (N) <sup>2</sup>	BDLR <sup>1</sup> Radial (N)	BSLR <sup>1</sup> Radial (N)	BDLR <sup>1</sup> Axial (N)	BSLR <sup>1</sup> Axial (N)
W1	595	252	2180	1110	1090	1040
W2	1431	625	4700	2780	2380	2630
W3	3074	1701	9150	5050	4500	4800
W4	4704	4001	12800	7900	6350	7450
W0X	265	123	1050	500	530	470
W1X	595	252	2180	1110	1090	1040
W2X	1431	625	4700	2780	2380	2630
W3X	3074	1701	9150	5050	4500	4800
W4X	4704	4001	12800	7900	6350	7450
W4XXL	7571	6552	20600	14300	10400	13500
W1SSX	595	252	2180	1110	1090	1040
W2SSX	1431	625	4700	2780	2380	2630
W3SSX	3074	1701	9150	5050	4500	4800
W4SSX	4704	4001	12800	7900	6350	7450
W4SSXXL	7571	6552	20600	14300	10400	13500
W0SSCR	220	102	872	415	440	390
W1SS227	494	208	1810	920	900	870
W2SS227	1188	520	3900	2310	1980	2180
W3SS227	2554	1399	7600	4200	3700	4000
W4SSCR	3896	3320	10600	6560	5270	6180

## Notes:

1. The BDLR (Basic Dynamic Load Rating) and BSLR (Basic Static Load Rating) are according to AFBMA STD 9-1990. These ratings are based on industry standard bearing calculations and are for comparison to other products as measured against the same standard. Working load capacities should be used for component sizing and selection.
2. Sizing and selection should be based on working load capacity ratings according to the sizing guidelines presented in the technical reference section (see load/life relationship, pages 15/16). Working load capacities reflect lubricated wheel/track interface.

# Studded Guide Wheels

- DualVee guide wheels with integral stud<sup>2</sup> and mounting hardware.
- Easy installation/available from stock.
- Consolidates multiple components into one part number, making procurement simple.
- Choose from a wide range of standard available guide wheels<sup>7,8</sup>.

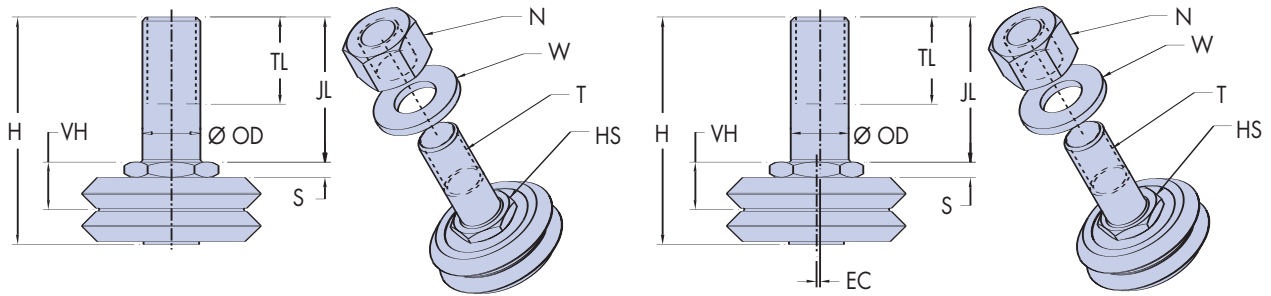

STUDED GUIDE WHEEL DIMENSIONS <sup>1</sup>												
DualVee Size	Assembly Part Number	Guide Wheel <sup>7</sup> Used	Offset EC <sup>5</sup>	Overall Length H	Journal Diameter OD <sup>3</sup>	Journal Length JL	Thread Length TL	Thread T	Shoulder Thickness S	Vee Height VH <sup>4</sup>	Hex Size HS	Nut & Washer N, W <sup>5,6</sup>
0	SWAC0X	W0X	-	18.8	4	9.9	6.1	M4 x 0.7	2.0	5.2	11	M4
0	SWAC0SSCR	W0SSCR	-									
0	SWAE0X	W0X	0.3									
0	SWAE0SSCR	W0SSCR	-									
1	SWAC1	W1	-	25.4	6	15.0	8.9	M6 x 1	2.1	6.0	12	M6
1	SWAC1X	W1X	-									
1	SWAC1SSX	W1SSX	-									
1	SWAC1SS227	W1SS227	-									
1	SWAE1	W1	0.4									
1	SWAE1X	W1X										
1	SWAE1SSX	W1SSX	-									
1	SWAE1SS227	W1SS227	-									
2	SWAC2	W2	-	39.1	10	24.9	15.0	M10 x 1.5	2.6	8.2	14	M10
2	SWAC2X	W2X	-									
2	SWAC2SSX	W2SSX	-									
2	SWAC2SS227	W2SS227	-									
2	SWAE2	W2	0.6									
2	SWAE2X	W2X										
2	SWAE2SSX	W2SSX										
2	SWAE2SS227	W2SS227										

**Notes:**

1. All dimensions are in mm.
2. Stud material is AISI 416 stainless steel.
3. It is recommended that holes to suit stud diameters are reamed to tolerance F6 for a sliding fit.
4. Vee Height (VH) Tolerance is ±0.05 mm.
5. Nuts are manufactured to DIN standard 934 (18-8 stainless steel).
6. Washers are manufactured to DIN standard 125 (18-8 stainless steel).
7. See guide wheel specifications for detailed data on wheels.
8. See load/life discussion in the technical reference section for sizing and selection information (page 15/16).

# Track: Sizes and Specifications

## Single Edge Track – Undrilled

- Easy installation/available from stock.
- Single edge design allows for flexible track pair spacing.
- Patented mounting shoulder allows for accurate positioning of Vee ways.
- Available “as formed,” or induction hardened and polished.
- Induction hardened track remains soft below the mounting shoulder, allowing for drilling or other machining.
- Available in either AISI 1045 carbon steel or 420 stainless steel.
- Available undrilled or pre-drilled for ease of installation.
- Can be easily butt-joined for stroke lengths exceeding maximum single piece lengths (6096mm). Maximum length available 6096mm (except T4SS maximum length 5790mm). Any length cut to a tolerance of  $\pm 1.5\text{mm}$ . (Cutting charge applies.)

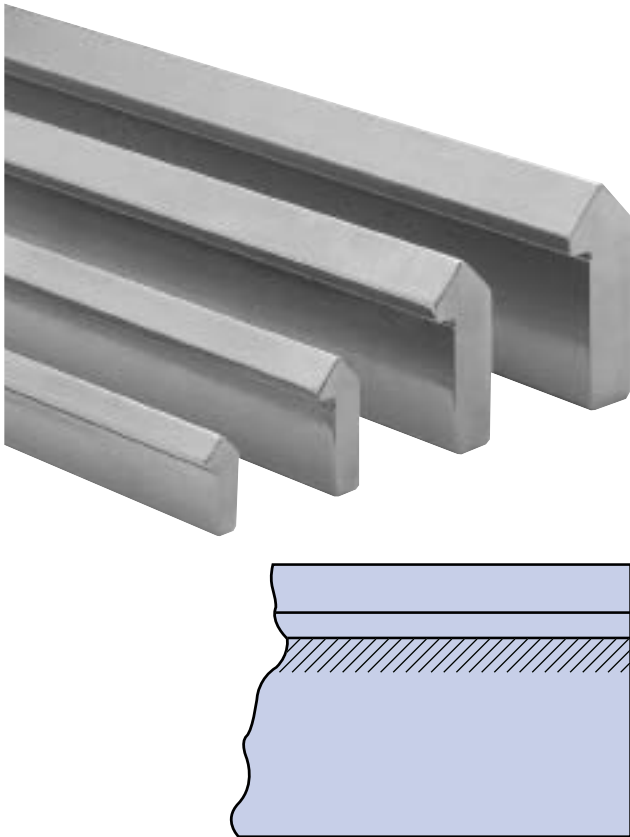

**To order:** Specify number of lengths, type of track, size, length.

**Example:** 5 ea., T4 1500mm (5 pieces, hardened track, size #4, 1.5m long).

**Notes:**

1. All dimensions are in mm.

**Specifications:**

- TS** Material AISI 1045 steel, cold formed to shape, unhardened, oiled.
- TS SS** Material AISI 420 series stainless steel, cold formed to shape, unhardened, oiled.
- T** Material AISI 1045 steel, top contact surfaces hardened 58 Rockwell C minimum, polished, oiled. Portion below indexing shoulder is left soft so it may be drilled for mounting.
- T SS** Material AISI 420 series stainless steel, top contact surfaces hardened 48 Rockwell C minimum, polished, oiled. Portion below indexing shoulder is left soft so it may be drilled for mounting.

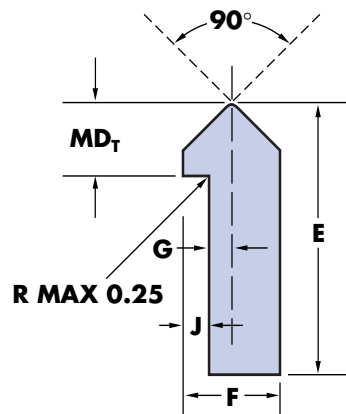

Size	E	F	G	J	MD <sub>r</sub>	Kg/m
1	11.09	4.74	0.78	1.57	3.17	0.272
2	15.87	6.35	0.78	2.36	4.75	0.509
3	22.22	8.71	1.57	2.76	6.35	1.02
4	26.97	11.09	2.36	3.17	7.92	1.63



## Single Edge Track - Drilled

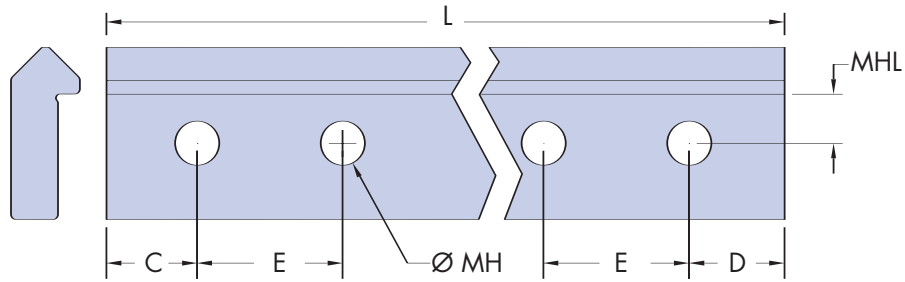

### To Order:

Specify number of lengths<sup>1</sup>, type of track, size, suffix D for drilled together with length required based on note 2<sup>3</sup>.

### Example:

4ea T3Dx1526 = T3 hardened track drilled x 1526mm long

Size	C	E	D	MH	MHL	L Max <sup>4</sup>
1	20.5	45	20.5	4.5	4	6026
2	43	90	43	6	5.6	6026
3	43	90	43	7	8	6026
4	43	90	43	9	9.5	6026

### Notes:

1. All dimensions are in mm.
2. Any length of track within L dimension can be supplied but for optimum price and delivery time drilled track lengths should be specified which maintain the C and D dimensions in the table above. In all cases C and D will be supplied equal.
3. Non-standard hole patterns can be accommodated upon request.
4. T4SS maximum length is 5790.

## Double Edge Track – Sizes and Specification

### Specifications

TDSO - Material AISI 1045 cold formed to shape, unhardened, oiled.

TDO - Material AISI 1045 vee contact surfaces hardened 58RC min polished, oiled.

Size	E	F	G	J	MDr	Kg/m
0	13.10	3.89	1.52	0.83	4.01	0.25

Maximum length<sup>1</sup> available 6096mm  
Any length cut to a tolerance of +/- 1.5mm  
(cutting charge applies)

#### To Order:

Specify number of lengths, type of track, size and length.

#### Example:

5ea TDOx1000 = 5 pieces double edge hardened track size TDO x 1000mm long.

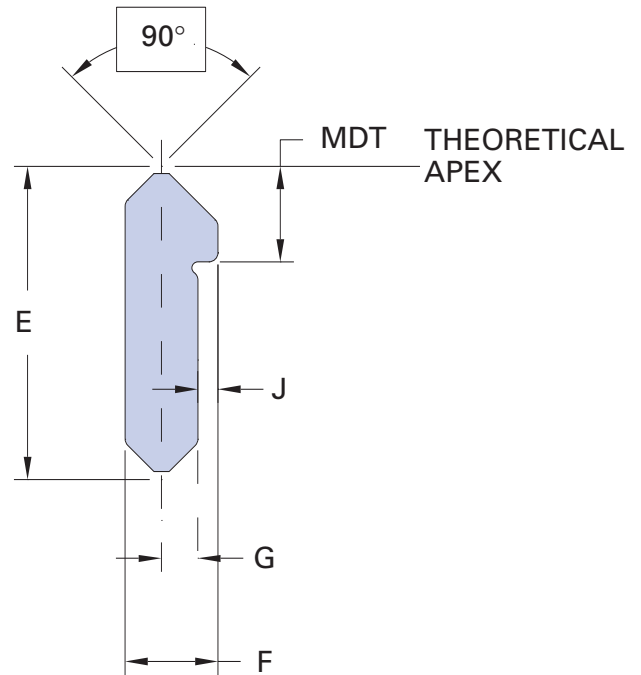

## Double Edge Track – Drilled

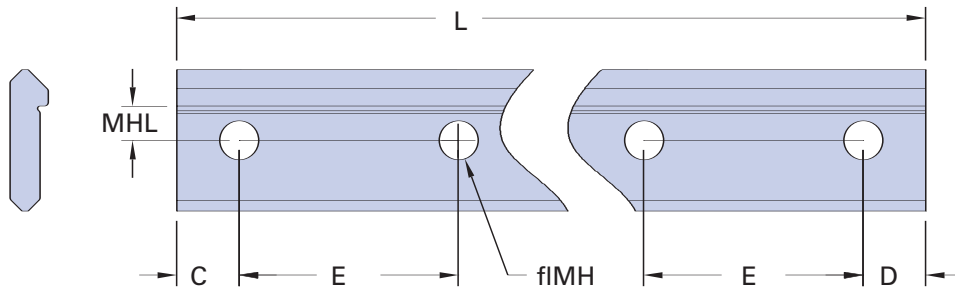

#### To Order:

Specify number of lengths, style of track, size, suffix D for drilled together with length required based on note 2<sup>3</sup>.

#### Example:

4ea TDODx4091 = 4 pieces double edge hardened track drilled TDO x 4091mm long.

Size	C	E	D	M <sub>H</sub>	M <sub>HL</sub>	L Max
0	20.5	45	20.5	3.5	2.54	6026

#### Notes:

1. All dimensions are in mm.
2. Any length of track within L dimension can be supplied but for optimum price and delivery time drilled track lengths should be specified which maintain the C and D dimensions in the table above. In all cases C and D will be supplied equal.
3. Non-standard hole patterns can be accommodated upon request.

## Support Bushings – Standard Profile

- Rigidly affixes guide wheels to a mounting surface precisely.
- Material options include 303 stainless steel or nickel plated carbon steel<sup>2</sup>.
- Concentric<sup>6</sup> and eccentric<sup>4</sup> configurations allow for system adjustment.
- Customer to supply screw/bolt to fix wheel bush assembly to mounting surface.
- Standard and low profile head height configurations are available to suit space requirements.

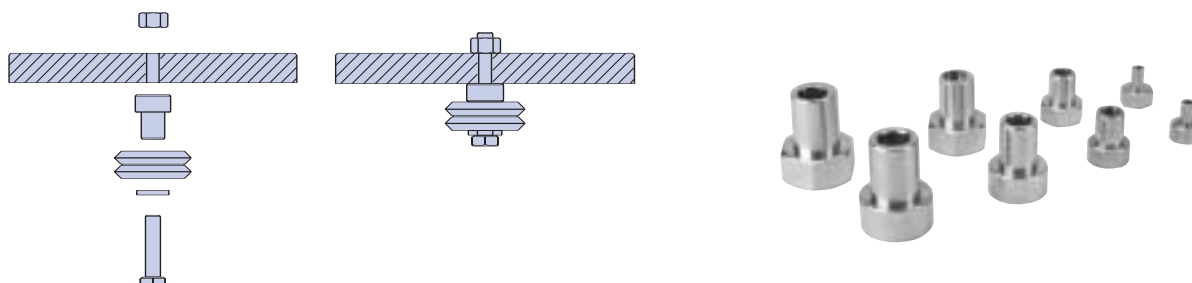

SUPPORT BUSHINGS STANDARD PROFILE DIMENSIONS <sup>1</sup>										
DualVee Size	Part Number	Recommended Fastener Size	Hex Size	Offset	Head Height	Length Body	Length Overall	Outside Diameter	Inside Diameter	Head Diameter
			HS	EC <sup>5</sup>	HH <sup>7</sup>	LB	LO	OD <sup>3</sup>	ID	HD
1	MB1	M4	-	-	6.22	7.6	13.8	4.76	4.01	11.2
1	MBX1	M4	12	0.18	6.22	7.6	13.8	4.76	4.01	-
2	MB2	M6	-	-	6.65	10.8	17.9	9.52	6.10	14.2
2	MBX2	M6	14	0.61	6.65	10.8	17.9	9.52	6.10	-
3	MB3	M8	-	-	9.47	15.6	25.1	11.99	8.10	19.1
3	MBX3	M8	19	1.07	9.47	15.6	25.1	11.99	8.10	-
4	MB4	M10	-	-	11.10	18.8	29.9	15.00	10.11	22.4
4	MBX4	M10	22	1.52	11.10	18.8	29.9	15.00	10.11	-
4XL	MB4XL	M14	-	-	14.35	25.1	39.5	21.97	14.10	31.8
4XL	MBX4XL	M14	30	1.52	14.35	25.1	39.5	21.97	14.10	-

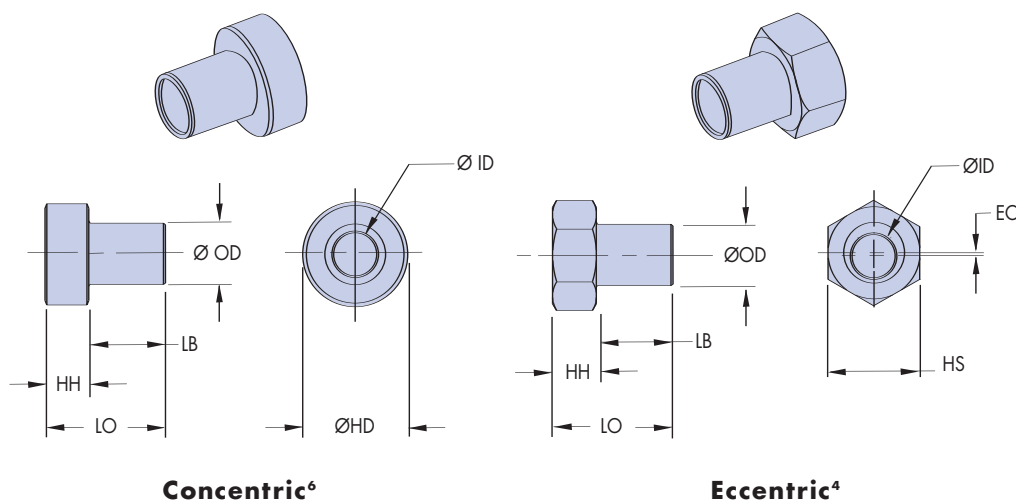

**Concentric<sup>6</sup>**

**Eccentric<sup>4</sup>**

### Notes:

1. All dimensions are in mm.
2. Standard materials are electroless nickel plated carbon steel or 303 stainless steel. Add "-SS" to the end of the part number for stainless steel.
3. The bushing's outside diameter is designed to fit the corresponding size DualVee guide wheel.
4. Part #MBX\_ indicates eccentric (adjustable) bushing; rotation of eccentric allows adjustment between track and guide wheels.
5. All mounting information within this catalogue assumes a central position of the eccentric bushing, thus allowing wheel position adjustment from "+EC" to "-EC".
6. Part #MB\_ indicates concentric (stationary) bushing; Since concentrically mounted wheels have a fixed position, these bushings set the alignment of the carriage assembly to the rail. Concentrically mounted wheels should be configured to carry the majority of the load whenever possible.
7. Head Height (HH) Tolerance is  $\pm 0.05\text{mm}$ .

# Support Bushings – Low Profile

## ■ Space saving<sup>2</sup>

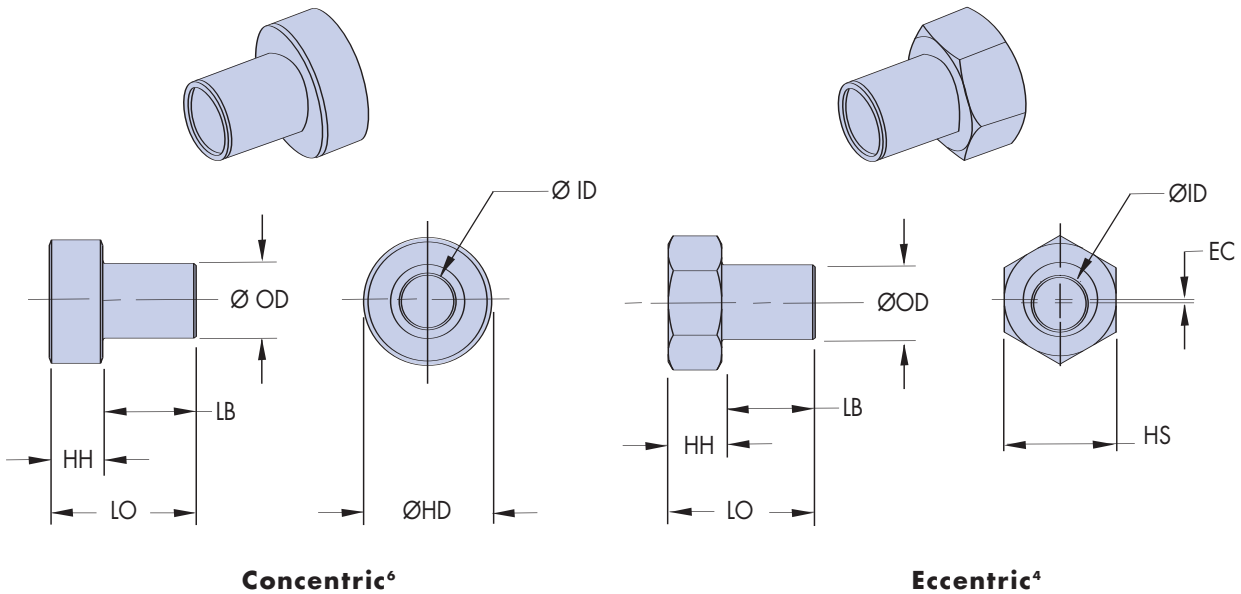

**Concentric<sup>6</sup>**

**Eccentric<sup>4</sup>**

SUPPORT BUSHINGS LOW PROFILE DIMENSIONS <sup>1</sup>										
DualVee Size	Part Number	Recommended Fastener Size	Hex Size HS	Offset <sup>5</sup> EC	Head Height HH <sup>7</sup>	Length Body LB	Length Overall LO	Outside Diameter OD <sup>3</sup>	Inside Diameter ID	Head Diameter HD
1	M1PWBC	M4	-	-	2.11	7.6	9.7	4.76	4.01	11.2
1	M1PWBX	M4	12	0.18	2.11	7.6	9.7	4.76	4.01	-
2	M2PWBC	M6	-	-	2.64	10.8	13.4	9.52	6.10	14.2
2	M2PWBX	M6	14	0.61	2.64	10.8	13.4	9.52	6.10	-
3	M3PWBC	M8	-	-	3.48	15.6	19.1	11.99	8.10	19.1
3	M3PWBX	M8	19	1.07	3.48	15.6	19.1	11.99	8.10	-
4	M4PWBC	M10	-	-	3.10	18.8	21.9	15.00	10.11	22.4
4	M4PWBX	M10	22	1.52	3.10	18.8	21.9	15.00	10.11	-
4XL	M4XLPWBC	M14	-	-	5.10	25.1	30.3	21.97	14.10	31.8
4XL	M4XLPWBX	M14	30	1.52	5.10	25.1	30.3	21.97	14.10	-

### Notes:

1. All dimensions are in mm.
2. Low profile support bushings are available in 303 stainless steel only.
3. The bushing's outside diameter is designed to fit the corresponding size DualVee guide wheel.
4. Part # M\_PWBX indicates eccentric (adjustable) bushing; rotation of eccentric allows adjustment between track and guide wheels.
5. All mounting information within this catalogue assumes a central position of the eccentric bushing, thus allowing wheel position adjustment from "+EC" to "-EC".
6. Part # M\_PWBC indicates concentric (stationary) bushing; Since concentrically mounted wheels have a fixed position, these bushings set the alignment of the carriage assembly to the rail. Concentrically mounted wheels should be configured to carry the majority of the load whenever possible.
7. Head Height (HH) Tolerance is  $\pm 0.05$ mm.

# Wheel Cover Assemblies

- Protects the wheel/track contact region<sup>4</sup>.
- Sweeps aside debris that may collect on the track.
- Continually dispenses a thin film of oil along the Vee way<sup>3</sup>.
- Lubricating properties increase load capacity and service life.
- Covers rolling element contact surface satisfying safety requirements<sup>2</sup>.

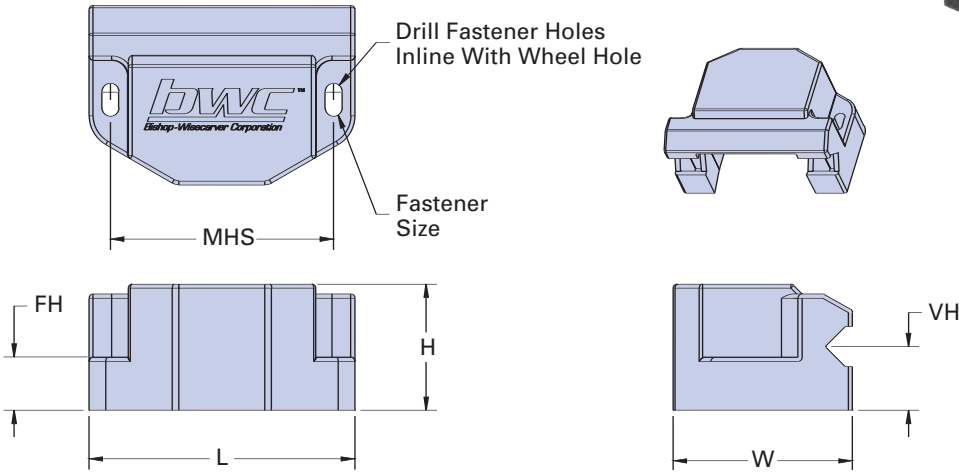
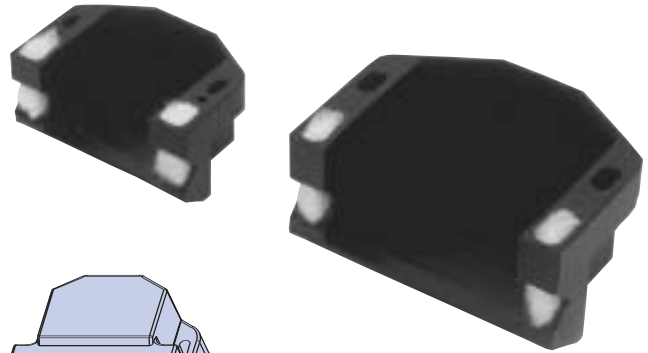

WHEEL COVER DIMENSIONS <sup>1</sup>									
Wheel Cover Profile	Size	Part Number	Length L	Mount Hole Spacing MHS	Height H	Fastener Height FH	Width W	Vee Height VH	Fastener Hole Size Metric
<b>Standard Height</b> (for use with standard height metric bushings)	1	WC1A	35.6	30.5	18.0	8.1	22.9	10.3	M2
	2	WC2A	50.8	42.7	24.1	10.1	34.3	12.2	M3
	3	WC3A	67.8	59.4	34.0	15.3	50.2	17.5	M3
	4	WC4A	88.9	78.0	40.1	19.3	63.5	20.7	M4
<b>Low Profile</b> (for use with low profile height metric bushings)	1	WC1LPA	35.6	30.5	14.0	4.1	22.9	6.3	M2
	2	WC2LPA	50.8	42.7	19.6	5.6	34.3	7.7	M3
	3	WC3LPA	67.8	59.4	28.0	9.3	50.2	11.5	M3
	4	WC4LPA	88.9	78.0	32.1	11.3	63.5	12.6	M4

WHEEL COVER ASSEMBLIES - HARDWARE				
Wheel Cover Profile	DualVee Size	Assembly Part Number	Washer W <sup>3</sup>	Fastener S <sup>3</sup>
<b>Standard Height</b>	1	WC1A	M2	M2 x .4 x 12
	2	WC2A	M3	M3 x .5 x 16
	3	WC3A	M3	M3 x .5 x 20
	4	WC4A	M4	M4 x .7 x 25
<b>Low Profile</b>	1	WC1LPA	M2	M2 x .4 x 8
	2	WC2LPA	M3	M3 x .5 x 12
	3	WC3LPA	M3	M3 x .5 x 16
	4	WC4LPA	M4	M4 x .7 x 20

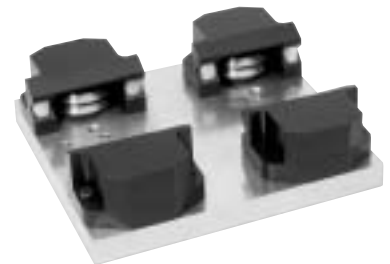
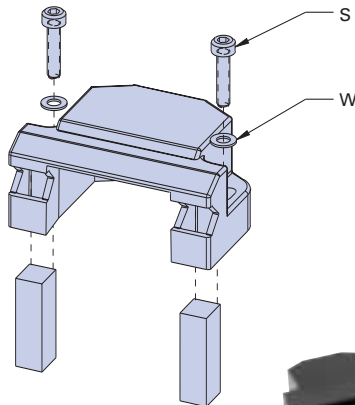

### Notes:

1. All dimensions in mm.
2. Wheel cover material is ABS black.
3. Felt material is white, pure wool, per specification SAE F-10 or ASTM 9R1.
4. Wheel covers are supplied complete with socket head cap screws and washers (stainless steel).

# Lubricator Assemblies

- Easy to install/available from stock<sup>4</sup>.
- Dispenses a thin film of oil along the Vee way<sup>3</sup>.
- Lubricating properties increases load capacity and service life.
- Stainless steel lubricator housing<sup>2</sup>.

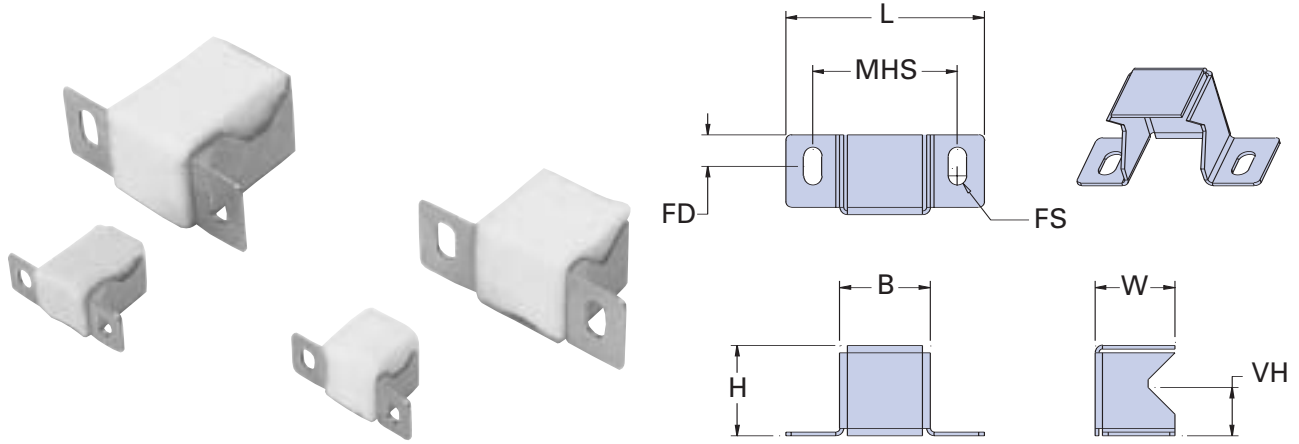

LUBRICATOR DIMENSIONS <sup>1</sup>										
Lubricator Profile	Dual Vee Size	Part Number	Overall Length L	Hole Spacing MHS	Body Length B	Height H	Width W	Vee Height VH	Fastener Hole Location FD	Fastener Hole Size Diameter FS
<b>Standard Height</b> (for use with standard height metric bushings)	1 & 2	TL12A	28.0	20.0	12.0	17.5	11.4	11.0	4.6	3.0
	3 & 4	TL34A	46.7	34.0	21.3	30.5	18.8	19.1	7.4	4.3
<b>Low Profile</b> (for use with low profile height metric bushings)	1 & 2	TL12LPA	28.0	20.0	12.0	13.5	11.4	7.1	4.6	3.0
	3 & 4	TL34LPA	46.7	34.0	21.3	21.3	18.8	12.3	7.4	4.3

LUBRICATOR ASSEMBLIES - HARDWARE			
Lubricator Profile	Part Number	Washer W <sup>3</sup>	Fastener S <sup>3</sup>
<b>Standard</b>	TL12A	M2	M3 x .5 x 6
<b>Height</b>	TL34A	M3	M4 x .7 x 8
<b>Low Profile</b>	TL12LPA	M2	M3 x .5 x 6
<b>Profile</b>	TL34LPA	M3	M4 x .7 x 8

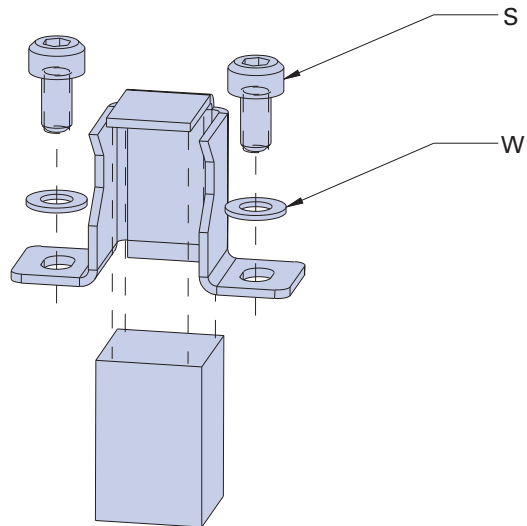

### Notes:

1. All dimensions in mm.
2. Lubricator housing material per specification ANSI 303, 304, or 316 stainless steel.
3. Felt material is white, pure wool, per specification SAE F-10 or ASTM 9R1.
4. Lubricators are supplied complete with socket head cap screws and washers (stainless steel).

# Mounting Dimensions

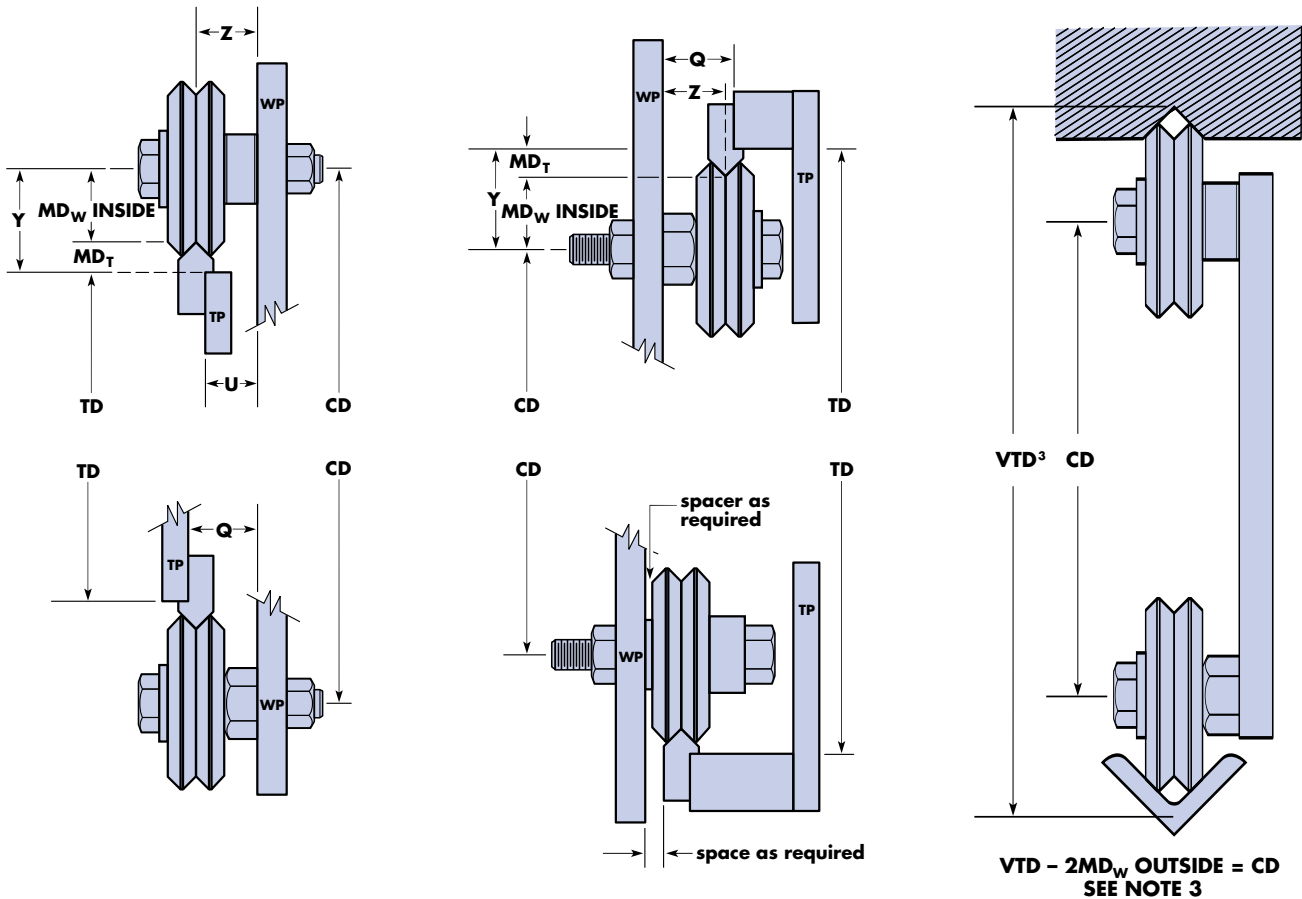

outboard mounting formula  $TD + 2 Y = CD$

inboard mounting formula  $TD - 2 Y = CD$

Where  $CD$  is less than wheel diameter, Guide Wheels must be offset for proper clearance.

## Legend

$MD_w$ outside = Mounting distance, wheel, using outside Vee (page 4)	$WP$ = Wheel plate <sup>2</sup>
$MD_w$ inside = Mounting distance, wheel, using inside Vee (page 4)	$TP$ = Track plate
$MD_t$ = Mounting distance, track (page 7)	$Z$ = Distance from WP to centre of wheel
$TD$ = Track distance	$Q$ = $Z + G$
$CD$ = Centre distance <sup>4</sup>	$U$ = $Z - G$
$Y$ = $MD_t + MD_w$ inside	$G$ = Distance from TP to centre line of track

## Dimensions<sup>5</sup> standard profile bushes

Size	Z	Q	U	Y
0	n/a	n/a	n/a	9.95
1	10.16	10.94	9.38	11.12
2	12.22	13	11.44	17.45
3	17.41	18.98	15.84	25.4
4	20.63	22.99	18.27	33.32
4XL <sup>1</sup>	27.05	29.41	24.69	39.67

## Dimensions<sup>5</sup> low profile bushes

Size	Z	Q	U	Y
0	n/a	n/a	n/a	9.95
1	6.05	6.83	5.27	11.12
2	8.21	8.99	7.43	17.45
3	11.42	12.99	9.85	25.4
4	12.63	14.99	10.27	33.32
4XL <sup>1</sup>	17.8	20.16	15.44	39.67

## Notes:

1. Data left uses the same size DualVee track and wheel except 4XL which uses W4XXL guide wheel with size T4 track.
2. It is recommended that wheel plates be constructed with concentric bushes on one side and eccentric on the other.
3.  $VTD$  dimension is the theoretical intersection of the 90° angle.
4.  $CD$  for double edge track size 0 and size 0 wheels = 24.98.
5. All dimensions are in mm.

# DualVee – Overview

## Load/Life Relationship

Several factors influence the service life of a DualVee linear system. Through research and development a simple method has been devised to estimate the load/life relationship for a specific DualVee guide mechanism under defined loading conditions. The methodology accounts for the size of the DualVee bearing elements, relative spacing, and the orientation, location, and magnitude of the load. The curve is based upon clean, well lubricated track conditions, so for applications where lubrication is prohibited, a derating factor must be applied.

It is important to note that secondary considerations such as maximum velocity, acceleration rates, duty cycle, stroke length, environmental conditions, the presence of shock and vibration, and extreme temperature ranges can all impact service life to varying degrees. As such, the sizing method outlined below should be used conservatively, and considered only as a guideline for the sizing of DualVee components and assemblies. When time and budget permits, the prototyping of a DualVee arrangement is recommended to confirm service life expectations.

### The Load/Life Equation — Sizing and Selection

The life of a DualVee guide will be limited to the life of the most heavily loaded bearing in the design.

Step 1: Calculate the resultant radial and axial loads reflected to each bearing element in the linear guide design.

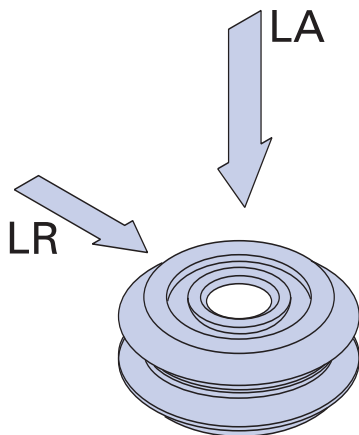

If assistance is required in resolving specific loads into the resultant reaction forces at the guide wheel interface, contact our applications engineering staff for support. It is recommended that the Application Data Sheet on page 19 be submitted beforehand, with as much application information detailed as possible.

Step 2: Calculate the load factor for the most heavily loaded bearing.

$$LF = LA / LA_{max} + LR / LR_{max}$$

Where LF = Load Factor

LA = Resultant axial load on the guide wheel  
LA<sub>max</sub> = The maximum axial working load

capacity of the guide wheel

LR = Resultant radial load on the guide wheel

LR<sub>max</sub> = The maximum radial working load

capacity of the guide wheel

■ Bearings should be sized such that  $L_f \leq 1$

■ The most heavily loaded bearing will have the highest load factor

Due to varying application load and speed parameters and environmental conditions, the appropriate adjustment factor must be applied to the maximum axial and radial working load capacities (LA<sub>max</sub> and LR<sub>max</sub>) as follows:

Adjustment Factor	Application Conditions
1.0-0.7	clean, low speed, low shock, low duty.
0.7-0.4	moderate contaminants, medium duty, medium shock, low to medium vibration, moderate speed.
0.4-0.1	heavy contamination, high acceleration, high speed, medium to high shock, high vibration, high duty cycle, dry running.

Oscillating motion resulting in less than one full revolution of the wheel under load can cause accelerated wear on the internal bearing elements. Testing of such systems is recommended to verify compatibility of the design with load/life requirements.

In lightly loaded applications bearing preload can be higher than the working load. A figure equivalent to 3% of the radial working load capacity should therefore be included in the LR figure when calculating life.



# DualVee – Overview

## DualVee Guide Wheel Load Capacities

LOAD CAPACITY (N)						
Part Number	Radial Working Load Capacity LRmax (N) <sup>2</sup>	Axial Working Load Capacity LAmax (N) <sup>2</sup>	BDLR <sup>1</sup> Radial (N)	BSLR <sup>1</sup> Radial (N)	BDLR <sup>1</sup> Axial (N)	BSLR <sup>1</sup> Axial (N)
W1	595	252	2180	1110	1090	1040
W2	1431	625	4700	2780	2380	2630
W3	3074	1701	9150	5050	4500	4800
W4	4704	4001	12800	7900	6350	7450
W0X	265	123	1050	500	530	470
W1X	595	252	2180	1110	1090	1040
W2X	1431	625	4700	2780	2380	2630
W3X	3074	1701	9150	5050	4500	4800
W4X	4704	4001	12800	7900	6350	7450
W4XXL	7571	6552	20600	14300	10400	13500
W1SSX	595	252	2180	1110	1090	1040
W2SSX	1431	625	4700	2780	2380	2630
W3SSX	3074	1701	9150	5050	4500	4800
W4SSX	4704	4001	12800	7900	6350	7450
W4SSXXL	7571	6552	20600	14300	10400	13500
W0SSCR	220	102	872	415	440	390
W1SS227	494	208	1810	920	900	870
W2SS227	1188	520	3900	2310	1980	2180
W3SS227	2554	1399	7600	4200	3700	4000
W4SSCR	3896	3320	10600	6560	5270	6180

Step 3: Apply the load factor to the load/life equation below:

$$\text{Life (in Km)} = \text{LC} / (\text{LF})^3$$

Where LF = Load Factor

LC = Life Constant

Life constants are provided as tabulated below.

LOAD/LIFE CONSTANTS	
DualVee Size	LC
0	41
1	55
2	87
3	130
4	171
4XL	215

### Notes:

1. The BDLR (Basic Dynamic Load Rating) and BSLR (Basic Static Load Rating) are according to AFBMA STD 9-1990. These ratings are based on industry standard bearing calculations and are for comparison to other products as measured against the same standard. Working load capacities should be used for component sizing and selection.
2. Sizing and selection should be based on working load capacity ratings according to the sizing guidelines presented in the technical reference section (see load/life relationship, pages 15/16). Working load capacities reflect lubricated wheel/track interface.

## DualVee – Overview

### Lubrication

Lubrication is the key to maximising the life of a DualVee linear guide. Internally, DualVee guide wheels are lubricated for life with an extreme pressure, corrosion resistant grease. However, lubrication of the wheel/track interface is the responsibility of the user. A light machine oil or an extreme pressure grease will serve well in minimising wear, stick slip, and corrosion on the guide ways in a DualVee-based design. Lubrication will maximise the load capacity of an individual bearing element. As such, for any specific application loading condition, the presence of lubrication on the guide ways will significantly increase the service life over a non-lubricated configuration under the same loads.

Lubrication will also increase the maximum linear velocity that a DualVee bearing arrangement can endure. In applications where high speed or high acceleration rates are present, lubrication of the wheel/track interface is highly recommended. Lastly, lubrication will reduce the overall coefficient of friction of the guide, which, depending on the level of preload, can fall anywhere from 0.008 to 0.015. The availability of lubricators and wheel covers gives design engineers an opportunity to design lubrication right into the DualVee mechanism with little effort. See specifications on wheel covers and lubricators for more detail.

### Track Butting Considerations

Precut lengths of track are not suitable for butting end to end. Please contact the factory when track lengths longer than the maximum available single piece lengths are required, so that the ends can be specially prepared. When constructing track systems longer than 6 metres, the joints on parallel tracks should be staggered for greater accuracy and smoothness.

### Track Hardening

For most applications, and to ensure greater resistance to wear, the 'T' series hard edge track should be used. The lower cost 'TS' soft track is suitable only for light duty, light load applications.

### Contamination/Wear Resistance

Since the circumference of the wheel is greater at the major diameter than at the minor diameter, there is a constant wiping action on the track producing a self cleaning effect. As such, DualVee guide wheels are employed in a wide variety of harsh environments, including the presence of metal chips, powders, fibres, slurries, etc. It is important to note that such environments will often limit the service life of a DualVee linear guide to some extent. Since environments vary from application to application, it is recommended that DualVee systems be prototyped before employing on a large scale. As an example, an OEM who is building a paper processing machine may want to prototype a linear guide in application where the guide ways are exposed to unique combinations of chemicals and paper fibres. It's difficult to predict exactly how the materials will behave in many cases. For instance a fine, yet hard powder material may accelerate wear in one case but simply be swept aside in another, depending on parameters such as particle size, temperature, humidity, and lubrication. Regardless, DualVee is clearly the choice of antifriction linear guide technology in difficult environments, particularly when success is mandatory and reliability is critical.

The other main factor affecting wear resistance is lubrication. Wheel covers or lubricators should be designed in whenever possible. Both will distribute a thin coating of oil lubricant along the contact surface of the DualVee track. The wheel covers offer added protection by preventing debris from entering the wheel/track contact surface. Lubricated and relatively clean wheel/track contact surfaces will ensure maximum service life in a DualVee linear guide.

## DualVee - Overview

### System Adjustment

The stationary bushings determine the alignment of the system. They should carry the major load whenever possible. It is also good practice to configure the wheels so that the load is predominantly radial.

Normal adjustment is obtained by rotating the eccentric bushings until all free play is removed from the carriage assembly. When the eccentrics are adjusted and the carriage plate is held firmly in place, it should be possible to rotate, by hand, any of the four guide wheels in the system against its mating track. If rotation is not possible, preload on the wheels should be reduced accordingly. Overtightening of the eccentric adjustment could result in premature bearing failure. Such a condition can exert a force greater than the load rating of the wheel.

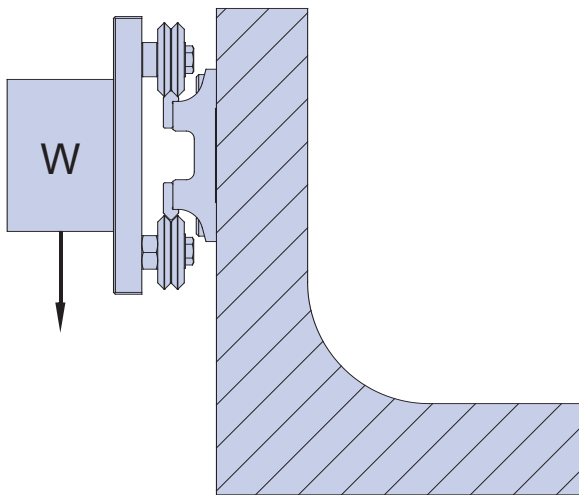

**Figure 9:** Linear guide configured primarily radial load.

### Wash Down Environments

For wash down applications, pillars can be used to mount track to a mounting surface, eliminating dirt traps, and allowing for washdown (see sketch below).

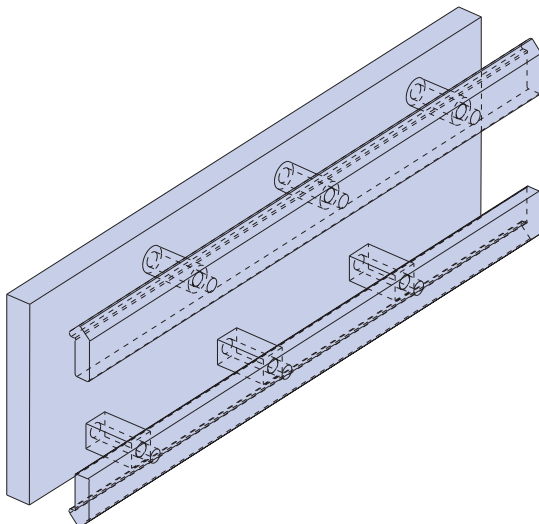

**Figure 10:** DualVee track mounted with pillars eliminates dirt traps.

### Clean Room Products

Clean room compatible guide wheels are manufactured from 440C stainless steel bearing elements, and contain stainless steel retainers and shields. They are internally lubricated with synthetic, corrosion resistant, clean room-compatible grease.

For clean room operation, it is often desirable to plate the track with thin dense chrome (TDC), black oxide, or electroless nickel. Stainless steel track can also be specially cleaned prior to heat treat and then passivated. Contact Hepco applications engineering for assistance with your clean room linear guidance questions. Higher level assemblies, custom engineered to accommodate specific clean room requirements, can be furnished by Hepco. Contact Hepco Application Engineers for particle emissions data.

### High Temperature Products

All Hepco high temperature guide wheel products are manufactured from specially processed, thermally stabilised, 440C stainless steel. Lubricated with a specially formulated synthetic grease, these guide wheels are capable of operating in temperatures up to 260°C. Special consideration should be given to guide wheel-based designs when operating above temperatures of 150°C. Designers must make sure that a suitable lubricant is used on the wheel track interface, and if lubrication is prohibited, the appropriate derating of the bearing should be factored in.





## Full Size Drawings

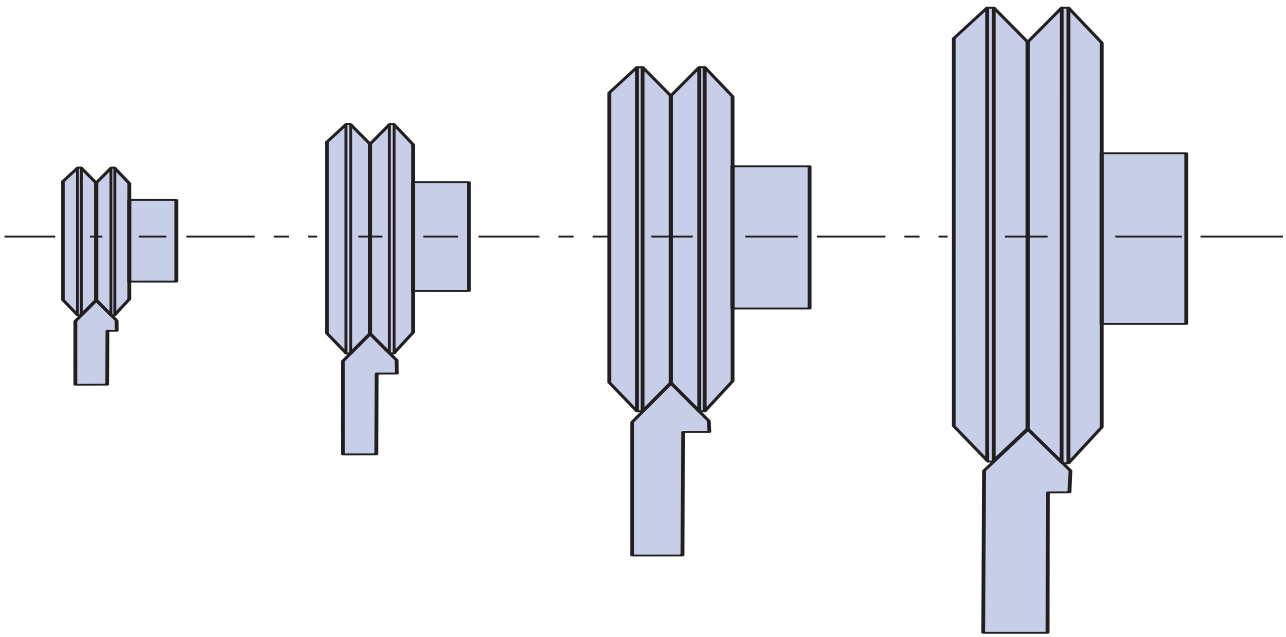

**Full Scale**

Selection of the appropriate size wheel/track for a given application is often made initially by reference to the physical size of the product as opposed to load capacity.

These full size sections will help with the selection process prior to checking the load/life which can be checked on pages 15/16.

# HepcoMotion® Product Range



# BishopWisecarver Product Range

HepcoMotion® – Exclusive European partners and distributors for Bishop-Wisecarver since 1984.



For further information on HepcoMotion® products – please request our leaflet 'FPL'



## HepcoMotion®

Lower Moor Business Park, Tiverton Way, Tiverton, Devon, England EX16 6TG  
Tel: +44 (0)1884 257000 Fax: +44 (0)1884 243500  
[sales@hepcotion.com](mailto:sales@hepcotion.com)

CATALOGUE No. DV 06 UK © 2004 Hepco Slide Systems Ltd.

Reproduction in whole or part without prior authorisation from Hepco is prohibited. Although every effort has been made to ensure the accuracy of the information in this catalogue, Hepco cannot accept liability for any omissions or errors. Hepco reserves the right to make alterations to the product resulting from technical developments.

Many Hepco products are protected by: Patents, Copyright, Design Right or Registered Design. Infringement is strictly prohibited and may be challenged in law. The Customer's attention is drawn to the following clause in Hepco's conditions of sale:

'It shall be the Customer's sole responsibility to ensure that goods supplied by Hepco will be suitable or fit for any particular application or purpose of the Customer, whether or not such application or purpose is known to Hepco. The Customer will be solely responsible for any errors in, or omissions from, any specifications or information the Customer provides. Hepco will not be obliged to verify whether any such specifications or information are correct or sufficient for any application or purpose.'

Hepco's full conditions of sale are available on request and will apply to all quotations and contracts for the supply of items detailed in this catalogue.

HepcoMotion is the trading name of Hepco Slide Systems Ltd.



INVESTOR IN PEOPLE

