

# Machine & Inspection Light

## Adj arm 2D fluorescent task light 16w

A general purpose –designed robust durable industrial task light providing a long trouble free life in demanding conditions.

### Features:

- High quality friction arm joints, move easily, yet retain position, tested to over 30,000 movements
- Vibration resistant mountings, arms and lampholders for demanding operating conditions
- Versatile and flexible positioning, relative to subject, based on variety of arm length combinations
- Spun aluminium shade is design maximises the light output from lamp
- Flexible visor to minimise glare
- Prismatic shield for even light distribution
- Cable is totally enclosed within the unit
- Metal parts are coated in tough chip resistant epoxy polyester powder paint
- Switch is located on ballast housing for ease of use
- Head is moulded from strong shock resistant thermoplastic material which acts as an electrical insulator
- Moulded ballast housing

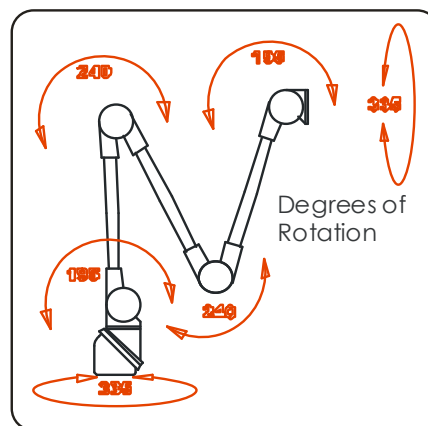
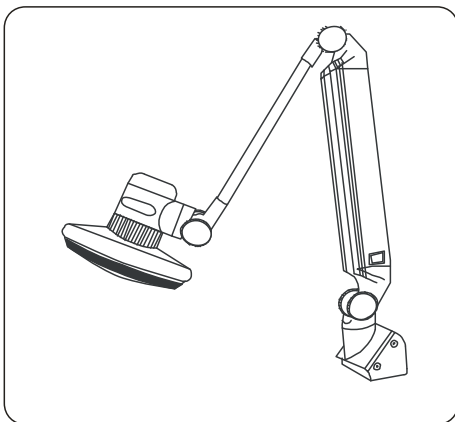

Primary Voltage:	230/240v ac
Ballast Type:	Electronic high Frequency 230/240v 50/60 Hz
Lamp Type:	2D 4 pin
Max Wattage:	16 and 28watt
Lamp Base:	Lampholder 2D panel mounting
Switch Fitted:	Yes on ballast housing
IP Rating:	IP 20 (can be made to IP64 rating)
Base Type:	Universal Base – can be horizontal or vertical mounted
Arms:	2 400mm + 400mm
Shade:	16w = 178mm 28w = 271mm spun aluminium
Shield Fitted:	Yes (prismatic for even light distribution)
Visor:	Flexible moulded Visor
Trailing Cable:	Not fitted (available as accessory c/w 20mm cable gland)
Manufacturing Standard:	BS EN 60598
RHOS Compliant:	Yes
WEE Compliant:	Yes
Finish & Colour:	Powder coated Gunmetal Grey

**Accessories:**

**Lamps**

2D CFL  
Square 4 pin  
16 watt & 28 watt



**Clamps & cable assemblies**

UK 3 pin plug



Clamp 744-003



Euro Plug



**Universal Base Mounting**

