

# Series AC Spacers and Brackets Accessories

## Spacer (X)

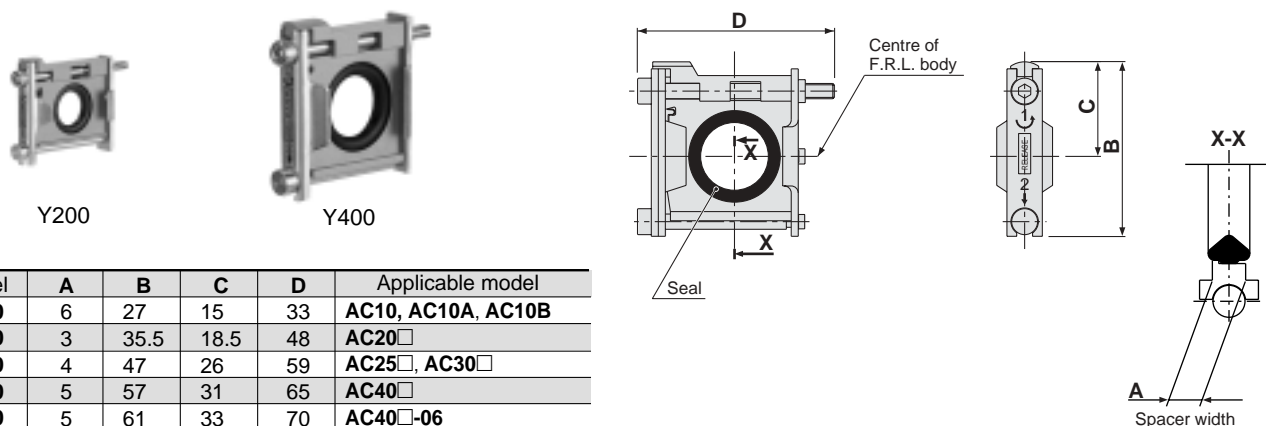

Model	A	B	C	D	Applicable model
Y100	6	27	15	33	AC10, AC10A, AC10B
Y200	3	35.5	18.5	48	AC20□
Y300	4	47	26	59	AC25□, AC30□
Y400	5	57	31	65	AC40□
Y500	5	61	33	70	AC40□-06
Y600	6	75.5	41	86	AC50, AC55, AC60 AC50B, AC55B, AC60B

### Replacement parts

Description	Material	Part no.					
		Y100	Y200	Y300	Y400	Y500	Y600
Seal	HNBR <sup>Note 2)</sup>	Y100P-060AS <sup>Note 1)</sup>	Y200P-060S	Y300P-060S	Y400P-060S	Y500P-060S	Y600P-060S

Note 1) Y-100 comes with 2 O-rings.

Note 2) NBR seal is used for Y100 spacer because of no direct contact with fluid.

## Spacer with Bracket (Z)

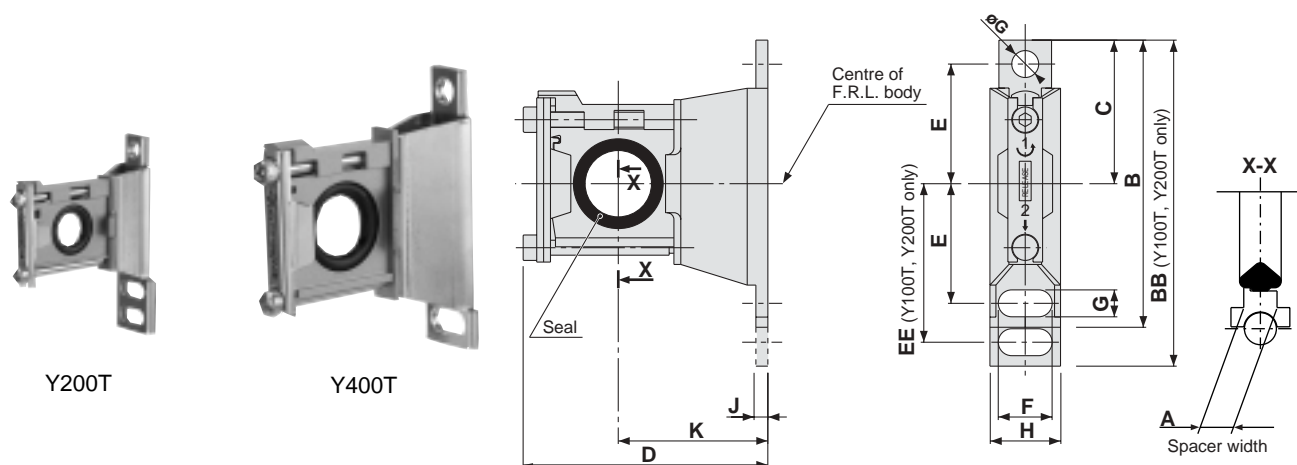

Model	A	B	BB	C	D	E	EE	F	G	øG	H	J	K	Applicable model
Y100T	6	—	56	24.5	40.5	20	27	6.8	4.5	4.5	14	2.8	25	AC10□
Y200T	3	—	67	29	53	24	33	12	5.5	5.5	19	3.2	30	AC20□
Y300T	4	82	—	41	68	35	—	14	7	7	21	4	41	AC25□, AC30□
Y400T	5	96	—	48	81.5	40	—	18	9	9	26	4	50	AC40□
Y500T	5	96	—	48	86	40	—	18	9	9	27	4.6	50	AC40□-06
Y600T	6	120	—	60	112	50	—	20	11	11	31	6.4	70	AC50, AC55, AC60, AC50B, AC55B, AC60B

### Replacement parts

Description	Material	Part no.					
		Y100T	Y200T	Y300T	Y400T	Y500T	Y600T
Seal	HNBR <sup>Note 2)</sup>	Y100P-060AS <sup>Note 1)</sup>	Y200P-060S	Y300P-060S	Y400P-060S	Y500P-060S	Y600P-060S

Note 1) Y-100T comes with 2 O-rings.

Note 2) NBR seal is used for Y100T spacer because of no direct contact with fluid.