

LOC	DIST	REVISIONS					
AF	50	P	LTR	DESCRIPTION	DATE	DWN	APVD
			Y1	REVISED PER ECO-11-004820	11MAR11	RK	HMR

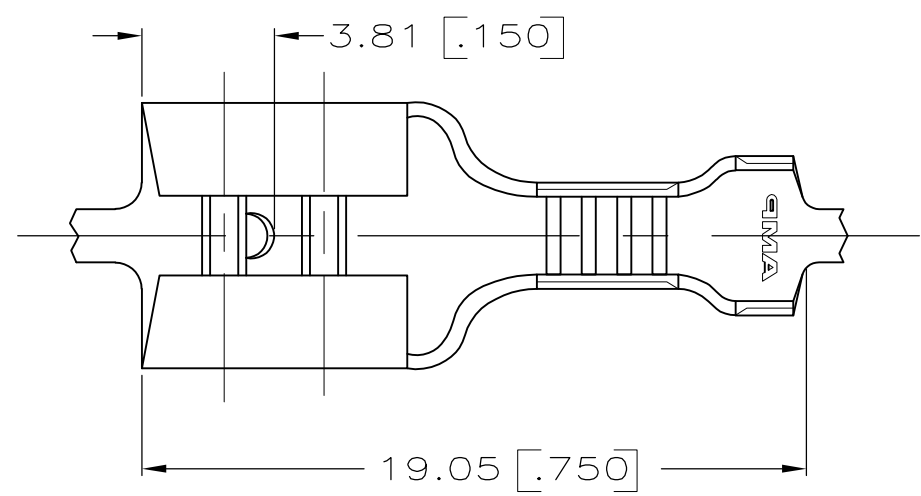

1.52 [.060]
1.27 [.050]

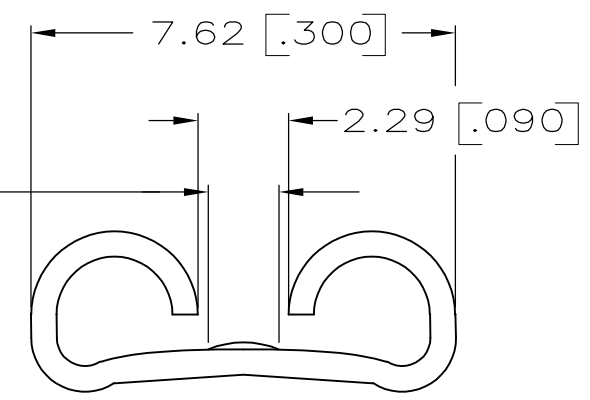

VIEW A-A
SCALE 8:1

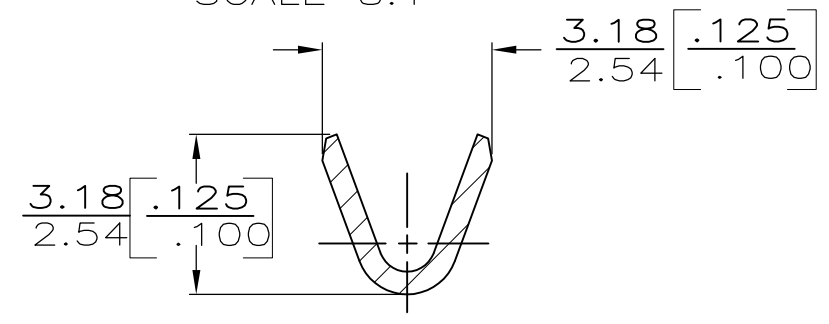
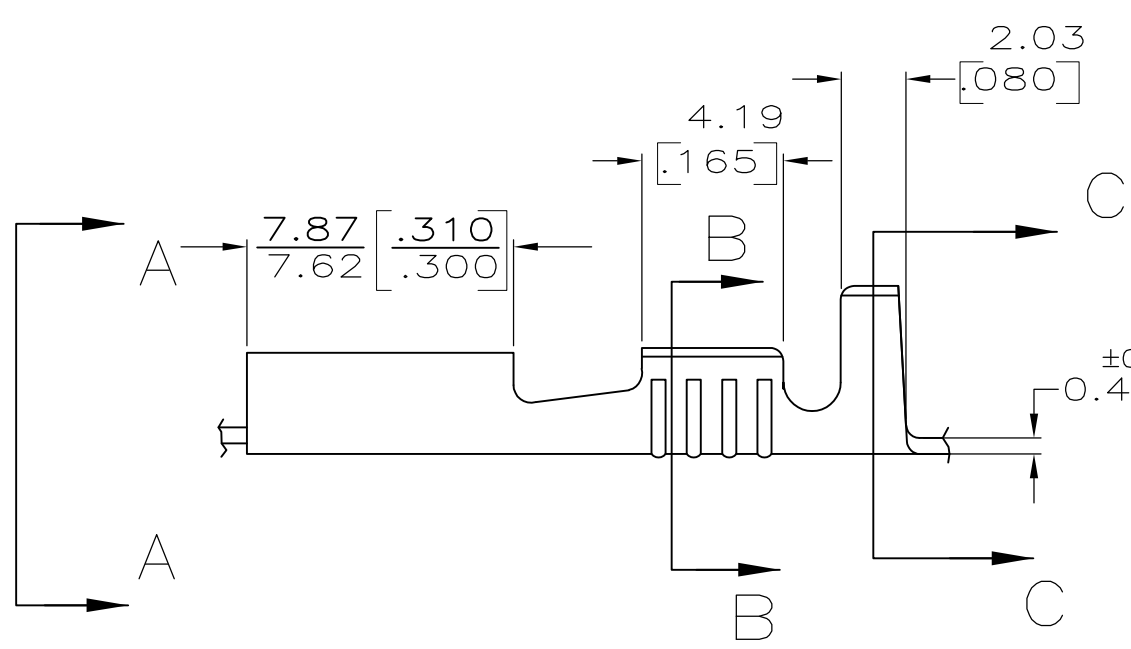

SECTION B-B
SCALE 8:1

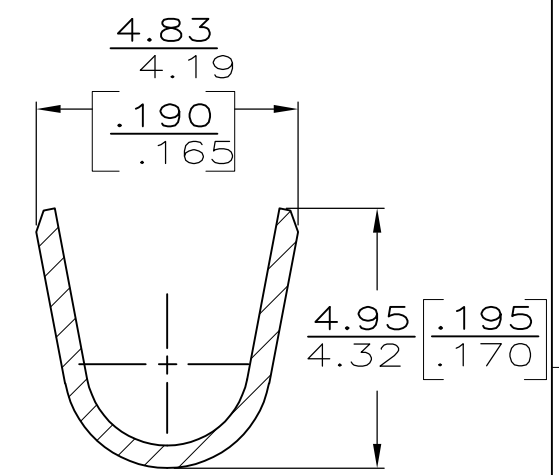

SECTION C-C
SCALE 8:1

- 1 DIMENSIONS IN BRACKETS ARE IN INCHES
- 2 CONTINUOUS STRIP ON REELS
- 3 FOREIGN PRODUCTION ONLY
- 4 FOREIGN PRODUCTION ONLY, INTERLEAVING PAPER REQUIRED
- 5 REELED UPSIDE DOWN WITH INTERLEAVING PAPER.
- 6 PRELIMINARY - NOT FOR PRODUCTION
- 7 FOR AMP ITALY ONLY, NOT STRESS RELIEVED.

2.29-3.30 [.090-.130]	0.3-0.8mm ² [22-18]	±0.025 ±.001 0.81 [.032]	△ 1-41772-1 △ 41772-4 △ 41772-3 △ 41772-1 41772
INSUL RANGE	WIRE SIZE	MATING TAB THK	PART NO

THIS DRAWING IS A CONTROLLED DOCUMENT.		DWN JR RUTH 4/26/89	TE Connectivity			
DIMENSIONS: mm[INCHES]		CHK MS FEHER 4/26/89				
TOLERANCES UNLESS OTHERWISE SPECIFIED:		APVD C MEYERS 4/26/89	NAME RECEPTACLE, FASTON™ .250 SERIES			
0 PLC ± - 1 PLC ± - 2 PLC ± - 3 PLC ± 0.25 [.010] 4 PLC ± - ANGLES ± -		PRODUCT SPEC -				
MATERIAL H04 BRASS	FINISH TIN 0.002032 [.000080] MIN	APPLICATION SPEC 114-2036	SIZE A3	CAGE CODE 00779	DRAWING NO C-41772	RESTRICTED TO -
CUSTOMER DRAWING			SCALE 5:1	SHEET 1 of 1	REV Y1	