

69176-008LF - Mini-PV™, Basics+ : 2.54 x 2.54 mm (0.1 x 0.1 in.) Centerline Crimp-to-Wire PV Receptacle Housing, Double Row, Polarized

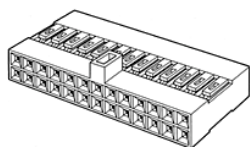

www.fci.com



Mating Half

- ▶ 69168-108HLF
- ▶ 78207-108HLF
- ▶ 67996-108HLF
- ▶ 68020-108HLF

Specifications

General	
Number of contacts	8
Number of rows	2
Orientation	Vertical
Product Type	Crimp-to-Wire Housing
Polarization (Key)	Yes
Mating half	Mates with 0.64 mm (0.025 in.) Square Pin with Length of 5.33 mm (0.21 in.) min. to 6.1 mm (0.24 in.) max.
Series Number	69176
Dimensional	
Length (Mating pin)	5.33 mm (0.21 in.) to 6.1 mm (0.24 in)
Size (Wire)	22 to 36 AWG
Electrical	
Resistance (Insulation)	100000 M-ohms
Voltage rating	1000V rms
Physical	
Color (Housing)	Black
Material (Housing)	PPE+PS
Temperature (Operating - range)	-40°C to +105°C
Approvals / Certifications	
UL File Number	E66906
CSA File Number	LR46923
Approvals / Certifications	UL and CSA Approved

Other Features Accessory	Polarization Plug 65307-001LF
Packaging (Type)	Bag
Comments	PV™ Contact Removal Tool: Part Number HT-0080

PRODUCT NUMBER
SEE TABLE

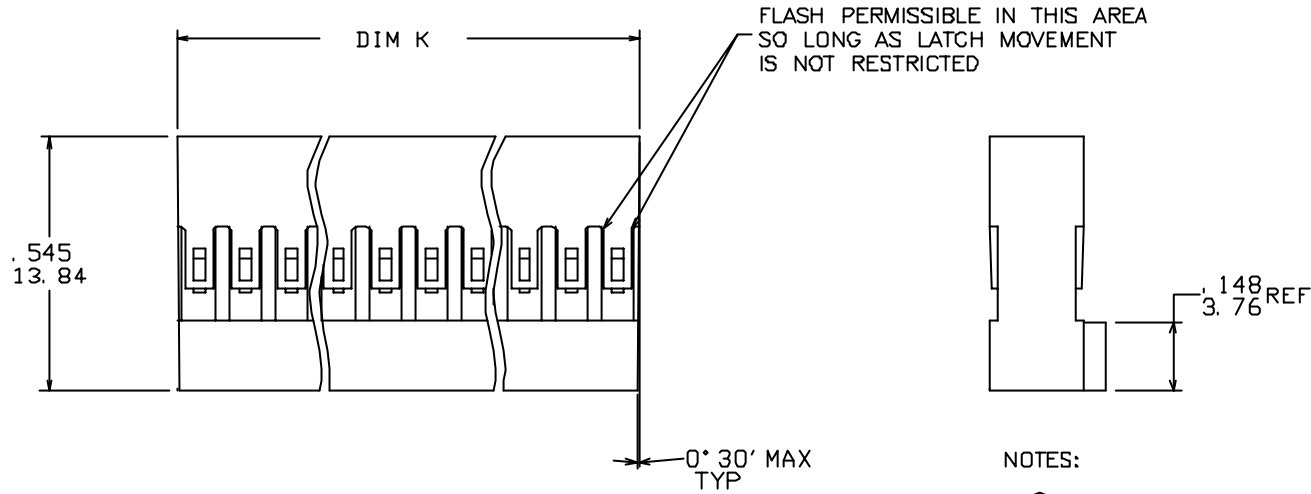

NOTES:

- ① PIN LENGTH RECOMMENDED IS $.225 \pm .015 / 5.72 \pm 0.38$.
- ② MOLDING MATERIAL: MODIFIED POLYPHENYLENE ETHER, FLAME RETARDANT PER UL-94V-0, COLOR: BLACK.
3. SEE TA-75 FOR CRIMPING INSTRUCTIONS.
PRODUCT SPECIFICATION: BUS-12-067.
- ④ .003/0.08 MAX FLASH PERMISSIBLE AROUND LEAD IN.
5. PRODUCT MEETS EUROPEAN UNION DIRECTIVES AND OTHER COUNTRY REGULATIONS AS DESCRIBED IN GS-22-008.
6. THIS PRODUCT IS NOT INTENDED TO BE EXPOSED TO MANUFACTURING SOLDER PROCESSES.
- ⑦ CORING CONFIGURATION IN POLARIZING KEY IS MANUFACTURING OPTION.

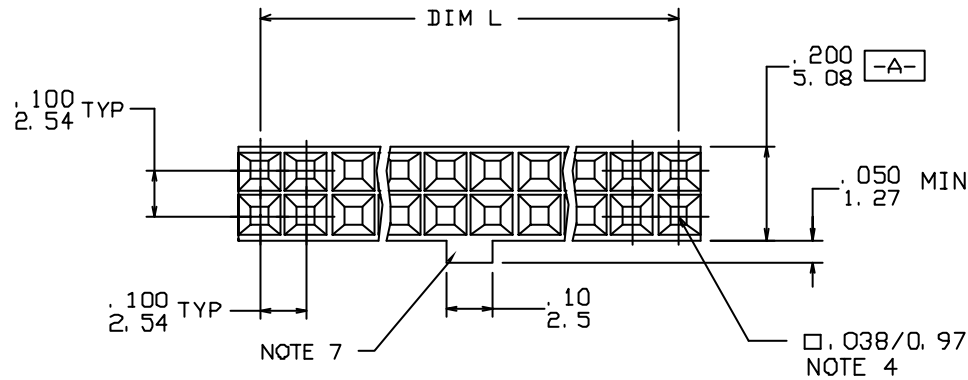

mat'l. code SEE NOTE 2		surface ✓	tolerance	projection INCH/MM	product family PV HOUSINGS
ltr	ecn no	dr	date	tolerances unless otherwise specified	title
E	V03-1380	PJ	2014-12-13	angles	MINI LATCH HOUSING DR POL.
F	V05-0716	TAB	2105-17-29	Linear	.100 [2.54] X .100 [2.54] CC
G	V05-0842	HTB	2005-08-31	0°±2'	scale 3:1
H	V06-0446	HTB	2006-05-16	dr	M. CORNMAN 1990-10-31
J	V07-0533	HTB	2007-08-21	engr	C. TREXLER 1991-08-31
K	F09-0035	LMU	09.06.16	chr	C. TREXLER 1990-10-31
				app	C. TREXLER 1990-10-31
sheet index	revision	K	K		
	sheet	1	2		

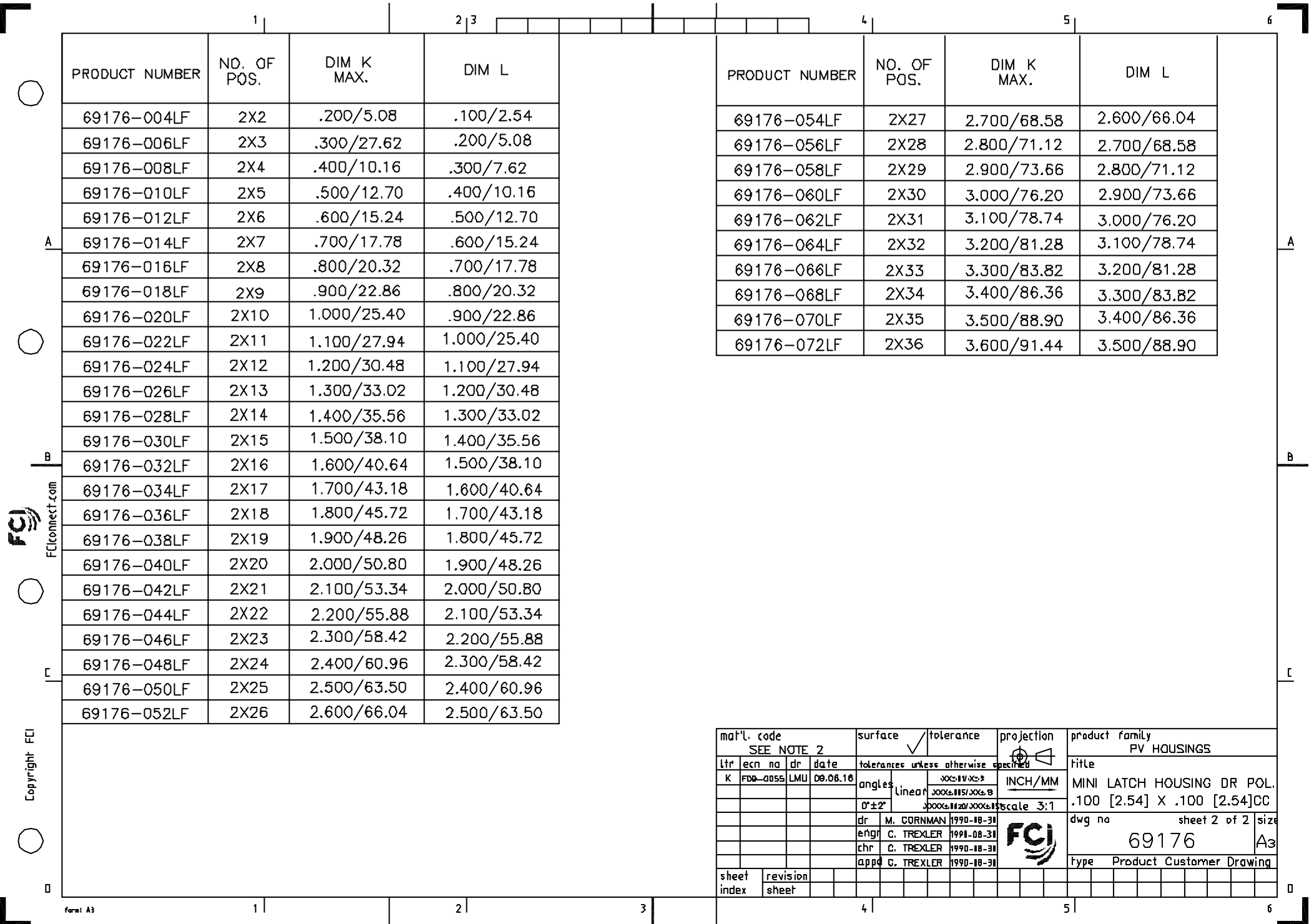

PRODUCT NUMBER	NO. OF POS.	DIM K MAX.	DIM L
69176-004LF	2X2	.200/5.08	.100/2.54
69176-006LF	2X3	.300/27.62	.200/5.08
69176-008LF	2X4	.400/10.16	.300/7.62
69176-010LF	2X5	.500/12.70	.400/10.16
69176-012LF	2X6	.600/15.24	.500/12.70
69176-014LF	2X7	.700/17.78	.600/15.24
69176-016LF	2X8	.800/20.32	.700/17.78
69176-018LF	2X9	.900/22.86	.800/20.32
69176-020LF	2X10	1.000/25.40	.900/22.86
69176-022LF	2X11	1.100/27.94	1.000/25.40
69176-024LF	2X12	1.200/30.48	1.100/27.94
69176-026LF	2X13	1.300/33.02	1.200/30.48
69176-028LF	2X14	1.400/35.56	1.300/33.02
69176-030LF	2X15	1.500/38.10	1.400/35.56
69176-032LF	2X16	1.600/40.64	1.500/38.10
69176-034LF	2X17	1.700/43.18	1.600/40.64
69176-036LF	2X18	1.800/45.72	1.700/43.18
69176-038LF	2X19	1.900/48.26	1.800/45.72
69176-040LF	2X20	2.000/50.80	1.900/48.26
69176-042LF	2X21	2.100/53.34	2.000/50.80
69176-044LF	2X22	2.200/55.88	2.100/53.34
69176-046LF	2X23	2.300/58.42	2.200/55.88
69176-048LF	2X24	2.400/60.96	2.300/58.42
69176-050LF	2X25	2.500/63.50	2.400/60.96
69176-052LF	2X26	2.600/66.04	2.500/63.50

PRODUCT NUMBER	NO. OF POS.	DIM K MAX.	DIM L
69176-054LF	2X27	2.700/68.58	2.600/66.04
69176-056LF	2X28	2.800/71.12	2.700/68.58
69176-058LF	2X29	2.900/73.66	2.800/71.12
69176-060LF	2X30	3.000/76.20	2.900/73.66
69176-062LF	2X31	3.100/78.74	3.000/76.20
69176-064LF	2X32	3.200/81.28	3.100/78.74
69176-066LF	2X33	3.300/83.82	3.200/81.28
69176-068LF	2X34	3.400/86.36	3.300/83.82
69176-070LF	2X35	3.500/88.90	3.400/86.36
69176-072LF	2X36	3.600/91.44	3.500/88.90

mat'l. code SEE NOTE 2				surface <input checked="" type="checkbox"/>		tolerance		projection		product family PV HOUSINGS			
title				tolerances unless otherwise specified		INCH/MM		MINI LATCH HOUSING DR POL.					
K FDB-0055 LMU 06.08.16				angles linear		scale 3:1		.100 [2.54] X .100 [2.54]CC					
				dr M. CORNMANN 1990-08-31		FCJ		dwg no 69176 sheet 2 of 2 size A3					
				engr C. TREXLER 1991-08-31				type Product Customer Drawing					
				chr C. TREXLER 1990-08-31									
				app C. TREXLER 1990-08-31									
sheet index		revision sheet											

Copyright FCJ
 FCconnect.com