

- > Port size: 1/4" ... 3/4" (ISO G/PTF)
- > High efficiency coalescing filters
- > Coalescing element removes sub-micron particles and converts oil and water mist to liquid form to drain away
- > Service indicator standard
- > Quick release bayonet bowl



Technical features

Medium:

Compressed air only

Maximum operating pressure:

17 bar (246 psi)

Flow:

See diagrams on page 2

Remaining oil content:

0,01 mg/m³ max at +21°C (+70°F)

Particle removal:

To 0,01 µm

Port sizes:

1/4", 3/8", 1/2" or 3/4"

Drain:

Manual or automatic

Automatic drain conditions:

Pressure to close drain:

> 0,3 bar (4.3 psi)

Pressure to open drain:

< 0,2 bar (2.9 psi)

Minimum air flow to close drain:

0,6 dm³/s (1.3 scfm)

Service life indicator:

Mechanical standard

Bowl size:

0,2 litre (7 fluid oz)

Ambient/Media temperature:

-20° ... +65°C (-4° ... +149°F)

Air supply must be dry enough to avoid ice formation at temperatures below +2°C (+35°F).

Materials:

Body and yoke: Zinc alloy

Connection piece: Aluminium

Metal bowl: Aluminium

Element: Composite

Prismatic liquid level indicator:

Grilamid

Elastomers: NBR

Technical data, standard models

Symbol	Port size	Size	Filter element (µm)	Flow * (dm ³ /s)	Bowl	Drain	Weight (kg)	Model
	G1/4	—	0,01	16	Metal	Manual	1,48	F64C-2GD-MD0
	G3/8	—	0,01	28	Metal	Manual	1,70	F64H-3GD-MD0
	G1/2	Basic	0,01	28	Metal	Manual	1,67	F64H-4GD-MD0
	G3/4	—	0,01	28	Metal	Manual	2,01	F64H-6GD-MD0
	Without yoke	—	0,01	—	Metal	Manual	1,24	F64C-NND-MD0
	Without yoke	—	0,01	—	Metal	Manual	1,24	F64H-NND-MD0
	G1/4	—	0,01	16	Metal	Automatic	1,48	F64C-2GD-AD0
	G3/8	—	0,01	28	Metal	Automatic	1,70	F64H-3GD-AD0
	G1/2	Basic	0,01	28	Metal	Automatic	1,67	F64H-4GD-AD0
	G3/4	—	0,01	28	Metal	Automatic	2,01	F64H-6GD-AD0
	Without yoke	—	0,01	—	Metal	Automatic	1,24	F64C-NND-AD0
	Without yoke	—	0,01	—	Metal	Automatic	1,24	F64H-NND-AD0

* Maximum flow at 6,3 bar (91 psi) - guaranty optimum oil removal performance.

Option selector

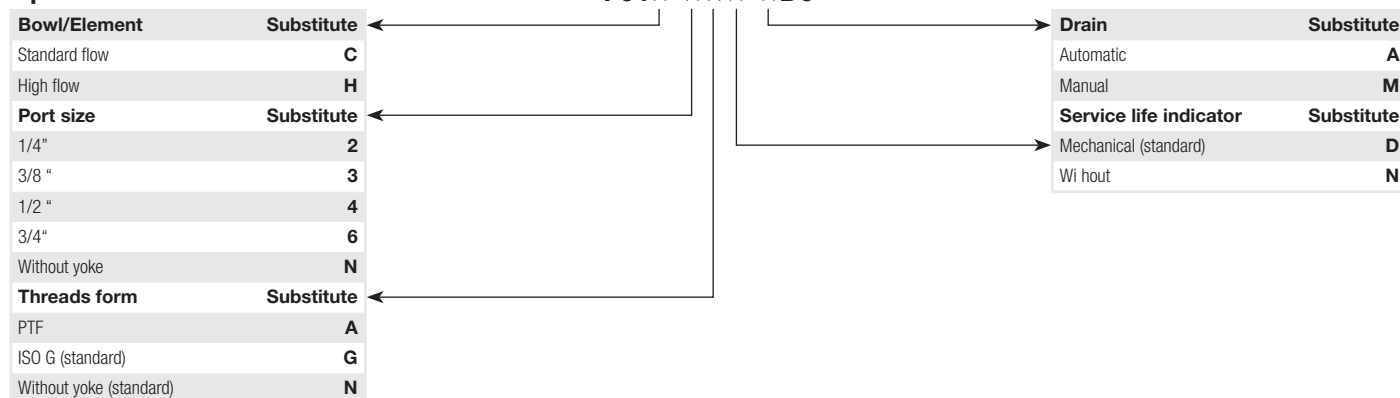

Flow characteristics

F64C Port size: 1/4"

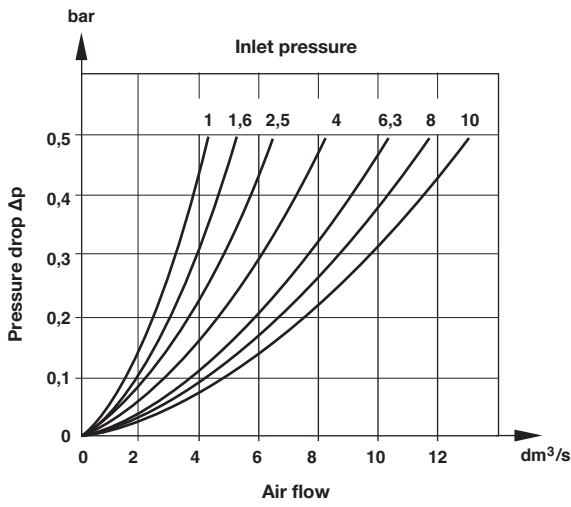

F64H Port size: 1/2"

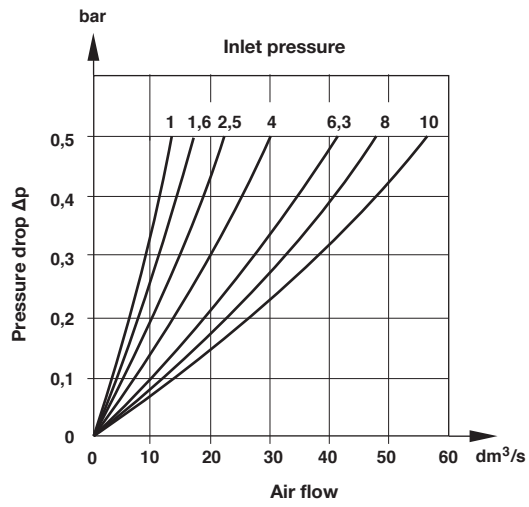

Typical performance characteristics

Inlet pressure (bar)	Maximum flow (dm³/s)*	
	F64C	F64H
1	6,4	11,2
3	11,0	19,3
5	14,3	24,9
6,3	16,0	28,0
7	16,9	29,5
9	19,1	33,5

* Maximum flow to maintain stated oil removal performance.

Accessories and service kit



Accessories

	Models with G-thread Single yoke	Double yoke	3/2 Shut-off valve Threaded inlet only	Threaded outlet only	End connector kit	Rear entry bracket kit
Thread	5				2	8
G1/4	Y64A-2GA-N1N	Y64A-2GA-N2N	T64T-2GB-P1N	T64T-2GC-P1N	—	—
G3/8	Y64A-3GA-N1N	Y64A-3GA-N2N	T64T-3GB-P1N	T64T-3GC-P1N	—	—
G1/2	Y64A-4GA-N1N	Y64A-4GA-N2N	T64T-4GB-P1N	T64T-4GC-P1N	74505-50	—
G3/4	Y64A-6GA-N1N*	Y64A-6GA-N2N*	T64T-6GB-P1N	T64T-6GC-P1N	74505-53	18-026-981
1/4 PTF	Y64A-2AA-N1N	Y64A-2AA-N2N	T64T-2AB-P1N	T64T-2AC-P1N	—	—
3/8 PTF	Y64A-3AA-N1N	Y64A-3AA-N2N	T64T-3AB-P1N	T64T-3AC-P1N	—	—
1/2 PTF	Y64A-4AA-N1N	Y64A-4AA-N2N	T64T-4AB-P1N	T64T-4AC-P1N	74505-52	—
3/4 PTF	Y64A-6AA-N1N*	Y64A-6AA-N2N*	T64T-6AB-P1N	T64T-6AC-P1N	74505-55	—

*These yokes are supplied with two end connector kits as standard.

Bracket mounting	Nut	Yoke connector kit	Porting block	Adjustable pressure switch	Padlock with two keys
1	4	9			
74504-50	74502-89	74503-51	74507-50	4346-99	0613633 (brass)

Service kit

Service kit F64C	Service kit F64H
F64C-KITA0C	F64H-KITA0C

Basic dimensions

F64C

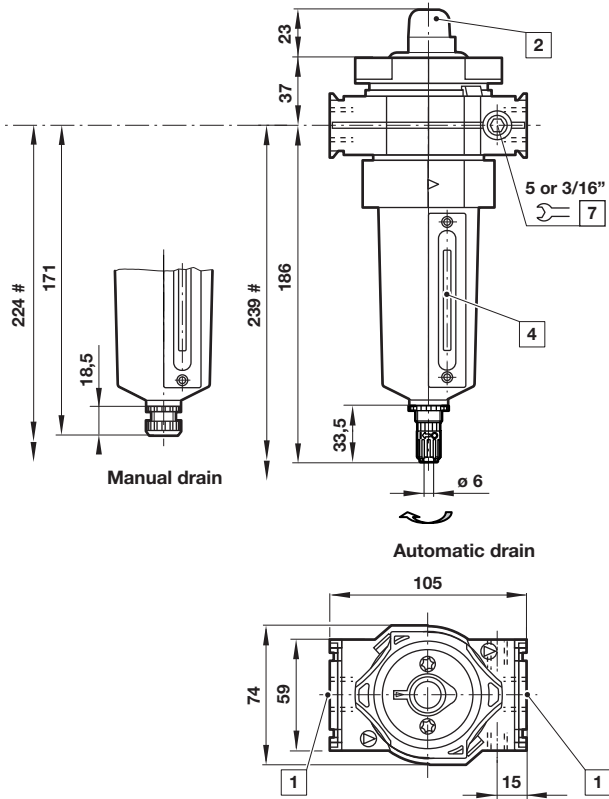

F64H

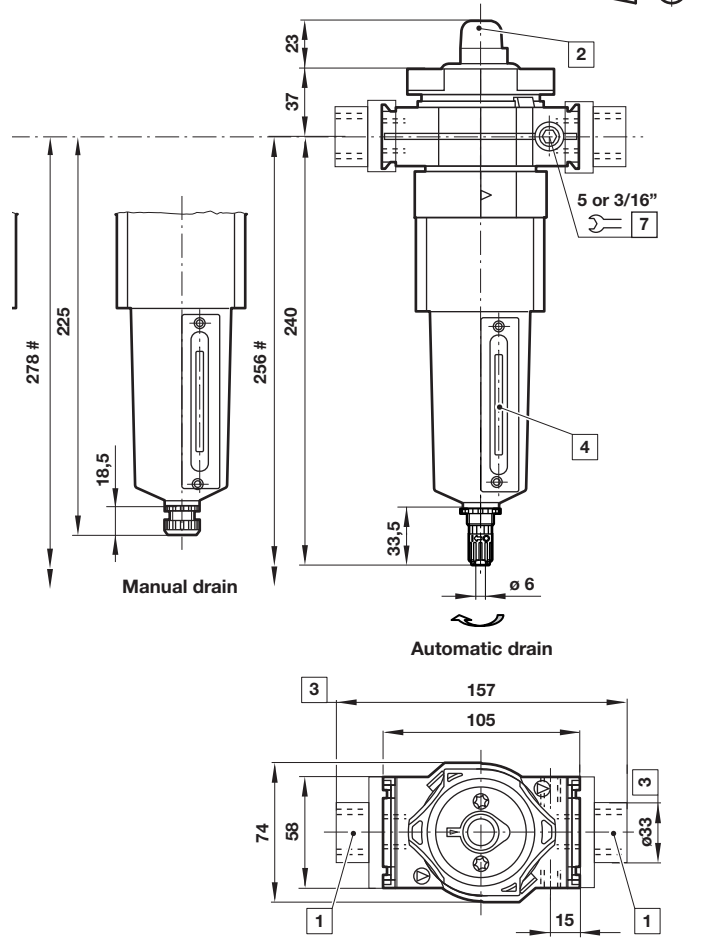

Dimensions in mm
 Projection/First angle



Minimum clearance required to remove bowl

- 1 Main ports 1/4", 3/8", 1/2" or 3/4"
- 3 For main ports 3/4" only
- 4 Sight glass
- 7 Gauge port 1/8"

Single yoke with bracket mounting

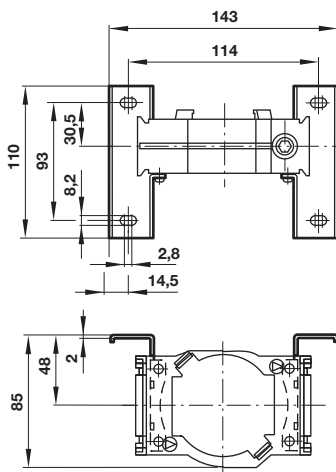

Double yoke with bracket mounting

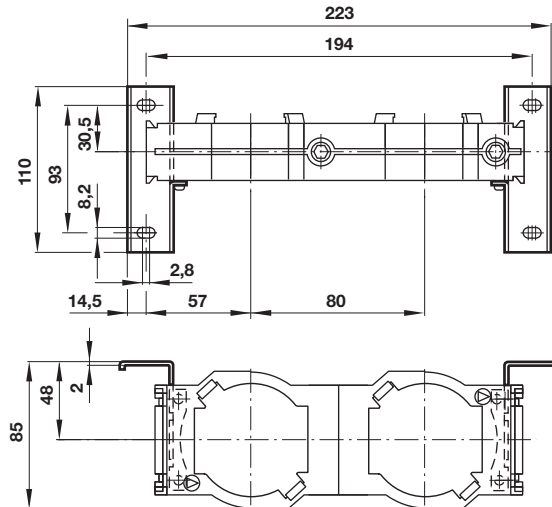

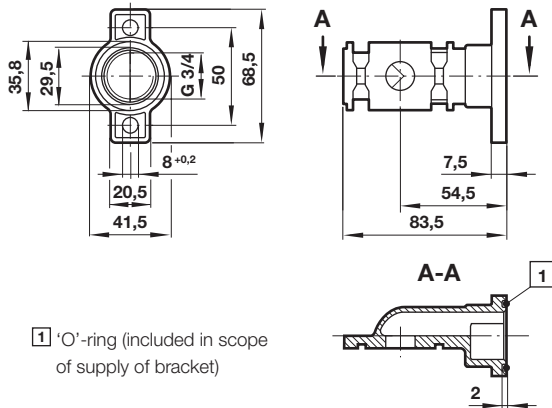
Rear entry bracket
18-026-981

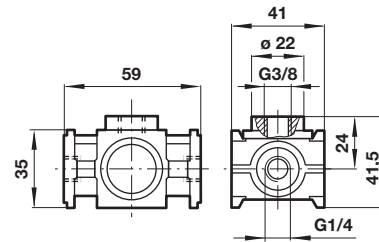
Porting block
74507-50

 Dimensions in mm
 Projection/First angle

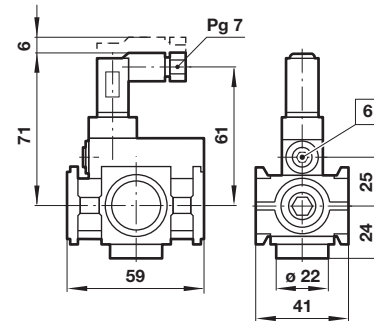
Adjustable pressure switch
4346-99

Voltage	24 V d.c./240 V a.c.
Current	0,5 A (d.c.); 5 A (a.c.)
Pressure range	2 ... 10 bar
Repeatability	2% of full set point range at 20°C
Average deadband	0,8 ... 1,7 bar
Electrical connection (corresponding to choosen coil)	EN 175301-803 - Form C, 15 mm
Degee of protection:	IP65
Adjustable	Standard
Material	Body: Aluminium, Elastomers: NBR

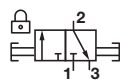

[6] Adjusting screw

3/2 Shut-off valve

Symbol	A	B	ø C	Model
	G1/4	48	27	T64T-2G*-P1N
	G3/8	48	27	T64T-3G*-P1N
	G1/2	48	27	T64T-4G*-P1N
	G3/4	51	33	T64T-6G*-P1N

* B = Threaded inlet only, C = Threaded outlet only

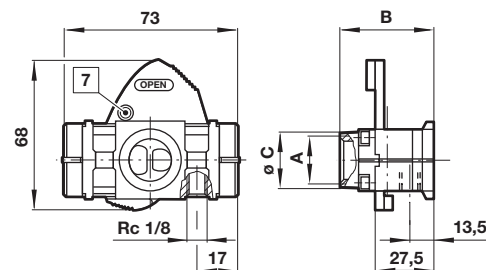

[7] Padlock hole ø7,5 mm

Warning

These products are intended for use in industrial compressed air systems only. Do not use these products where pressures and temperatures can exceed those listed under

»Technical features/data«.

Before using these products with fluids other than those specified, for non-industrial applications, life-support systems or other applications not within published specifications, consult IMI NORGREN.

Through misuse, age, or malfunction, components used in fluid power systems can fail in various modes.

The system designer is warned to consider the failure modes of all component parts used in fluid power systems and to provide adequate safeguards to prevent personal injury or damage to equipment in the event of such failure.

System designers must provide a warning to end users in the system instructional manual if protection against a failure mode cannot be adequately provided.

System designers and end users are cautioned to review specific warnings found in instruction sheets packed and shipped with these products.