

# **E**BLOCKS<sup>®</sup>

MIDI interface board

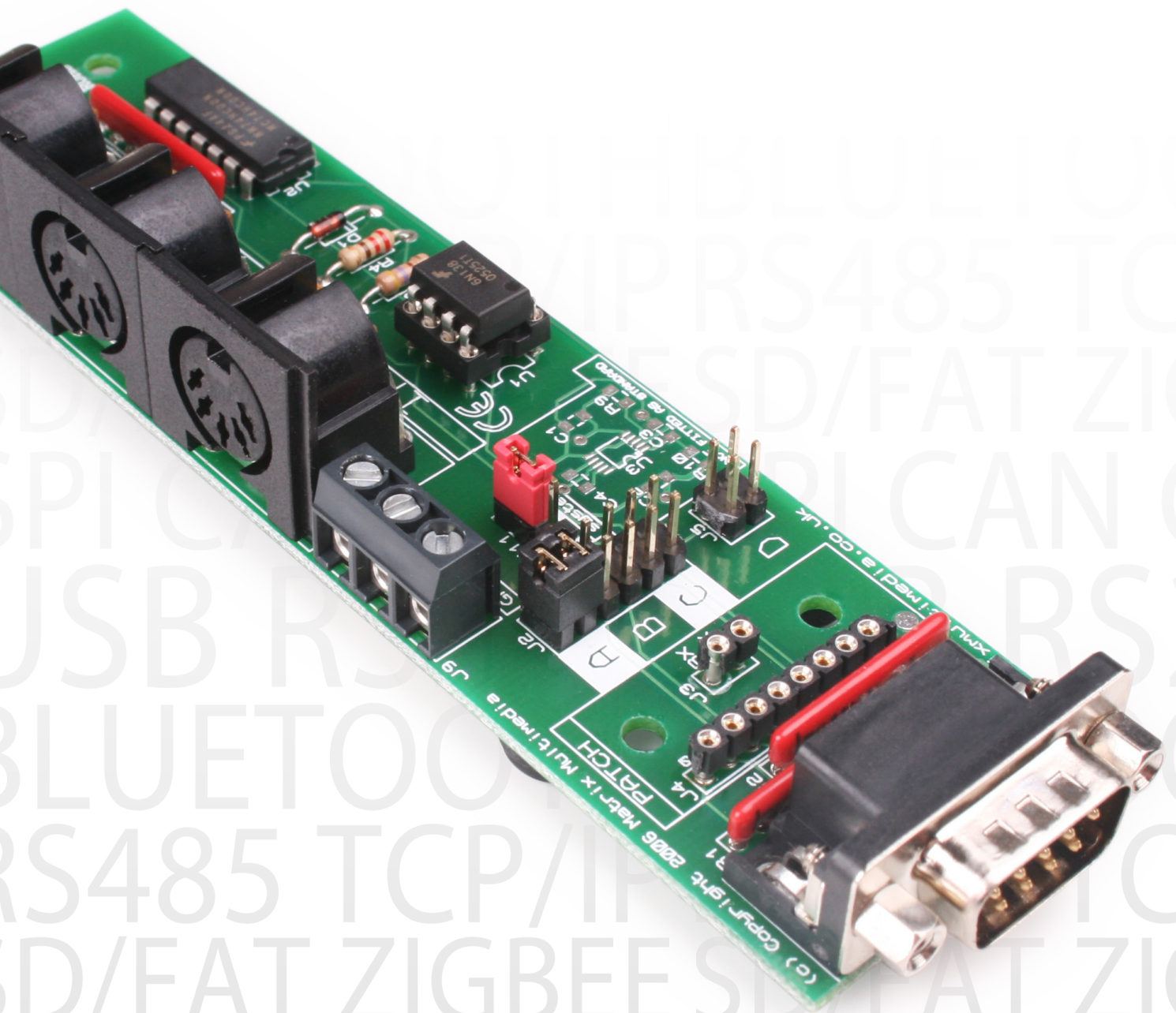



# About this document

This document concerns the EB021 E-blocks MIDI interface board.

## 1. Trademarks and copyright

PIC and PICmicro are registered trademarks of Arizona Microchip Inc. E-blocks is a trademark of Matrix Technology Solutions Ltd.

## 2. Disclaimer

The information provided within this document is correct at the time of going to press. Matrix TSL reserves the right to change specifications from time to time.

## 3. Testing this product

It is advisable to test the product upon receiving it to ensure it works correctly. Matrix provides test procedures

for all E-blocks, which can be found in the Support section of the website.

## 4. Product support

If you require support for this product then please visit the Matrix website, which contains many learning resources for the E-blocks series. On our website you will find:

- How to get started with E-blocks - if you are new to E-blocks and wish to learn how to use them from the beginning there are resources available to help.
- Relevant software and hardware that allow you to use your E-blocks product better.
- Example files and programs.
- Ways to get technical support for your product, either via the forums or by contacting us directly.

# Board layout

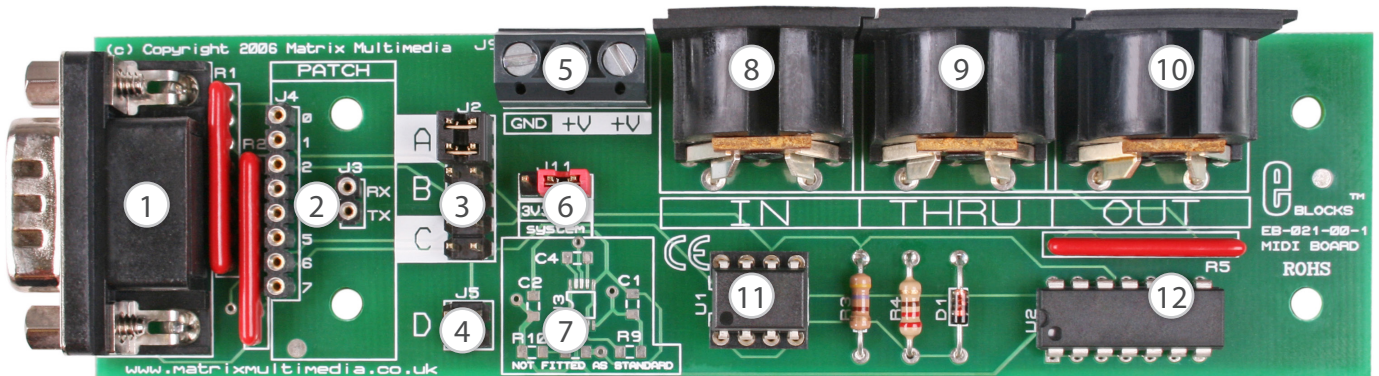

- |   |   |
|---|---|
| 1. 9-way downstream D-type connector                | 7. 3.3 volt compatible circuit (not fitted as standard) |
| 2. Patch system                                     | 8. MIDI input port                                      |
| 3. Receive and transmit selection jumper pins       | 9. MIDI through port                                    |
| 4. Patch receive and transmit selection jumper pins | 10. MIDI output port                                    |
| 5. Power screw terminals                            | 11. Optical isolator chip                               |
| 6. MIDI VCC power selection jumper                  | 12. Quad NAND logic chip                                |

	Jumper at A	Jumper at B	Jumper at C	Jumper at D
TX	Pin 5	Pin 2	Pin 6	Patch
RX	Pin 2	Pin 1	Pin 7	Patch

General guide for RX and TX settings

# General information

This E-block allows investigation of MIDI message and control protocols. MIDI stands for Musical Instrument Digital Interface and comprises of a standard communication protocol that enables electronic instruments such as synthesizers, samplers, sequencers and drum machines from any manufacturer to communicate not only with one another, but also with computers. The MIDI board can transit, receive and pass on MIDI data via the three five pin DIN connectors. These connectors are labelled IN, OUT and THRU.

A set of jumper links are available which allow the MIDI E-block to easily be set for all PICmicro® microcontroller compatible devices. The on board patch system makes this board compatible with numerous other devices.

## 1. Features

- MIDI input
- MIDI output
- MIDI through
- Optical isolation to prevent ground loops

## 2. Programming guide

MIDI devices transmit and receive commands via a serial method of communication. Each command is eight bits long with a start and a stop bit. The start bit is a logic 0 and the stop bit is a logic 1. Each bit should remain on the serial line for 32 microseconds meaning that a byte of data including start and stop bits take 320 microseconds to receive. MIDI messages generally comprise of a command byte followed by up to 2 data bytes. There is a complication with the MIDI protocol involving real time messages. These real time messages can occur at any time and may be received between a command byte and its data byte so this has to be taken into account

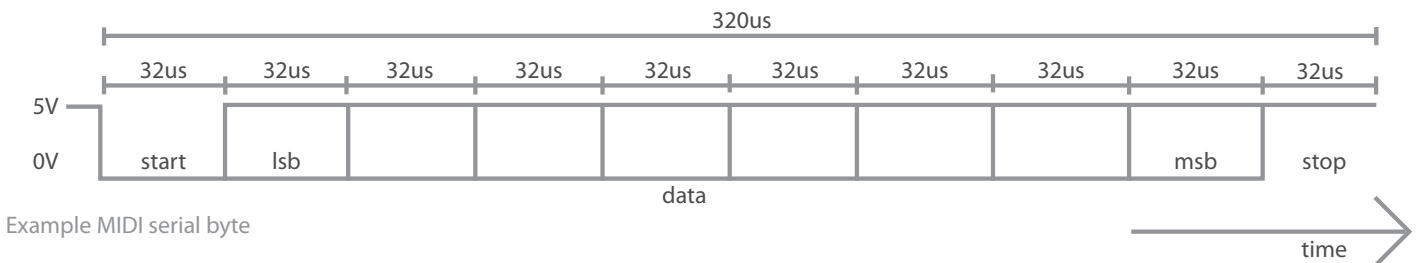
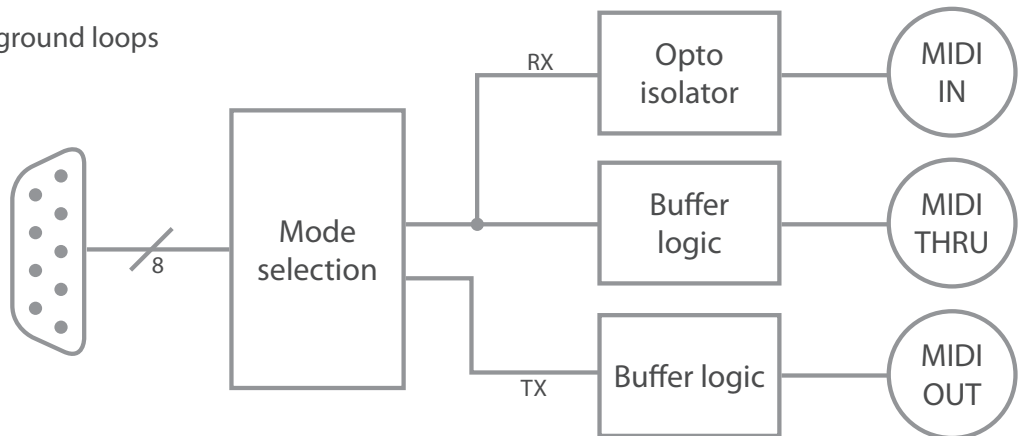

Example MIDI serial byte

# Circuit description

The EB021 MIDI interface circuit can be observed on page 6. The circuit is made up of three sections: connectors, optical isolator and logic buffering.

## 1. Connectors

The design of this product is to enable you to use it with many standard PICmicro® microcontroller devices. This is achieved by identifying the PICmicro® that you are using and which input output pins are available. Depending on which I/O pins are free you can configure the jumpers on the MIDI board to route access to the RX and TX control lines.

The patch system allows the user to route RX and TX to any 8 of the bits that they require. This allows great flexibility.

## 2. Optical isolator circuit

The optical isolator chip that is used is a 6N138. It contains an active light emitting diode and a light dependant sensor. Used together these components act to convert

the electrical signal coming into the MIDI IN port into a light based signal and then back into an electrical signal. This method of converting the signal medium is very useful as it firstly prevents earth loops that would incur oscillations within the signal, and secondly as it helps to prevent the PICmicro® becoming damaged from incorrect wiring or over current.

## 3. Logic buffering

The logic buffer chip that is used is a 74HC00 and is made up of four standard NAND gates. The buffer chip is important for the circuits operation as it provides a way of double buffering the output to the MIDI OUT and the MIDI THRU. This helps boost the current of the signal making the signal stronger at the remote end allowing for easier reception.

## 4. 3.3V operation

The MIDI board is not 3.3V compatible. However users can ask for a MIDI board fitted with extra circuitry, which allows for 3.3V compatible operation.

# Protective cover

Most of the boards in the E-blocks range can be fitted with a plastic cover as an optional extra. These covers are there to protect your E-blocks board therefore extending the life of the board. The covers also prevent the removal of external components while still allowing for the adjustment of applicable parts on the board.

12mm M3 spacers, anti-slip M3 nuts and 25mm M3 bolts can be used to attached the cover to the board. These are not included but can be bought separately from our website.

The order code for the EB021 MIDI board is EB721.

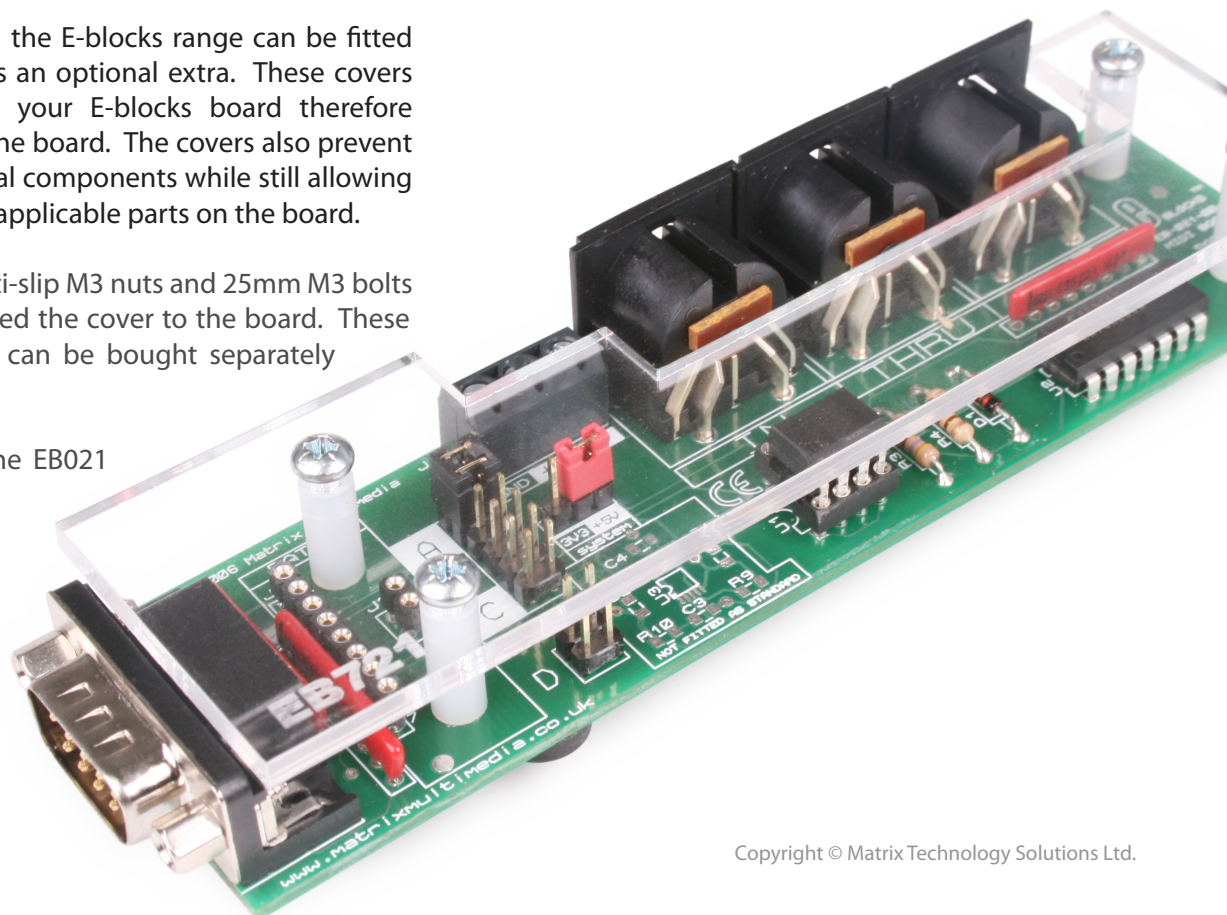

# Circuit diagram

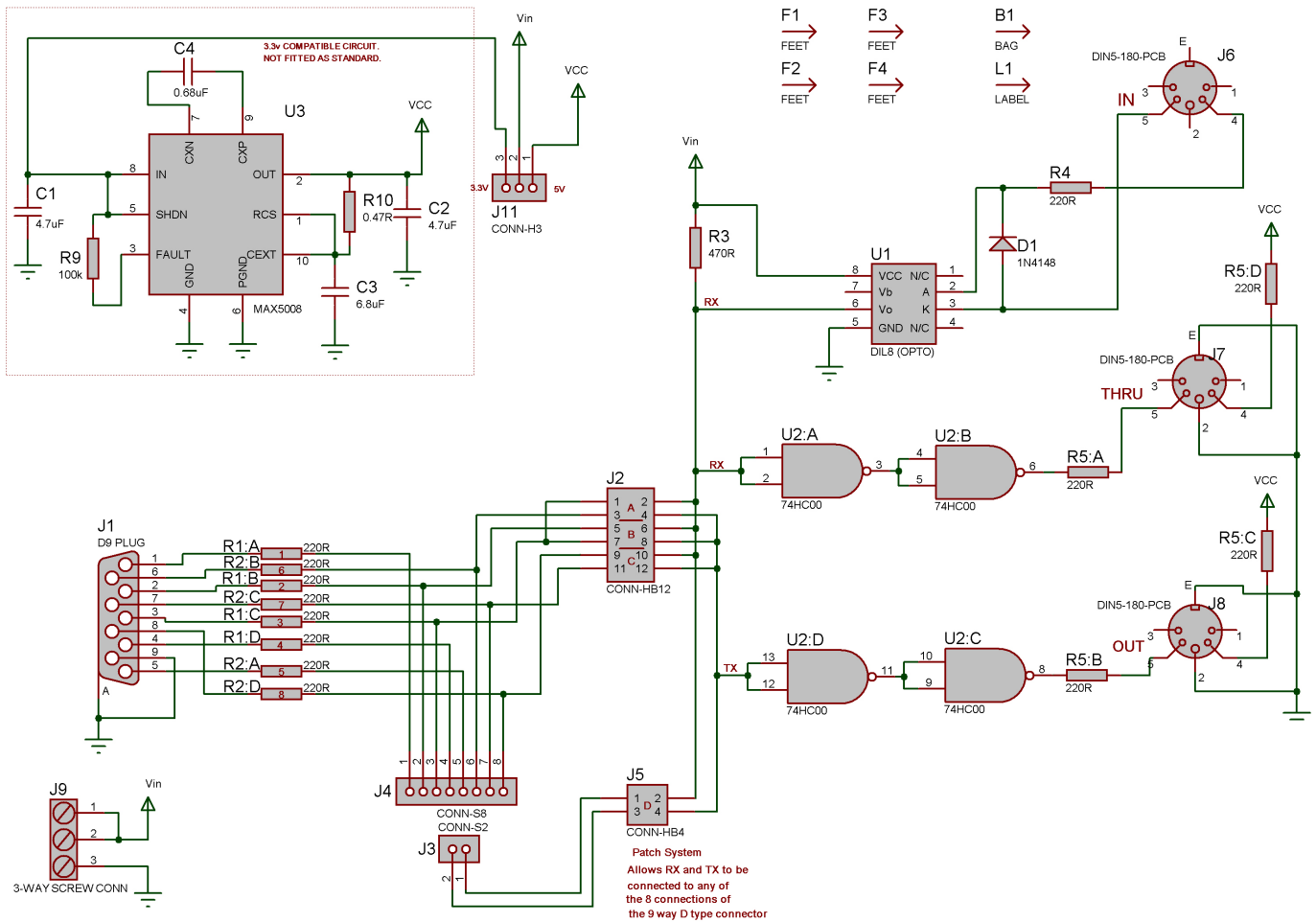



Matrix Technology Solutions Ltd.  
The Factory  
33 Gibbet Street  
Halifax, HX1 5BA, UK

t: +44 (0)1422 252380  
e: sales@matrixtsl.com

[www.matrixtsl.com](http://www.matrixtsl.com)

EB021-30-3