

26" PRO35™ DEEP TOOL CHEST 5 DRAWERS RED



- Five robust fully extendable drawers, each supporting 30 kg, with smooth running ball bearing slides
- An EVA mat in every drawer for reduced noise and tool movement
- Constructed from heavy gauge steel treated with a 5-step phosphate-free rust prevention process and a powder coat finish
- Features a 3-digit combination lock, recessed handles, and rubber feet for security and mobility
- Compatible with TengTools Tool Control System for customized tool organization

The TengTools 26" PRO35™ deep tool chest TST26R5F, finished in matte red, is a premium tool storage solution designed for professional use. Measuring 660 mm in width, 455 mm in depth, and 483 mm in height, this tool chest integrates seamlessly into any professional workshop setting. This unit features a unique drop front with the TengTools logo, which covers the drawers when the box is closed, adding an extra layer of protection and a sleek appearance. It houses five fully extendable robust drawers: two with a height of 50 mm and three with a height of 75 mm. Each drawer has a capacity of 30 kg, suitable for a wide range of tools and accessories. They operate on smooth running ball bearing slides, ensuring a reliable opening and closing experience even under heavy loads. Every drawer is lined with an EVA mat that reduces tool movement during use and transport. The tool chest is compatible with the flexible TengTools Tool Control System, including both the space-saving TT sets and the protective FOAM sets, which features high-density EVA in three contrasting layers. The drawers are tailored to accommodate four TengTools TCI modules plus a TengTools TCX4 module in each drawer, allowing for maximum organization and efficient tool retrieval. This allows professionals to build their ultimate tool kit tailored to any need or setting. Constructed from heavy gauge, top-quality steel, the unit is built to withstand the rigors of a professional workshop. It is treated with a phosphate free 5-step rust prevention process and powder coated, ensuring longevity and maintaining its pristine appearance over time. Additional features include a 3-digit combination lock for enhanced security, recessed side handles that facilitate easy mobility, and rubber feet for stability. The drawers are equipped with durable aluminium handles, contributing to the unit's overall appearance and professional user experience.

General information

Country of origin: Taiwan
Barcode: 5020385215146
Tarriff code Europe: 9403208000
ECCN US: EAR99
UNSPSC: 24112401

Dimensions

Net weight (g): 44400
Width (mm): 660
Depth (mm): 455
Height (mm): 483
Number of drawer: 5
Drawer capacity: 5 × 30 kg
Drawer depth: 5 × 380 mm
Drawer height: 2 × 50 mm, 3 × 75 mm
Drawer width: 5 × 575 mm

Attributes

Product type: Mobile Tool Storage
Colour: Red
Type of storage: Tool Chest

Features



Technical changes and errors may occur. 01-08-2024 20:00



DESIGNED IN SWEDEN

TengTools is a Swedish company present in more than 30 markets worldwide, and offers hand tools in smart storage solutions for demanding professionals within the automotive, maintenance and engineering sectors, as well as motor sport enthusiasts who aspire to use the same tools as top mechanics across the globe.



Sandbergsvägen 3
 441 39 Alingsås, Sweden

ADDITIONAL IMAGES



WWW.TENGTTOOLS.COM



SPARE PART LIST

TST26R5F

Version: 3



WWW.TENGTTOOLS.COM

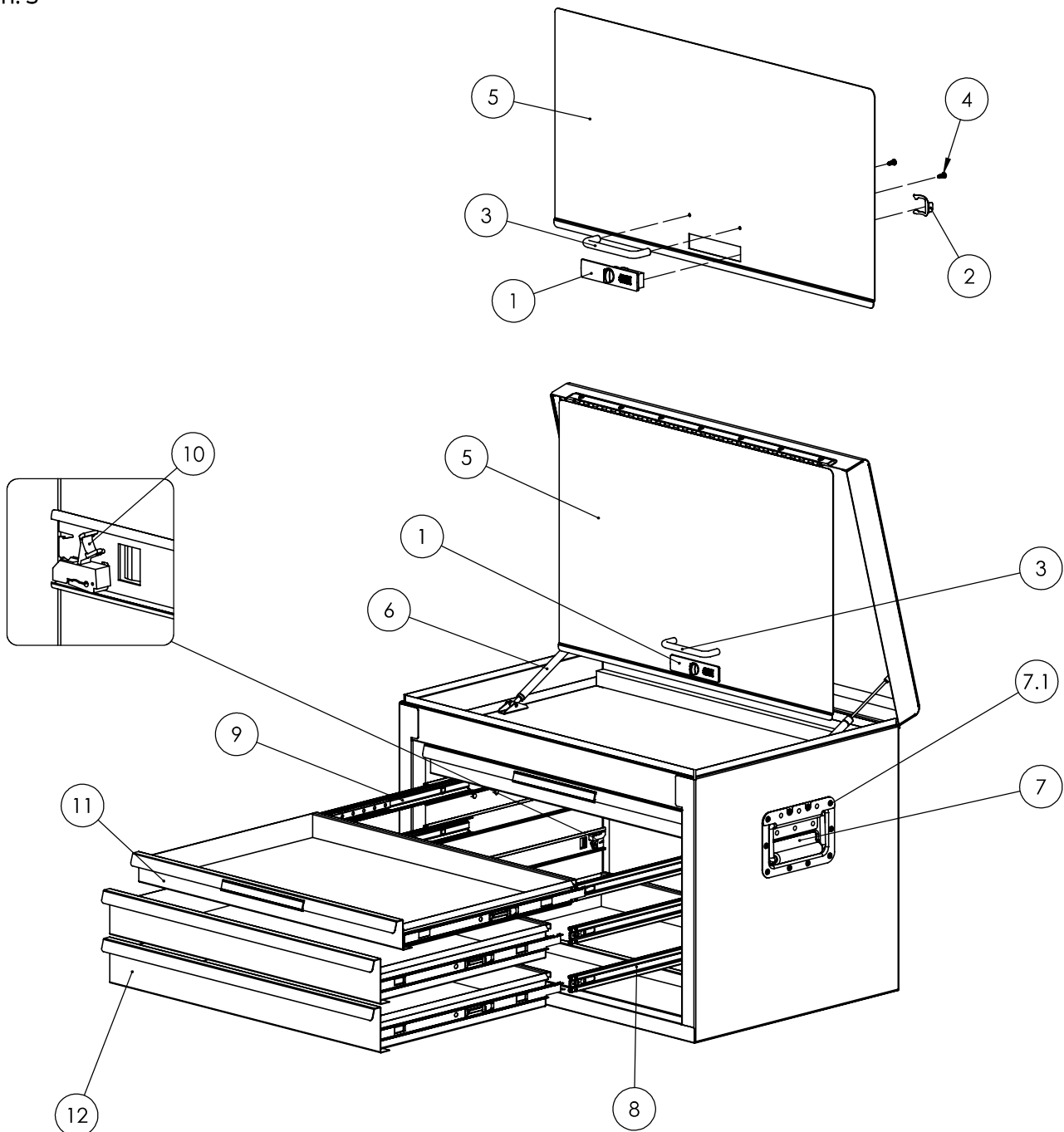

POS	DESCRIPTION	ITEM ID
1A	Combination lock 90°	TC-90CLOCK
1B	Key cylinder lock 90° (optional)	TC-90KEYLOCK
2	Cam for lock (included in Pos 1)	TC803-05
3	Drop front handle Black	TC805NFXBK1-10
4	Screws for drop fron handle (2 pcs)	TC606-10
5	Drop front 26" with Logo Red	TC805NFX-11
6	Hydraulic Lid Stay (2 pcs)	TC805NFX-12
7	Retractable side handle	TCDSHA
7.1	Rivets: 4,8mm x 7,4mm Black (10 pcs)	-
8	Slider 16" 36 mm Right (1pc)	TCW806N-06
9	Slider 16" 36 mm Left (1pc)	TCW810N-06
10	Clip for slider (included in Pos 9)	TC803N-13
11	Drawer 575 x 380 x 50 mm Red	TST26R-50
12	Drawer 575 x 380 x 75 mm Red	TSW26R-75
13A	Aluminium drawer handle (3 pcs)	ALUE803
13B	Aluminium drawer handle (4 pcs)	ALUE804