

# Housing - HC-STA-B10-CHWS-1TTP29-ELC-AL - 1412589

Please be informed that the data shown in this PDF Document is generated from our Online Catalog. Please find the complete data in the user's documentation. Our General Terms of Use for Downloads are valid (<http://phoenixcontact.com/download>)



Coupling housings B10, with single locking latch, material: Die-cast aluminum, salt water resistant, cable outlets: 1, straight, height: 73 mm, cable gland: none, support sleeve: no, 1x Pg29, Standard

## Your advantages

- good shielding in the event of electromagnetic interference



## Key Commercial Data

Packing unit	1 pc
GTIN	
GTIN	4055626030647
Weight per Piece (excluding packing)	201.700 g
Custom tariff number	85389099
Country of origin	Poland

## Technical data

### Dimensions

Height	73 mm
Width	44 mm
Length	73 mm

### Ambient conditions

Degree of protection (IP)	IP66
	IP67
Degree of protection (NEMA)	4 (UL 50e)
	4X (UL 50e)
	12 (UL 50e)
Ambient temperature (operation)	-40 °C ... 125 °C

### General

# Housing - HC-STA-B10-CHWS-1TTP29-ELC-AL - 1412589

## Technical data

### General

Note	For contact inserts HC-B10, BB18, DD42, M, K8/24
Size	B10
Housing type	Coupling housings
Color	gray aluminum
Locking type	with single locking latch
No. of cable outlets	1
Cable outlet	straight
Screw connection	none
Type of the screw connection	1x Pg29
Housing material	Die-cast aluminum, salt water resistant
Housing surface material	uncoated
Seal material	NBR, conductive
Material lock	PA
Flammability rating according to UL 94	V0 (Interlock)

### Environmental Product Compliance

China RoHS	Environmentally Friendly Use Period = 50 years
	For details about hazardous substances go to tab "Downloads", Category "Manufacturer's declaration"

## Drawings

Dimensional drawing

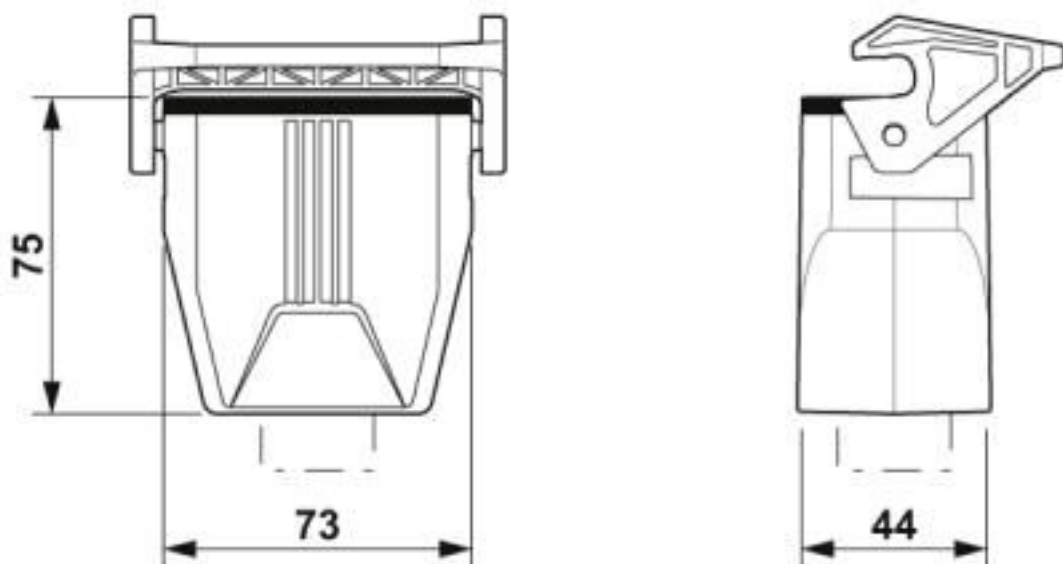

Dimensional drawing

# Housing - HC-STA-B10-CHWS-1TTP29-ELC-AL - 1412589

## Classifications

### eCl@ss

eCl@ss 10.0.1	27440202
eCl@ss 5.1	27261200
eCl@ss 6.0	27261200
eCl@ss 7.0	27440202
eCl@ss 8.0	27440202
eCl@ss 9.0	27440202

### ETIM

ETIM 5.0	EC000437
ETIM 6.0	EC000437
ETIM 7.0	EC000437

### UNSPSC

UNSPSC 13.2	31261501
UNSPSC 18.0	31261501
UNSPSC 19.0	31261501
UNSPSC 20.0	31261501
UNSPSC 21.0	31261501

## Approvals

### Approvals

---

#### Approvals

UL Recognized / cUL Recognized / EAC / DNV GL / cULus Recognized

---

#### Ex Approvals

---

### Approval details

UL Recognized		<a href="http://database.ul.com/cgi-bin/XYV/template/LISEXT/1FRAME/index.htm">http://database.ul.com/cgi-bin/XYV/template/LISEXT/1FRAME/index.htm</a>	E255026
---------------	--	---	---------

cUL Recognized		<a href="http://database.ul.com/cgi-bin/XYV/template/LISEXT/1FRAME/index.htm">http://database.ul.com/cgi-bin/XYV/template/LISEXT/1FRAME/index.htm</a>	E255026
----------------	--	---	---------

# Housing - HC-STA-B10-CHWS-1TTP29-ELC-AL - 1412589

## Approvals

EAC		RU C- DE.AI30.B.01102
-----	--	--------------------------

DNV GL		<a href="https://approvalfinder.dnvgl.com/">https://approvalfinder.dnvgl.com/</a>	TAE000037S
--------	--	---	------------

cULus Recognized	
------------------	--

## Accessories

### Accessories

#### Full screw connection

Cable gland - G-INS-PG29-M68N-NNES-S - 1411176



Cable gland, cable gland material: Nickel-plated brass, external cable diameter 18 mm ... 25 mm, shielding: no, connecting thread: Pg29, color: silver, with O-ring

Cable gland - G-INSEC-PG29-M68N-NNES-S - 1411201



Cable gland, cable gland material: Nickel-plated brass, external cable diameter 18 mm ... 25 mm, shielding: yes, connecting thread: Pg29, color: silver, with O-ring

## Housing latches

Replacement part - HC-STA-B10-SL-PLBK - 1412804



Single locking latch for B10 housing, HC-EVO....AL and HC-STA....AL

## Labeled device marker

## Housing - HC-STA-B10-CHWS-1TTP29-ELC-AL - 1412589

### Accessories

Plastic label - US-EMLP (20X9) CUS - 0830085



Plastic label, can be ordered: by card, white, labeled according to customer specifications, mounting type: adhesive, lettering field size: 20 x 9 mm, Number of individual labels: 75

---

### Seal

Profile gasket - HC-B10-SP-CBK - 1411479



Profile gasket for HEAVYCON EVO supporting base element type B10, conductive