

## Powersaver

**Boost (PSB)**  
**Boost Maxi (PSB MAXI)**



## Powersaver

**Daily (PSD)**  
**Weekly (PSW)**  
**24/7 (PS24/7)**



## Installation Instructions

### WARNING - ISOLATE THE MAINS BEFORE INSTALLATION & SERVICING

THIS INSTALLATION SHOULD BE CARRIED OUT BY A SUITABLY QUALIFIED PERSON, IN ACCORDANCE WITH THE CURRENT EDITION OF THE IEE WIRING REGULATIONS.

WARNING: All Powersaver products must be earthed, using the earth terminals at the rear of the switch. The following cabling is recommended:

L & N - 1.5mm<sup>2</sup> - 4.0mm<sup>2</sup> fixed

↓ ↓ - 1.5mm<sup>2</sup> - 2.5mm<sup>2</sup> flexible

(retro fit applications (only in conjunction with 143609 surface box)

L Out & N Out - 1.5mm<sup>2</sup> - 2.5mm<sup>2</sup> fixed or flexible

Provision must be made in the fixed wiring for a means of disconnection from the supply having a contact separation of at least 3mm on all poles. This can be provided by the consumer unit.

The Powersaver product range are independently mounted time switches, of electronic construction, which can be surface or flush mounted. For flush fitting a metal box of at least 32mm internal depth should be fitted with the earth terminal at the bottom.

For surface mounting use a patress box with a minimum internal depth of 32mm.

Do not remove the Powersaver from its packaging until the patress/wall box is fitted and cleared of dust & debris. The Powersaver range is suitable for use in a normal pollution situation.

The cable clamp at the rear of the unit is for outgoing cables to the appliance only.

**CONNECTION WARNING:** Isolate mains before installing. Supply terminals are for fixed wiring only. Load terminals are for fixed or flexible wiring. Remove 8mm of insulation from each wire & twist any multiple connection together.

All earth conductors must be sleeved (green/yellow) and connected to earth terminals provided on rear of switch. Fit the Powersaver to the patress box using screws provided.

When cutting the aperture for the output flexible cord ensure no sharp edges remain.

**PLEASE NOTE:** This product is not suitable for mounting on unearthed metal or metallic surfaces.

## Wiring Diagram

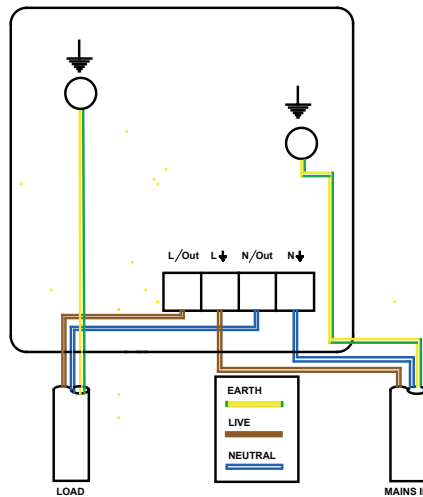

## Installation Diagrams

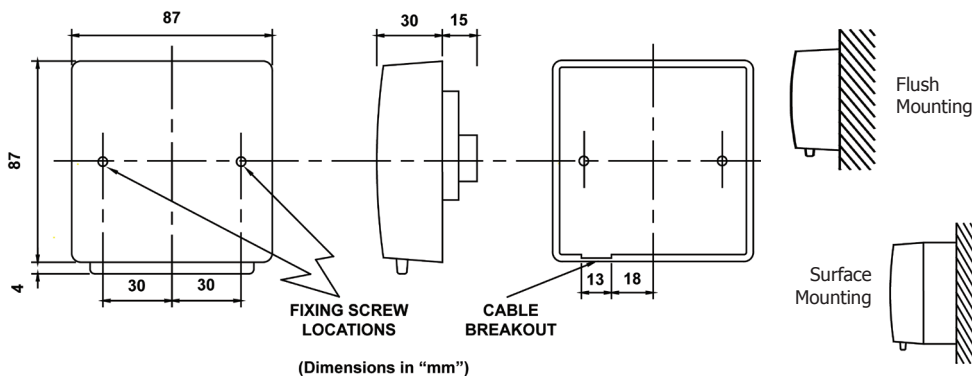

## Programming

### BOOST (PSB)

The Powersaver Boost offers 3 options for the on period duration using the BOOST button.

Press once = ½ hour

Press twice = 1 hour

Press three times = 2 hour

Press four times = Cancel function

While the Boost is active the indicator light will change to show the maximum remaining time; e.g. 2 Hours selected

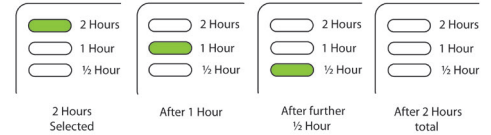

### BOOST MAXI (PSB MAXI)

The Powersaver Boost Maxi performs exactly as the 'Boost' product but offers alternative on period durations using the BOOST button.

Press once = 1 hour

Press twice = 3 hours

Press three times = 5 hours

Press four times = Cancel function

**DAILY, WEEKLY, 24/7 (PSD, PSW, PS24/7)** - See flap label for identification if in doubt

Program Methods:

1. Press SET to exit initial reset display if shown.
2. Press SET to scroll through & review settings in sequence.
3. Press - & + to adjust these settings.
4. 24/7 ONLY - Press BOOST to copy programs into the next day.
5. 24/7 ONLY - Press OFF/ON to skip to a day
6. If a button is not pressed within 30 seconds, the unit will revert back to the normal running state.

### Typical Displays:

Date/Time Setting Mode



Reset/Initial

Set Time

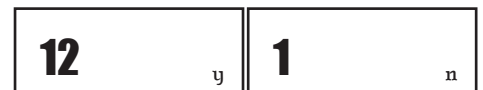

Set Year

Set Month

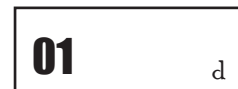

Set Date

Program Setting Mode

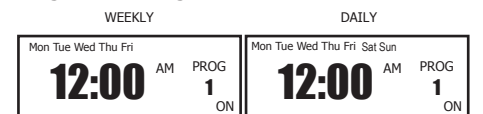

## Programming (cont...)

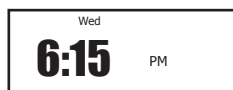

**Normal Display**  
(outwith program)



**Programming Display**  
(during program)



**Boost Mode**



**Holiday Mode**



**Keypad Locked**

### Programming Sequence

#### Daily (PSD)

Time, Year, Month, Day,  
Prog 1on, Prog 1off, Prog 2on, Prog 2off, Prog 3on, Prog 3off,  
Return to normal display

#### Weekly (PSW)

Time, Year, Month, Day,  
Mon-Fri: Prog 1on, Prog 1off, Prog 2on, Prog 2off, Prog 3on, Prog 3off,  
Sat-Sun: Prog 1on, Prog 1off, Prog 2on, Prog 2off, Prog 3on, Prog 3off,  
Return to normal display

#### 24/7 (PS24/7)

Time, Year, Month, Day,  
Mon: Prog 1on, Prog 1off, Prog 2on, Prog 2off, Prog 3on, Prog 3off,  
Tue: Prog 1on, Prog 1off, Prog 2on, Prog 2off, Prog 3on, Prog 3off,  
Wed: Prog 1on, Prog 1off, Prog 2on, Prog 2off, Prog 3on, Prog 3off,  
Thu: Prog 1on, Prog 1off, Prog 2on, Prog 2off, Prog 3on, Prog 3off,  
Fri: Prog 1on, Prog 1off, Prog 2on, Prog 2off, Prog 3on, Prog 3off,  
Sat: Prog 1on, Prog 1off, Prog 2on, Prog 2off, Prog 3on, Prog 3off,  
Sun: Prog 1on, Prog 1off, Prog 2on, Prog 2off, Prog 3on, Prog 3off,  
Return to normal display

#### Notes on Programming:

a) All programs must be in consecutive order, i.e. program 1 must be before program 2 & program 2 before program 3. If the wrong order is programmed error messages will be displayed

b) If only 2 or less programs are required, for the remaining programs enter the same on & off times, e.g. Prog 3 on 8:00pm, off 8:00pm. This ensures the unwanted program is cancelled.

c) Programming past midnight is NOT allowed. An error message will be displayed. To overcome this the program needs to be split as per example-  
Desired program period - on 10:00pm off 7:00am  
make Prog 1 - on 12:00am off 7:00am  
make Prog 2 - on 7:00am off 7:00am  
make Prog 3 - on 10:00pm off 12:00am

Progs make up desired program period leaving prog 2 available for a program during the day.

d) if you try to input the off time before the on time an error message will be displayed. Press SET to continue.

#### Boost Function

Offers 3 options for on period duration outwith a program using the BOOST button.

Press once = 30mins

Press twice = 1 hour

Press three times = 2 hours

Press four times = Cancel function

Duration can be extended or cancelled by successive presses.

#### Off (Holiday) Function

Allows you to suspend programmes whilst still allowing the Boost function to be used using the OFF/ON button

Press once = Suspend programs

Press twice = Cancel

NOTE: This is NOT an override function for programs.

NOTE: BOOST button is still active.

#### Program Override Function

If during a program On time you wish to cancel the program simply press the BOOST button once.

NOTE: The program settings will not be affected & the next time this program is due, it will function as normal. Adjoining programs will also be cancelled.

#### Product Reset (return to default settings)

Switch off power to unit.

Hold in BOOST button whilst switching power back on.

1 displayed = press BOOST

2 displayed = press SET

3 displayed = press -

4 displayed = press +

5 displayed = press OFF/ON

All LCD segments flashing displayed (reset) = press SET to reprogram.

#### Keypad Lock

Press - & + together for 5 seconds to lock settings = display briefly shows L

NOTE: BOOST button is still active

NOTE: display shows L when other buttons pressed

Press - & + together for 5 seconds to unlock settings.

## Specification

Contact Rating: 16A Resistive, 240V a.c.  
Supply: 240V, 50-60Hz a.c.  
Fixing: Single patress - surface & flush mounting  
Resolution of Programs: 10 minutes  
Auto Summer/Winter Time Change: Yes  
Power Consumption: 10.3VA Maximum  
Live Parts Protection: This unit is totally protected by the enclosure  
Dirt & Moisture Protection: IP40  
Shock Protection: Class 1 (this must be connected to earth)  
Case Material: Polycarbonate, PT1 175  
Temperature Rating: T35  
Operating Temperature: 0°C to 35°C  
Memory Reserve (except Boost): 4 hours - when on power for previous 12 hours

#### Program Settings:

**PSD** - Max 3 On & 3 Off operations (Daily) - each day the same

**PSW** - Max 3 On & 3 Off operations (Mon-Fri) & Max 3 On & 3 Off alternative operations (Sat/Sun).

**PS24/7** - Max 3 On & 3 Off operations (7 days) each day independently programmable.

Boost Facility: User selectable

**PSB** - ½, 1 or 2 hours

**PSB MAXI** - 1, 3 or 5 hours

Type of Action: Type 1B

Control Pollution Category: Normal

If you have a problem or require any further information please contact our technical team on:  
**01475 745131**

**Sangamo Limited**  
Industrial Estate, Port Glasgow,  
Renfrewshire, PA14 5XG

Tel 01475 745131  
Fax: 01475 744567  
Email: [enquiries@sangamo.co.uk](mailto:enquiries@sangamo.co.uk)  
Web: [www.sangamo.co.uk](http://www.sangamo.co.uk)



#### SERVICE AND WARRANTY

Your product is not user serviceable. **PLEASE DO NOT TRY TO DISMANTLE THE UNIT.**

This product is guaranteed by your supplier for 5 years from the date of manufacture. If it should become defective please contact your installer or supplier for a replacement unit or visit [www.sangamo.co.uk/returns](http://www.sangamo.co.uk/returns)

This product must meet Waste Electronic and Electrical Equipment Regulations (WEEE) for suitable environmental recycling, recovery and/or disposal. End of life products should be handled in line with local regulations. Alternatively return end of life product to Sangamo for correct disposal.

#### CUSTOMER CARE POLICY

As part of Sangamo's continuous improvement program, the company operates a Customer Care policy. This means we welcome your comments and complaints, as it can help us to improve our services to you, our customer.

Due to our policy of continuous product improvement and development, the specifications in this guide may be subject to change without prior notice.