

# BRUSHLESS range from CROUZET

## 1 - Composition

This new product range is based on the 3-phase motor with **internal rotor**. The high-energy plasto-ferrite magnet is completely integral with the motor shaft. The chosen structure gives high dynamic performance : made possible by the low inertia of the rotor (unlike motors with external rotors, which have high inertia) .

The stator lamination stack acts as a heat dissipator for energy losses induced by the winding.

### ■ Motor principle :

With internal rotor,

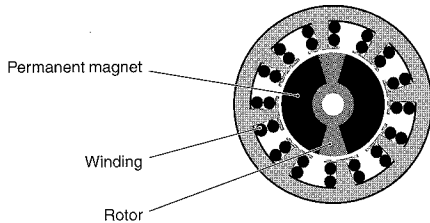

Both zamac flanges mounted on the stator lamination stack are fitted with a ball bearing, ensuring the motor will have a long service life.

### ■ Composition :

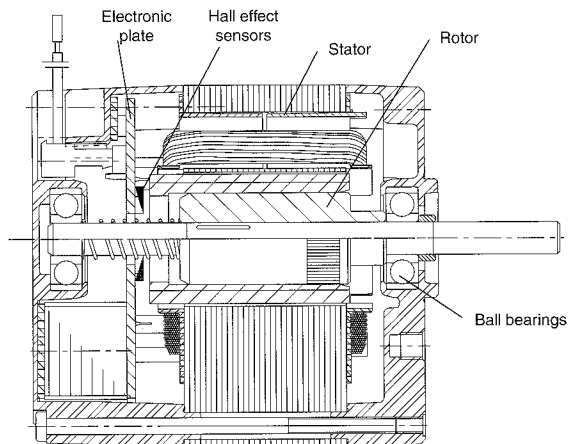

**The electronics required for operation are completely integrated in the motor.**

## 2 - Operating principle

The chosen architecture is based on a "3-phase" motor, with a 4-pole rotor.

■ **Sequencing** : the "3-phase" motor is wired as "delta". Three hall effect sensors are used to locate the position of the rotor.

The transistors conduct up to 120°

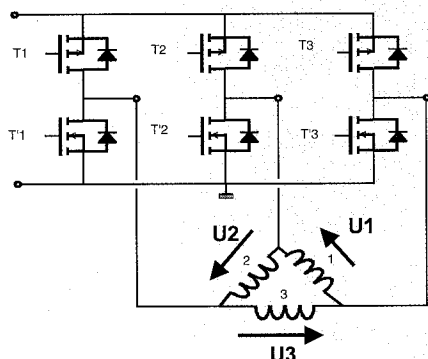

## Communication logic

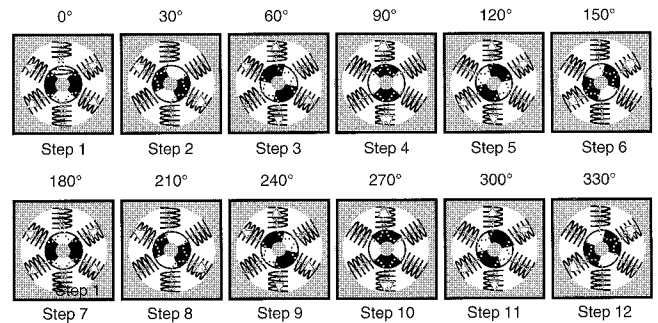
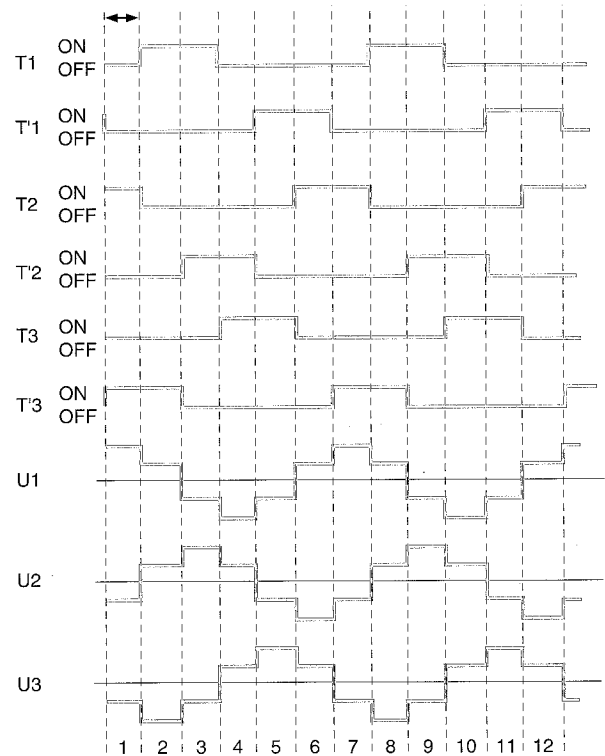

### ■ Resulting torque form

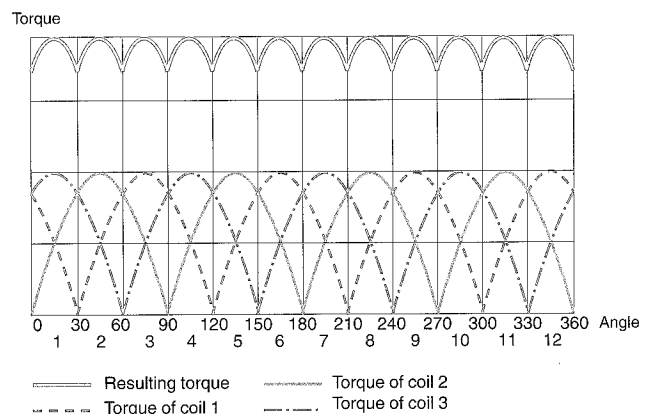

The "3-phase" motor provides the best possible compromise in terms of regularity of the resulting torque (low ripple percentage). As the electronics are completely integrated, all the sequencing is performed by the electronics inside the motor.

### 3 - Functions and inputs/outputs

The speed of the motors offered with integrated electronics can be controlled : by an analogue (0 - 10 volts), or digital (PWM : 15 kHz) speed signal.

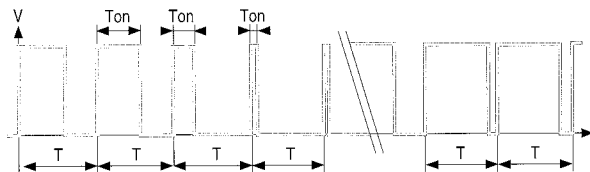

#### ■ Definition of PWM

T is constant, but Ton varies ; the Ton/T ratio is the cyclical ratio (as a %).

In this case, PWM is a control signal, converted by the electronics to set the speed.

- If the cyclical ratio is 0%, the speed is 0 rpm.
- If the cyclical ratio is 100%, the speed is N0 (no-load speed).
- If the cyclical ratio is 50%, the speed is N0/2 (half the no-load speed).

The voltage V is not significant (between 5 and 28 V), and does not affect the speed.

The PWM input is a digital input : it can be used by PLCs and micro-controllers.

#### ■ Motor protection :

The motors are completely protected during operation : by current limiting and thermal protection. During abnormal operation, in a machine or device : for example locking, the motor stops after approximately 3 seconds, (power stage off) and must be reinitialised via the On/Off input : **this is a failsafe system.**

#### ■ Inputs / Outputs :

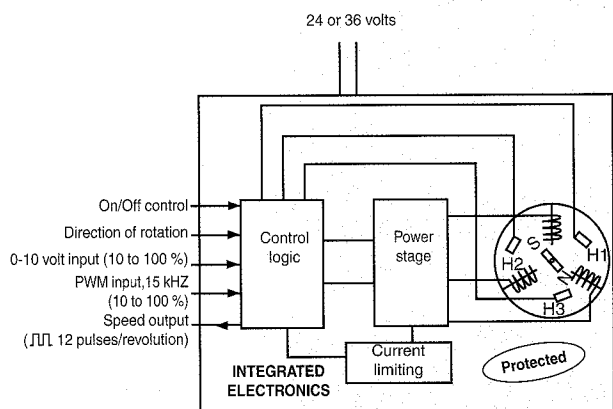

#### ■ Truth table for Inputs / Outputs :

On/Off	PWM	0-10 V	Direction	
0	x	x	x	motors off
1	1	0	0	reverse rotation
1	0	1	0	reverse rotation
1	1	1	0	unauthorised configuration
1	0	0	x	motors stopped
1	1	0	1	clockwise rotation
1	0	1	1	clockwise rotation
1	1	1	1	unauthorised configuration

X= don't care

1=Vih

0=Vil

#### ■ Speed regulation :

Two types of product with integrated electronics are offered for the whole range, both motors and geared motors.

**a) No speed regulation :** this option is offered for users who do not need to regulate speed in a closed loop, or who wish to reuse their own regulation electronics on an external card, to limit modifications to the architecture of their machine.

**Motors without integrated speed regulation :** no data feedback on action taken.

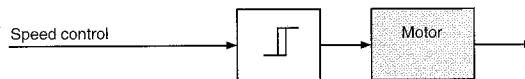

**b) With integrated speed regulation (eg : Part no. 80 030 003) see page 10.**

This integrated option can be used simply for a speed regulation function suitable for most applications. In effect : there is no longer any need to wire a motor to a card, no electromagnetic compatibility problems linked to wiring, hence reduced net cost!

#### Motor with integrated speed loop :

Hall effect sensors monitor the action taken, enabling the electronics to modify the command to achieve the desired effect.

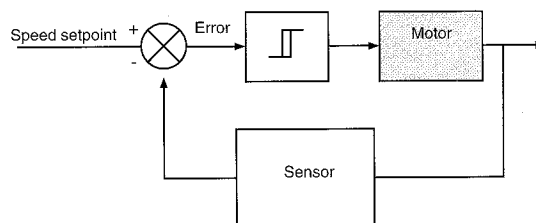

### 4- Safety

Crouzet BRUSHLESS DC motors are designed and manufactured to be integrated into devices or machines which meet, for example, the specifications of the machine standard : EN 60335-1 (IEC 335-1, "Safety of domestic electrical appliances").

The integration of Crouzet DC motors into devices or machines, should generally take account of the following motor characteristics :

- no earth connection
- "main isolation" motors (simple isolation)
- protection index : IP40
- isolation system class : B (120°C)

#### European low voltage directive 73/23/EEC of 19/02/73 :

CROUZET DC motors and geared motors are outside the field of application of this directive (LVD 73/23/EEC applies to voltages over 75 volts DC).

## 5 - Electromagnetic Compatibility (EMC) :

On request, Crouzet will provide the EMC characteristics of the various types of product.

**European directive 89/336/EEC of 03/05/89**, "electromagnetic compatibility" :

DC motors and geared motors which are components designed for professionals, to be incorporated in more complex devices, and not for end users, are excluded from the field of application of this directive.

**However, conscious of potential customer difficulties concerning problems linked to electromagnetic compatibility, Crouzet has designed its products to meet the requirements of the standards : for example EN 55011 Gr. 1 class B (medical) as well as EN 55022, class B (data processing) in terms of emitted electromagnetic interference, as well as standards linked to immunity : IEC 1000- 4 -2/3/4/5/6/8.**

### ■ Wiring precautions

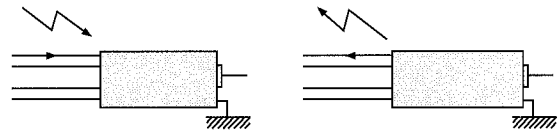

For EMC conformity :

- The motor must be connected to earth via its front flange.
- The length of the wires is 20 cm.

## 6- Electrical characteristics

	Symbol	Conditions Ta = -10 to 40 °C	Min.	Nominal	Max.	Units
<b>Power supply</b>						
Supply voltage	Vmot	Version 1	10.8	24	28	V
		Version 2	32.4	36	39.6	V
<b>Direction, on/off inputs</b>						
Logic level 1	Vih		3		Vmot	V
Logic level 0	Vil		-1		1.7	V
Current for logic level 1	Iih				0.5	mA
Current for logic level 0	Iil				0.05	mA
<b>0-10 V input</b>						
Voltage	Vma		-1		Vmot	V
Input impedance	Ze			10		kΩ
<b>PWM (Pulse width modulation) input</b>						
Logic level 1	Vih		3		28	V
Logic level 0	Vil		-1		1.7	V
Current for logic level 1	Iih				0.5	mA
Current for logic level 0	Iil				0.05	mA
PWM input frequency	Fin		13	15	17	kHz
<b>Encoder output</b>						
Voltage for level 0	Vol	Vih = 5 V, R pull up = 1.2 kΩ			0.4	V
Voltage for level 1	Voh				35	V
Current for level 0	Iol				5	mA
Current for level 1	Ioh				0.8	mA
Width of low level	Wle			320		μs
<b>Current limiting</b>						
Limit value	I <sub>max</sub>	Ta = 20 °C, electronics at ambient 20 °C			3	A
Derating	I <sub>dt</sub>			-23		mA/°C

## 7 - Connection diagrams

General precautions : see page 7, 8, 10.  
Connector marking : see page 10.

### ■ Simplified connection

This connection only requires a power supply ( 24 or 36 V, 3 A).  
Point 3 should not be connected.

This diagram can be further simplified by connecting input 7 directly to the power supply positive and input 6 either to the power supply positive or negative depending on the direction of rotation required.

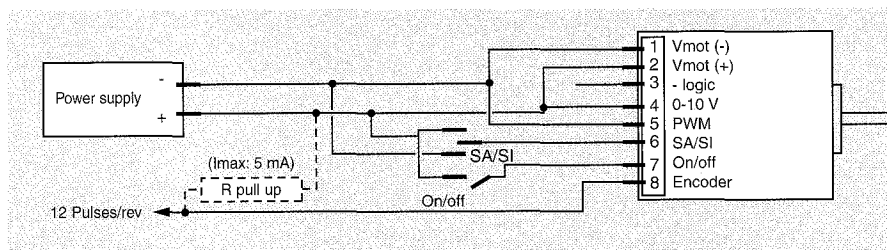

### ■ Adjusting the speed using a potentiometer

Point 3 should not be connected.

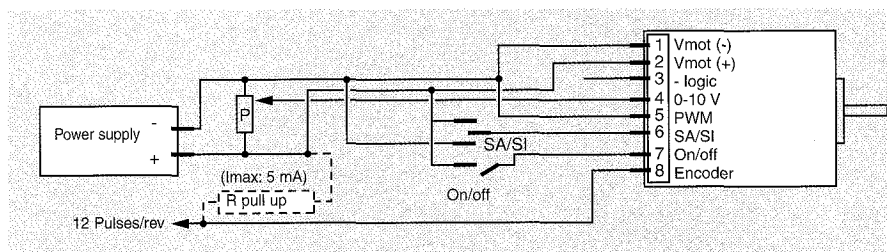

### ■ Using the 0-10 V input, with a separate power supply

This connection requires a power supply (24 or 36 V, 3 A) and a 0-10 V supply.

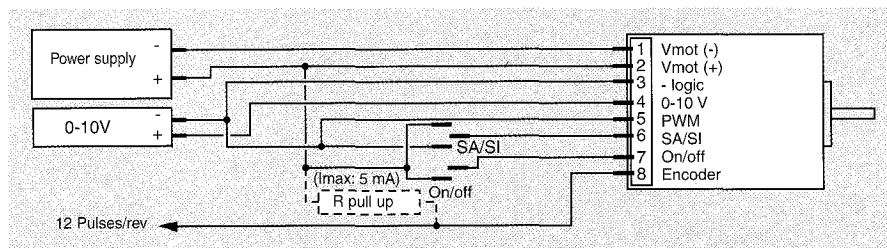

### ■ Using the PWM input

This connection requires a power supply (24 or 36 V, 3 A) and a supply with PWM and a frequency of 15 kHz.

