

LOC	DIST	REVISIONS			
		REV	DESCRIPTION	DATE	BY
AJ	16	A	REVISED PER EC OS14-0150-05	30AUG05	BM JL

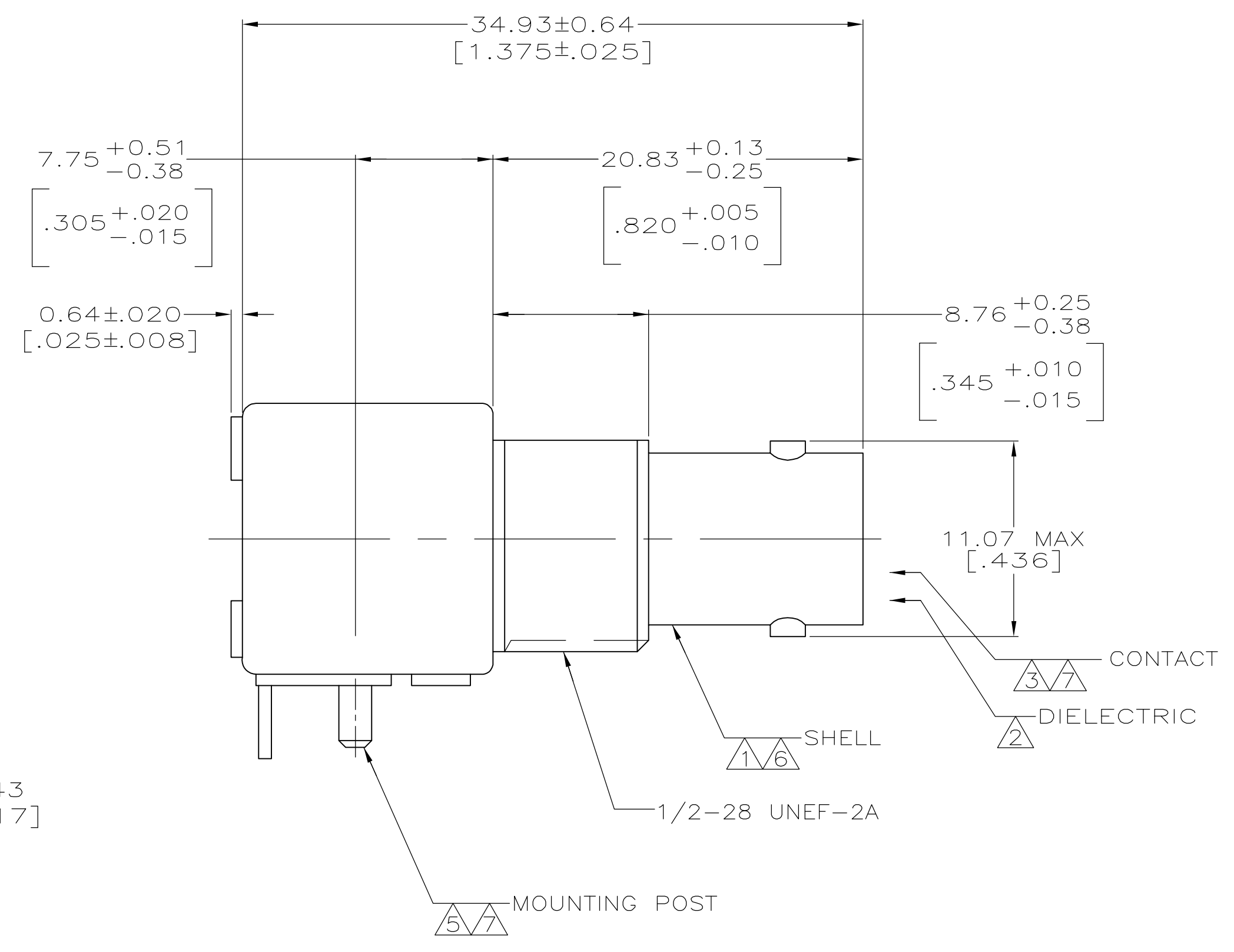

- ① ZINC PER QQ-Z-363.
- ② POLYMETHYLPENTENE PER ASTM-D-1238.
- ③ PHOSPHOR BRONZE PER QQ-B-750.
- ④ BRASS PER ASTM-B-453.
- ⑤ BRASS PER ASTM-B-16.
- ⑥ NICKEL PLATE PER QQ-N-290, 3.81 μm [.000150] MINIMUM THICK.
- ⑦ TIN PLATE PER ASTM-B-545, 3.81 μm [.000150] MINIMUM THICK.
- 8. SEE INSTRUCTION SHEET 408-2769.

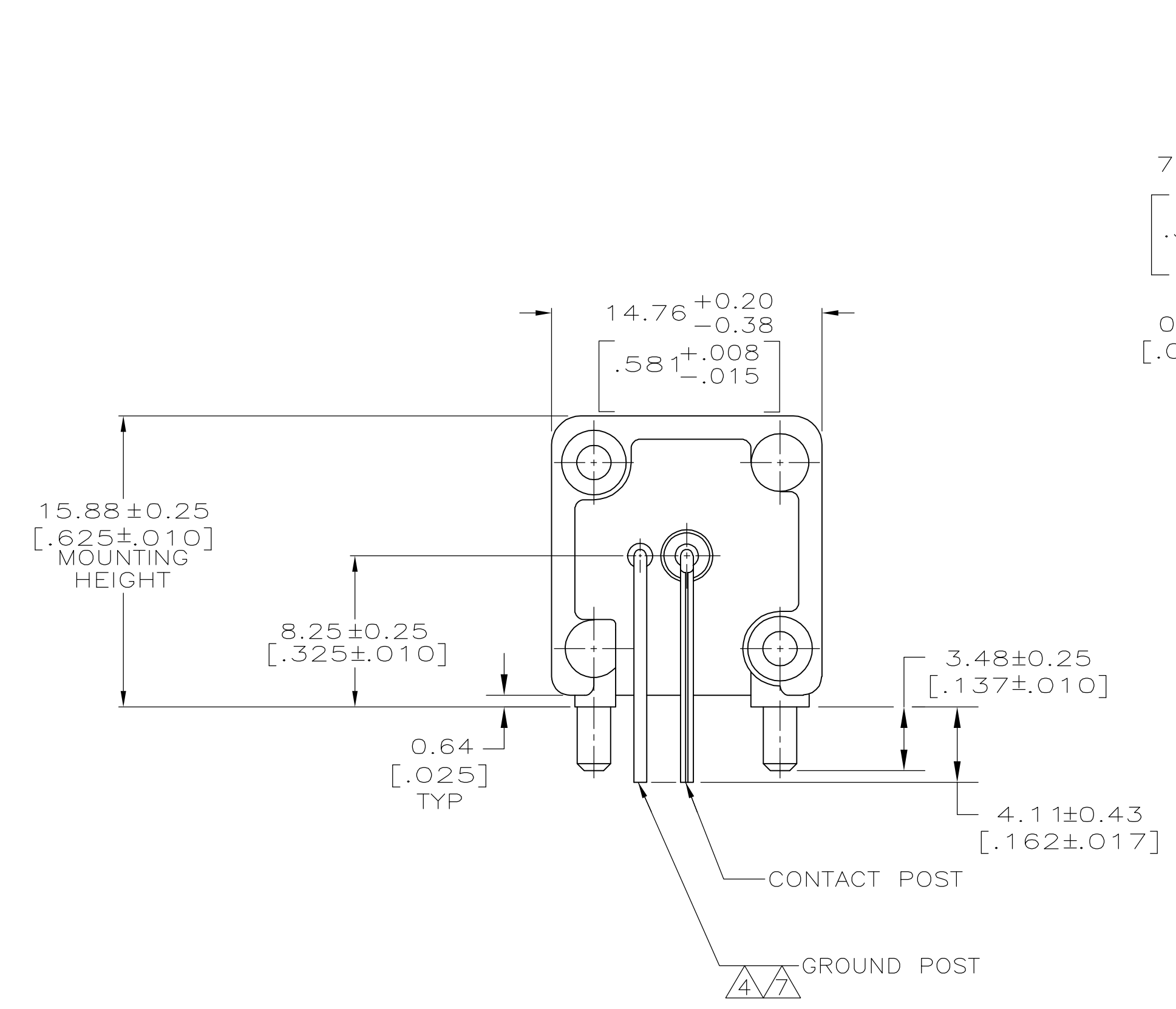
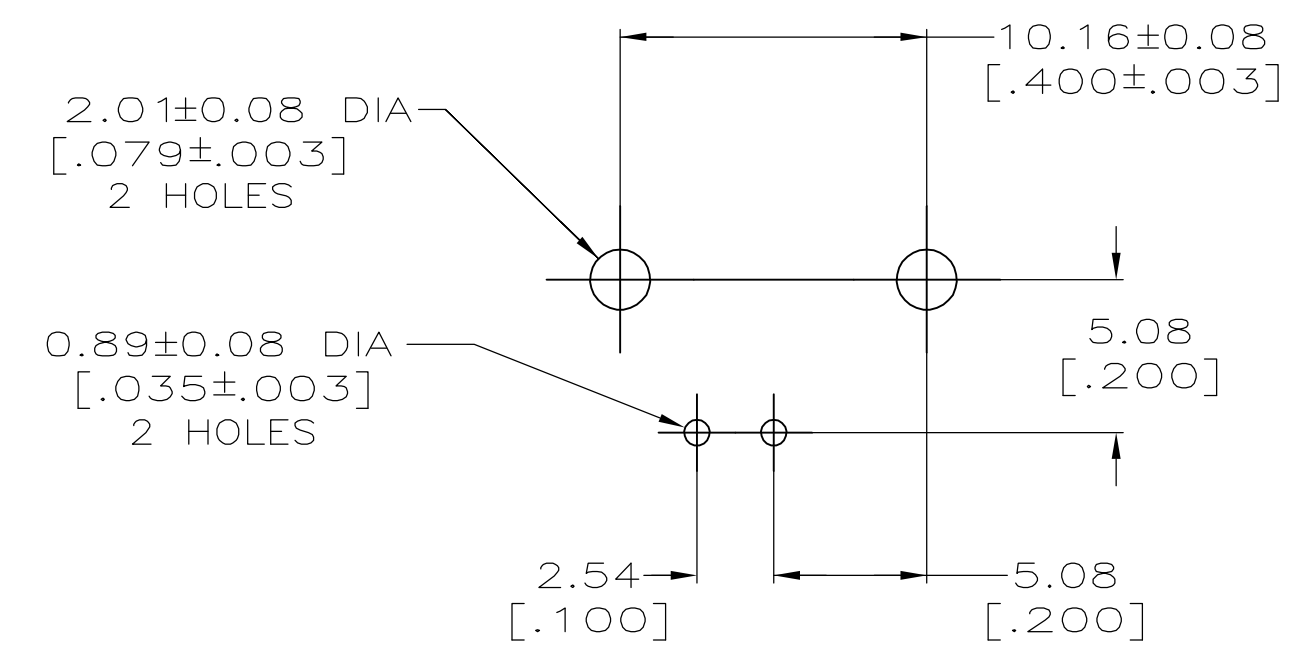
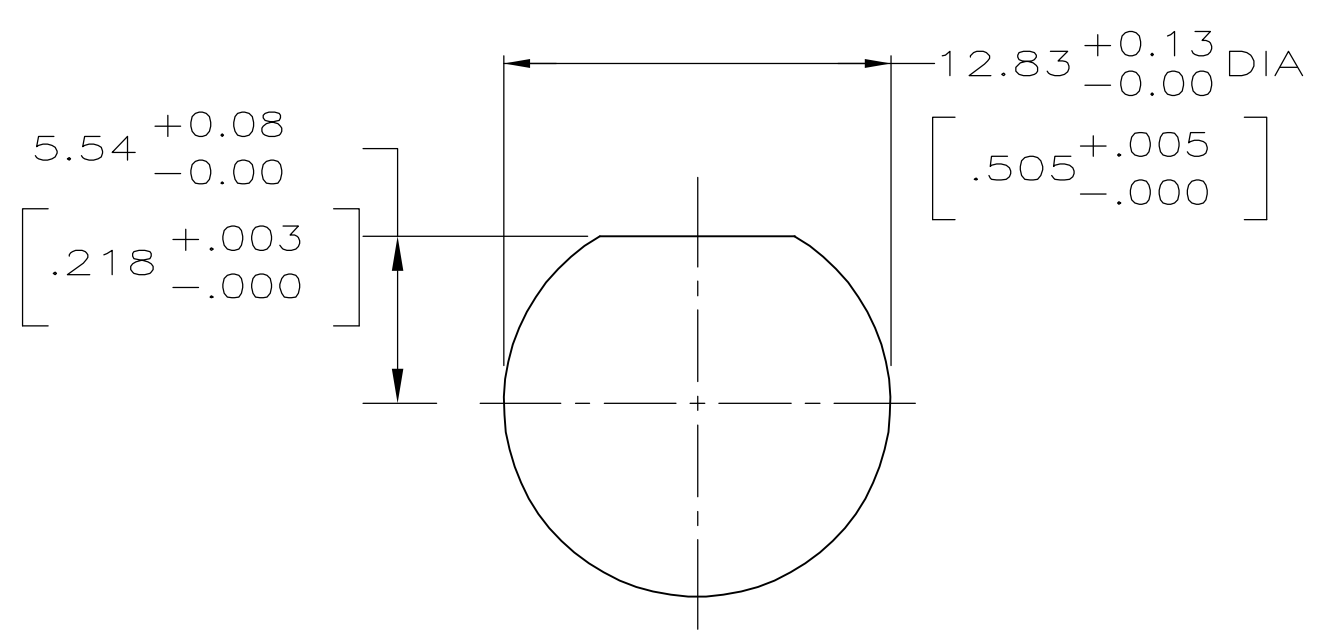

5227661-1
 PART NUMBER

THIS DRAWING IS A CONTROLLED DOCUMENT.		DWN J. ALCORTA - 26APR2005		Tyco Electronics Corporation Harrisburg, Pa 17105-3608	
DIMENSIONS: mm (INCHES)		CHK J. HAVENER - 26APR2005		APPRO J. LIPPERT - 26APR2005	NAME
TOLERANCES UNLESS OTHERWISE SPECIFIED:		PRODUCT SPEC 108-12078		APPLICATION SPEC	RESTRICTED TO
0 PLC ± - 1 PLC ± - 2 PLC ± 0.05 [.002] 3 PLC ± - 4 PLC ± - ANGLES ± - FINISH		SIZE A1		CAGE CODE 00779	DRAWING NO 5227661
MATERIAL		WEIGHT		CUSTOMER DRAWING	
		SCALE 4:1		SHEET 1 OF 1 REV A	