

from Allen-Bradley

Ordering Information

Drive Ratings		Part Number		
Input Voltage	Output kW (HP)	Drive Catalog No. ¹ (Series B)	1 Phase Filter No. ²	3 Phase Filter No. ²
100-120	0.2 (0.25)	161S-DA01NP_	161S-RFD-10-B	NA
100-120	0.4 (0.5)	161S-DA02NP_	161S-RFD-10-B	NA
100-120	0.75 (1.0)	161S-DA04NP_	161S-RFD-16-C	NA
200-240	0.2 (0.25)	161S-AA01NP_	161S-RFA-7-A	161-RFA-4-A
200-240	0.4 (0.5)	161S-AA02NP_	161S-RFA-7-A	161-RFA-4-A
200-240	0.55 (0.75)	161S-AA03NP_	161S-RFA-7-A	161-RFA-4-A
200-240	0.75 (1.0)	161S-AA04NP_	161S-RFA-12-B	161-RFA-7-B
200-240	1.1 (1.5)	161S-AA05NP_	161S-RFA-12-B	161-RFA-7-B
200-240	1.5 (2.0)	161S-AA07NP_	161S-RFA-22-C	161-RFA-20-C
200-240	2.2 (3.0)	161S-AA10NP_	161S-RFA-22-C	161-RFA-20-C
200-240	3.7 (5.0)	161S-AA15NP_	NA	161-RFA-20-C

¹"K" for 50 Hz default setting or "U" for 60 Hz default setting to complete part number.
e.g. 161S-AA04NPU is 200-240 input voltage, 0.75 kW (1.0 hp) with 60 Hz factory default settings.

²Filters are only used to assist in meeting "CE" requirements with Series B 161 Drives

● Wide Range of Adjustable Features

● Small Package Size

● Reliable Screw Terminals

● Fixed Program Keypad

● Configurable I/O



For more information, please contact your local Allen-Bradley Distributor or Rockwell Automation sales office.

Publication 161-PP001B-EN-P — November 2000
Supersedes December 1999



Allen-Bradley

Bulletin 161 AC Drives
The BIG value small drive



Bringing Together Leading Brands in Industrial Automation

The big value small drive

Allen-Bradley Ideal for installation in machines and control panels, the 161 AC Drive provides exceptional value for a wide range of applications, all with the pure quality and reliability you'd expect from the world's leading drive manufacturer.

Versatile Control

Analog, PID and preset speed control combined with five programmable inputs and four programmable outputs, make the 161 AC Drive an ideal choice for the control of 3-phase induction motors.

Easy to Use

With a fixed program keypad with built-in speed pot, 161 AC Drives are compact, easy to install and have a small adjustment set for ease of use.

Wide Range

The 161 AC Drive is available for control of 230V three-phase induction motors with the following output power and input voltage ratings:

- 0.2 to 0.75 kW (0.25 to 1 hp), 100-120V single-phase input
- 0.2 to 2.2 kW (0.25 to 3 hp), 200-240V single- or three-phase input
- 3.7 kW (5 hp), 200-240V three-phase input



Input/Output Configuration

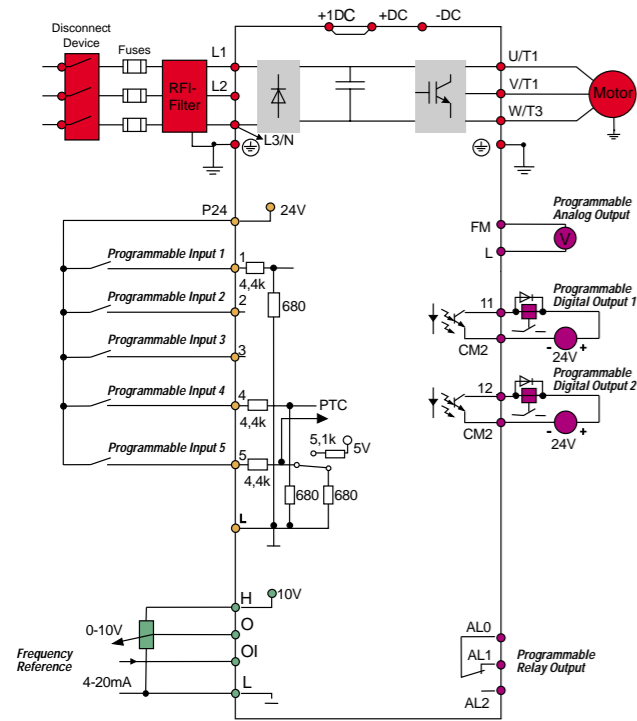

Power Terminals

- Power input/output
- DC Bus Terminals

5 Programmable Inputs

- Forward run
- Reverse run
- Pre-set frequencies
- Frequency command select
- 2nd accel/decel time
- Enable
- External Fault
- Unintentional start protection
- Parameter protection
- Reset
- Jog
- PTC input
- Three-wire start
- Three-wire stop

4 Programmable Outputs¹

- One Analog Output
 - ▼ Output frequency
 - ▼ Output current
- Two Digital Outputs
 - ▼ Running
 - ▼ At frequency
 - ▼ Above frequency
 - ▼ Motor overload
 - ▼ PID error
 - ▼ Fault
- One Relay Output
 - ▼ Ready
 - ▼ Fault

Frequency Reference

- 0-10V
- 4-20mA

Series	Bulletin 161							
Type	-A01	-A02	-A03	-A04	-A05	-A07	-A10	-A15
Drive rating kW (HP)	0.2 (.25)	0.4 (.5)	0.55 (.75)	0.75 (1)	1.1 (1.5)	1.5 (2)	2.2 (3)	3.7 (5)
115V Input rated current (A)	5.5	10.0	N/A	16.0	N/A	N/A	N/A	N/A
230V 1Φ Input rated current (A)	3.1	5.8	6.7	9.0	11.2	16.0	22.5	N/A
230V 3Φ Input rated current (A)	1.8	3.4	3.9	5.2	6.5	9.3	13.0	20.0
Output rated current (A)	1.4	2.6	3.0	4.0	5.0	7.1	10.0	15.9
Input voltage (V)	200V – 10% to 240V + 5%; 100V -5% to 120V + 5%, 50/60 Hz ± 5%							
Output voltage	3 Φ adjustable from 0 to 230V							
Enclosure type	IP20							
PWM carrier frequency	0.5 – 16kHz							
V/F characteristics	Programmable V/Hz ratio, V/Hz control (constant torque, variable torque)							
Type of control	Voltage-driven, PWM sine weighted, IGBT-Power module							
Output frequency	0.5 – 360Hz							
Accuracy of frequency command	Digital: ± 0.01% of max. frequency, Analog: ± 0.2% of maximum frequency							
Frequency resolution	Digital: 0.1%, Analog: 0.01% of maximum frequency							
Overload capacity	150% for 60 secs							
Starting torque	Minimum 150% at frequencies > 3 Hz							
Inherent Braking Torque	A01...A04: 100% A05...A07: 70% A10...A015: 20% (Approximate, actual values depend on motor characteristics)							
DC brake/hold	DC injection at 10 Hz or below with programmable hold voltage and hold time							
Analog inputs	0–10V, input impedance 10KΩ; 4–20 mA, input impedance 250KΩ; PTC input							
Digital inputs	5 programmable level-triggered inputs, 24V PNP logic, NO contacts or NC contacts							
Analog outputs	1 programmable analog output. 0–10V, 1mA, Accuracy: ± 5% for frequency, ± 20% for current.							
Digital outputs	2 open collector outputs. 27VDC, 50mA							
Protection functions	Overcurrent, overvoltage, under-voltage, electronic motor overload protection, overtemperature, ground fault at start, etc.							
Other functions	15 preset speeds, PID control, unintentional start protection, RS422 serial interface, 3 skip frequencies etc.							
Ambient temperature	-10 – +40°C (up to +50°C by removing top cover, reducing carrier frequency to 2 kHz, and derating output current by 20%).							
Relative humidity	20 –90% relative humidity, no condensation.							
Vibration/shock	Vibration: 0.6G operational, Shock: 10.0G operational							
Max. installation altitude	1060m (3000 ft.) above sea level							
Standards	LV: EN50178 EMC: 61800-3 external filter required							



Dimensions (Series B)

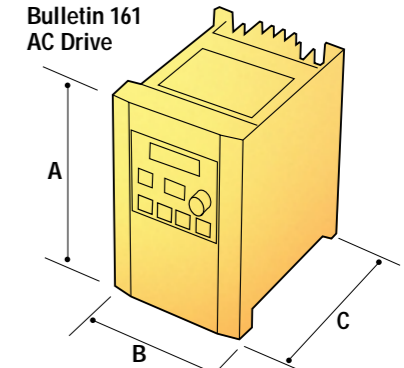

RATINGS		161S Part Number	A	B	C
100–120	0.2 (0.25)	DA01NP	130(5.12)	128(5.04)	117(4.61)
100–120	0.4 (0.5)	DA02NP	130(5.12)	128(5.04)	117(4.61)
100–120	0.75 (1.0)	DA04NP	180(7.09)	128(5.04)	117(4.61)
200–240	0.2 (0.25)	AA01NP	120(4.72)	84(3.31)	100(3.94)
200–240	0.4 (0.5)	AA02NP	120(4.72)	84(3.31)	114(4.49)
200–240	0.55 (0.75)	AA03NP	120(4.72)	84(3.31)	114(4.49)
200–240	0.75 (1.0)	AA04NP	130(5.12)	114(4.49)	136(5.35)
200–240	1.1 (1.5)	AA05NP	130(5.12)	114(4.49)	136(5.35)
200–240	1.5 (2.0)	AA07NP	180(7.09)	140(5.51)	160(6.30)
200–240	2.2 (3.0)	AA10NP	180(7.09)	140(5.51)	171(6.73)
200–240	3.7 (5.0)	AA15NP	180(7.09)	140(5.51)	171(6.73)

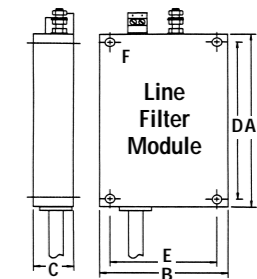

Line Filter Module ¹	A	B	C	D	E	F
161S-RFD-10-B	130(5.12)	128(5.04)	27(1.06)	118(4.65)	119(4.69)	4 x 6(24)
161S-RFD-16-C	180(7.09)	128(5.04)	27(1.06)	168(6.61)	119(4.69)	4 x 6(24)
161S-RFA-7-A	120(4.72)	80(3.15)	25(.98)	110(4.33)	67(2.64)	2 x 6(24)
161S-RFA-12-B	130(5.12)	110(4.33)	27(1.06)	118(4.65)	98(3.86)	4 x 6(24)
161S-RFA-22-C	180(7.09)	140(5.51)	29(1.14)	168(6.61)	128(5.04)	4 x 6(24)
161-RFA-4-A	120(4.72)	80(3.15)	25(.98)	110(4.33)	67(2.64)	2 x 6(24)
161-RFA-7-B	130(5.12)	110(4.33)	27(1.06)	118(4.65)	98(3.86)	4 x 6(24)
161-RFA-20-C	180(7.09)	140(5.51)	29(1.14)	168(6.61)	128(5.04)	4 x 6(24)

¹Filters are only used to assist in meeting "CE" requirements with Series B 161 Drives