

Customer Information Sheet

DRAWING No.: M80-400000F1-XX-XXX-00-000

SHEET 3 OF 4

IF IN DOUBT - ASK

(C)

NOT TO SCALE

THIRD ANGLE PROJECTION

ALL DIMENSIONS IN mm

SPECIFICATIONS:

MATERIAL:

MOULDING: GLASS FILLED PPS, UL94V-0, BLACK
 POWER & COAX CONTACT:
 BODY = COPPER ALLOY
 INNER CONTACT, LATCHING COLLAR = BERYLLIUM COPPER
 INSULATOR = PTFE
 JACKSCREW, CIRCLIP: STAINLESS STEEL
 FINISH:
 POWER & COAX CONTACT
 BODY, SLEEVE, INNER CONTACT = GOLD
 LATCHING COLLAR: = NICKEL

ELECTRICAL:

WORKING VOLTAGE = 120V AC/DC
 VOLTAGE PROOF = 360V AC/DC
 INSULATION RESISTANCE = 100MΩ MIN
 POWER CONTACT:
 CONTACT RESISTANCE = 6mΩ MAX
 CURRENT RATING = M80-325 20A MAX 12AWG
 M80-326 15A MAX 14AWG
 M80-327 10A MAX 16AWG
 CONTACT AS SPECIFIED
 COAX CONTACT:
 FREQUENCY RANGE = 6GHz
 IMPEDANCE = 50 Ω
 V.S.W.R = 1.05 + (0.04 x FREQUENCY) GHz MAX
 CONTACT RESISTANCE 6 mΩ MAX
 INSULATION RESISTANCE = 10⁶MΩ @250V AC
 OPERATING VOLTAGE = 180V AC @ 500mA
 MAXIMUM VOLTAGE = 1000V AC

MECHANICAL:

DURABILITY = 500 OPERATIONS
 POWER & COAX CONTACT:
 INSERTION FORCE = 5N MAX
 WITHDRAWAL FORCE = 0.5N MIN
 ENVIRONMENTAL:
 TEMPERATURE RANGE = -55°C TO +125°C
 PACKING:
 BAG
 FOR COMPLETE SPECIFICATION SEE COMPONENT SPECIFICATION C005XX (LATEST ISSUE)

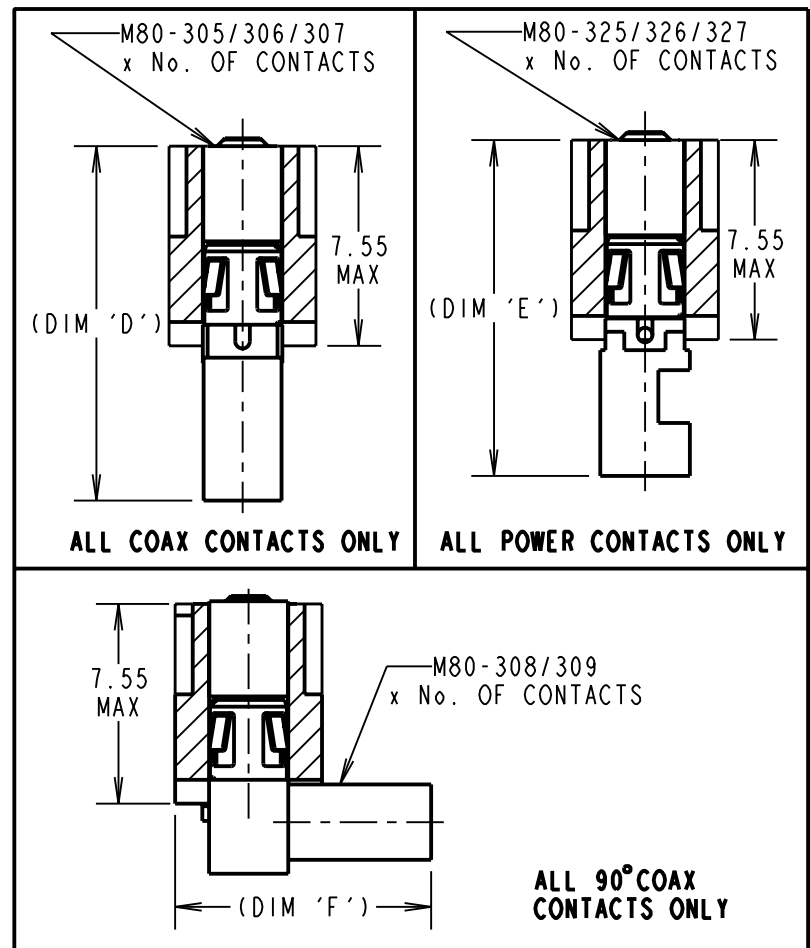
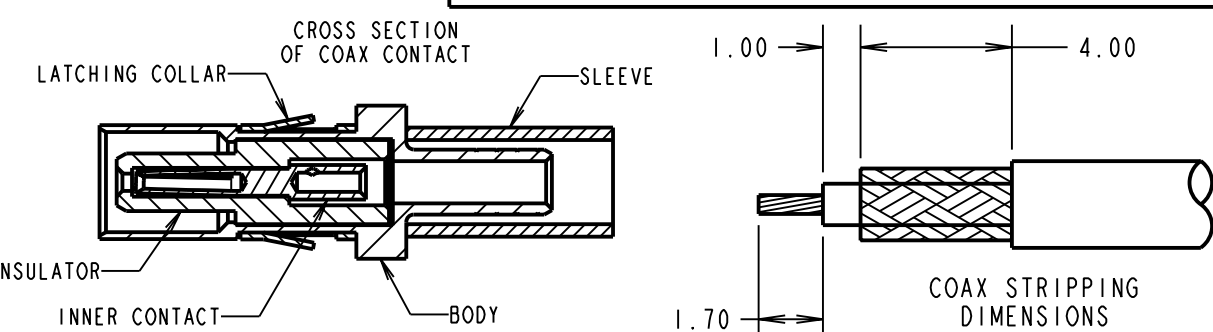
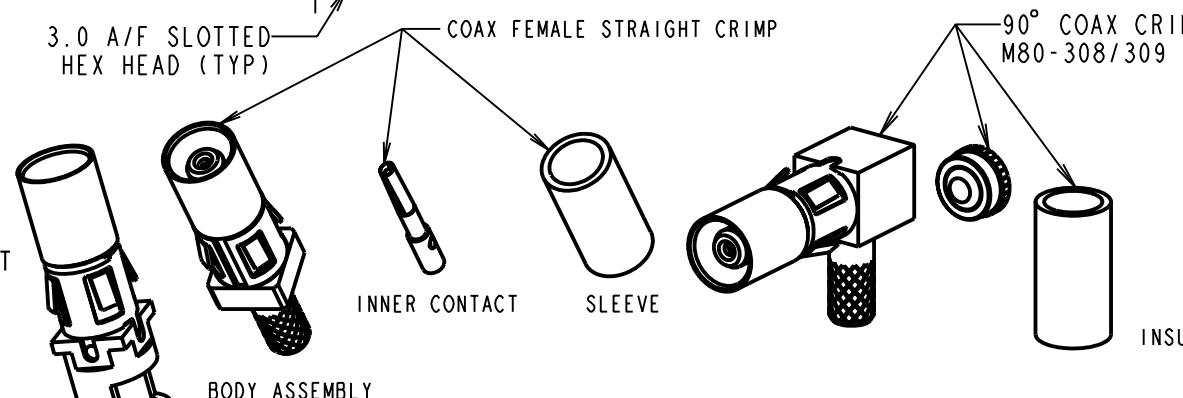
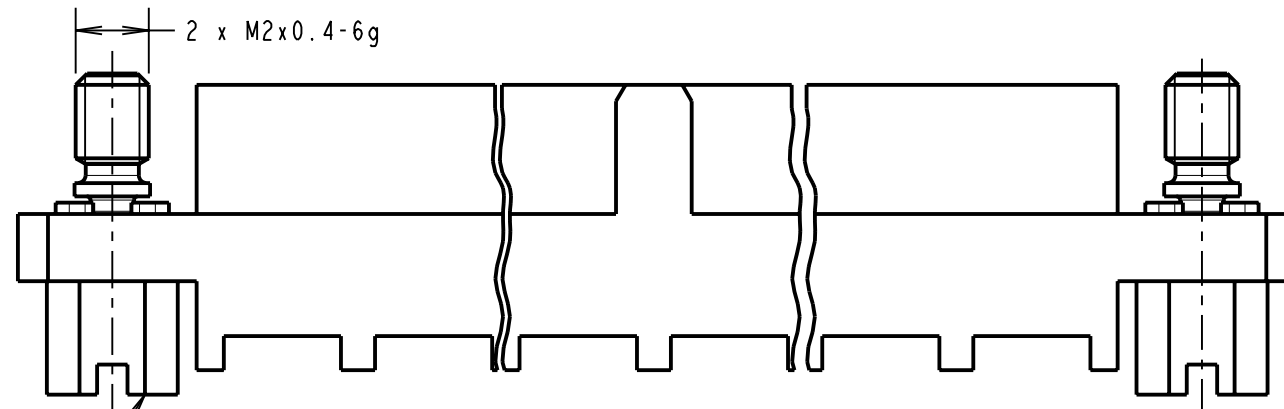
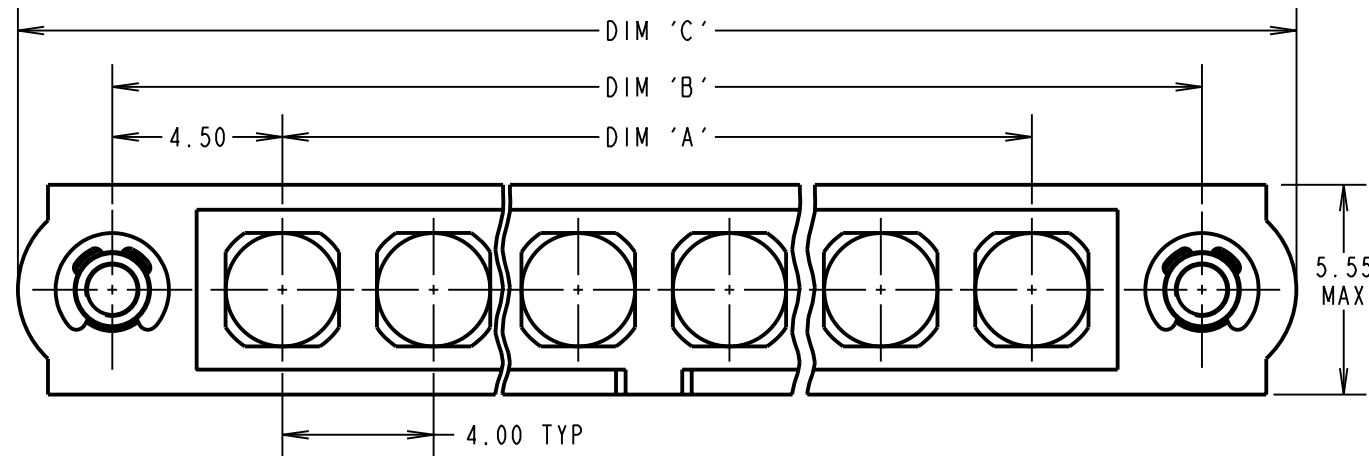

NOTES:

- CONNECTORS ARE SUPPLIED WITH CONTACTS LOOSE.
- COAX CONTACT IS SUPPLIED AS A KIT OF PARTS: BODY, INSULATOR AND LATCHING COLLAR ARE PRE-ASSEMBLED AND SLEEVE AND INNER CONTACT ARE SEPARATE.
- FOR EXTRA COAX CONTACTS, USE PART NUMBER M80-305/306/307/308/309 FOR EXTRA POWER CONTACTS, USE PART NUMBER M80-325/326/327
- RECOMMENDED HAND CRIMP TOOL FOR COAX INNER CONTACT = Z80-292 WITH POSITIONER Z80-291 AND RECOMMENDED HAND CRIMP TOOL AND DIE SET FOR COAX SLEEVE = Z80-293.
- POWER AND COAX CONTACT EXTRACTION TOOL = Z80-290
- POWER CONTACT WIRE, STRIP BY 5.00mm MINIMUM
- INSTRUCTION SHEETS ARE AVAILABLE.
- FOR EXAMPLE OF ALL COAX SPECIAL CONTACTS ORDER CODE SEE EXAMPLE 1 IN TABLE
- FOR EXAMPLE OF ALL POWER SPECIAL CONTACTS ORDER CODE SEE EXAMPLE 2 IN TABLE.

DIMENSION	CALCULATION
DIM 'A'	4 x No. OF CONTACTS - 4.00
DIM 'B'	4 x No. OF CONTACTS + 5.00
DIM 'C'	4 x No. OF CONTACTS + 10.00
DIM 'D'	M80-305/306/307=13.4mm
DIM 'E'	M80-325/326/327=12.7mm
DIM 'F'	M80-308/309 = 9.7mm
EXAMPLE 1: CONNECTOR WITH 08 COAX CONTACTS, M80-400000F1-08-305-00-000 DIM 'A' = 28.00mm, DIM 'B' = 37.00mm, DIM 'C' = 42.00mm DIM 'D' = 13.4mm	
EXAMPLE 2: CONNECTOR WITH 10 POWER CONTACTS, M80-400000F1-10-325-00-000 DIM 'A' = 36.00mm, DIM 'B' = 45.00mm, DIM 'C' = 50.00mm DIM 'E' = 12.7mm	

ORDER CODE:
M80-400000F1-XX-XXX-00-000

TOTAL No. OF CONTACTS _____
 02 TO 12

SPECIAL CONTACTS _____
 305 = COAX CONTACT CRIMP 2.0mm M80-305
 306 = COAX CONTACT CRIMP 2.4mm M80-306
 307 = COAX CONTACT CRIMP 2.7mm M80-307
 308 = 90° COAX CONTACT CRIMP 2.0mm M80-308
 309 = 90° COAX CONTACT CRIMP 2.7mm M80-309
 325 = POWER CONTACT SOLDER 12AWG M80-325
 326 = POWER CONTACT SOLDER 14AWG M80-326
 327 = POWER CONTACT SOLDER 16AWG M80-327

HARWIN

HARWIN USA TEL: 603 893 5376 FAX: 603 893 5396 mis@harwin.com	HARWIN Europe (UK) TEL: 023 9231 4545 FAX: 023 9231 4590 mis@harwin.co.uk	HARWIN Asia TEL: +65 6 779 4909 FAX: +65 6 779 3868 mis@harwin.com.sg
--	--	--

THIS DRAWING AND ANY INFORMATION OR DESCRIPTIVE MATTER SET OUT HEREON ARE CONFIDENTIAL AND COPYRIGHT PROPERTY OF THE HARWIN GROUP AND MUST NOT BE DISCLOSED, LOANED, COPIED OR USED FOR MANUFACTURING, TENDERING OR FOR ANY OTHER PURPOSE WITHOUT THEIR WRITTEN PERMISSION.

TOLERANCES
 X. = ±1mm
 X.X = ±0.25mm
 X.XX = ±0.10mm
 X.XXX = ±0.01mm
 ANGLES = ±5°
 UNLESS STATED

MATERIAL: SEE ABOVE
 FINISH: SEE ABOVE
 S/AREA: mm²

TITLE: JACKSCREW DATAMATE MIXED TECHNOLOGY FEMALE ASSEMBLY
 DRAWING NUMBER: **M80-400000F1-XX-XXX-00-000**
 SHT 3 OF 4

RA	B	06.10.09	10517
NAME	ISS.	DATE	C/NOTE
APPROVED:		R.ADDE	
CHECKED:		M.G.PLESTED	
DRAWN:		R.ADDE	
CUSTOMER REF.:			
ASSEMBLY DRG:			

Customer Information Sheet

DRAWING No.: M80-400000F1-XX-XXX-00-000

SHEET 4 OF 4

IF IN DOUBT - ASK

(C)

NOT TO SCALE

THIRD ANGLE PROJECTION

ALL DIMENSIONS IN mm

SPECIFICATIONS:

MATERIAL:
 MOULDING: GLASS FILLED PPS, UL94V-0, BLACK
POWER & COAX CONTACT:
 BODY = COPPER ALLOY
 INNER CONTACT = BERYLLIUM COPPER
 INSULATOR = PTFE
JACKSCREW, CIRCLIP: STAINLESS STEEL
FINISH:
 POWER & COAX CONTACT
 BODY, SLEEVE, INNER CONTACT = GOLD
ELECTRICAL:
 WORKING VOLTAGE = 120V AC/DC
 VOLTAGE PROOF = 360V AC/DC
 INSULATION RESISTANCE = 100MΩ MIN
POWER CONTACT:
 CONTACT RESISTANCE = 6mΩ MAX
 CURRENT RATING = 20A MAX
COAX CONTACT:
 FREQUENCY RANGE = 6GHz
 IMPEDANCE = 50 Ω
 V.S.W.R = 1.05 + (0.04 x FREQUENCY) GHz MAX
 CONTACT RESISTANCE 6 mΩ MAX
 INSULATION RESISTANCE = 10⁶MΩ @250V AC
 OPERATING VOLTAGE = 180V AC @ 500mA
 MAXIMUM VOLTAGE = 1000V AC
MECHANICAL:
 DURABILITY = 500 OPERATIONS
POWER & COAX CONTACT:
 INSERTION FORCE = 5N MAX
 WITHDRAWAL FORCE = 0.5N MIN
ENVIRONMENTAL:
 TEMPERATURE RANGE = -55°C TO +125°C
PACKING:
 TUBE
 FOR COMPLETE SPECIFICATION SEE COMPONENT SPECIFICATION C005XX (LATEST ISSUE)

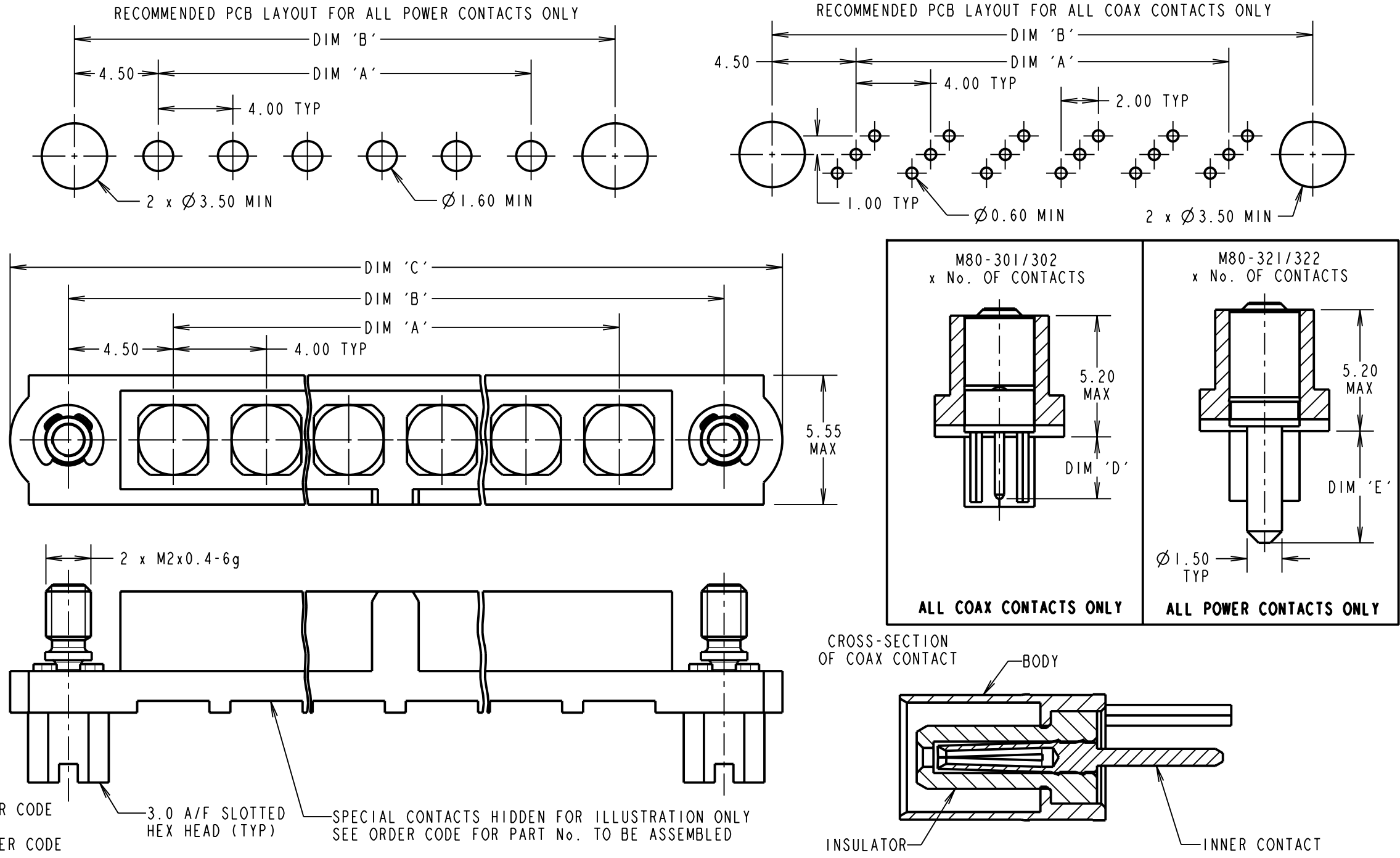

- NOTES:**
 1. FOR EXAMPLE OF ALL COAX SPECIAL CONTACTS ORDER CODE SEE EXAMPLE 1 IN TABLE
 2. FOR EXAMPLE OF ALL POWER SPECIAL CONTACTS ORDER CODE SEE EXAMPLE 2 IN TABLE.

DIMENSION	CALCULATION
DIM 'A'	4 x No. OF CONTACTS - 4.00
DIM 'B'	4 x No. OF CONTACTS + 5.00
DIM 'C'	4 x No. OF CONTACTS + 10.00
DIM 'D'	M80-301 = 3.00mm, M80-302 = 4.50mm
DIM 'E'	M80-321 = 3.50mm, M80-322 = 5.00mm

EXAMPLE 1: CONNECTOR WITH 08 COAX CONTACTS,
 M80-400000F1-08-301-00-000
 DIM 'A' = 28.00mm, DIM 'B' = 37.00mm, DIM 'C' = 42.00mm
 DIM 'D' = 3.00mm

EXAMPLE 2: CONNECTOR WITH 10 POWER CONTACTS,
 M80-400000F1-10-321-00-000
 DIM 'A' = 36.00mm, DIM 'B' = 45.00mm, DIM 'C' = 50.00mm
 DIM 'E' = 3.50mm

ORDER CODE:(PC TAIL CONTACTS ONLY)
M80-400000F1-XX-XXX-00-000

TOTAL No. OF CONTACTS
 02 TO 12

SPECIAL CONTACTS
 301 = COAX CONTACT PC TAIL 3.0mm M80-301
 302 = COAX CONTACT PC TAIL 4.5mm M80-302
 321 = POWER CONTACT PC TAIL 3.5mm M80-321
 322 = POWER CONTACT PC TAIL 5.0mm M80-322

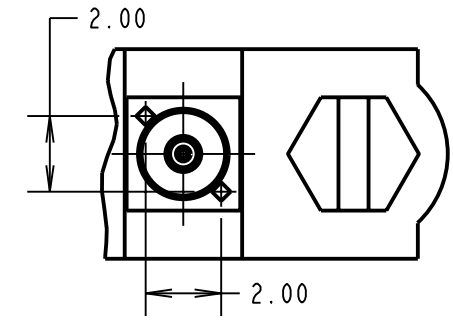

HARWIN

HARWIN USA
 TEL: 603 893 5376
 FAX: 603 893 5396
 mis@harwin.com

HARWIN Europe (UK)
 TEL: 023 9231 4545
 FAX: 023 9231 4590
 mis@harwin.co.uk

HARWIN Asia
 TEL: +65 6 779 4909
 FAX: +65 6 779 3868
 mis@harwin.com.sg

THIS DRAWING AND ANY INFORMATION OR DESCRIPTIVE MATTER SET OUT HEREON ARE CONFIDENTIAL AND COPYRIGHT PROPERTY OF THE HARWIN GROUP AND MUST NOT BE DISCLOSED, LOANED, COPIED OR USED FOR MANUFACTURING, TENDERING OR FOR ANY OTHER PURPOSE WITHOUT THEIR WRITTEN PERMISSION.

TOLERANCES
 X. = ±1mm
 X.X = ±0.25mm
 X.XX = ±0.10mm
 X.XXX = ±0.01mm
 ANGLES = ±5°
 UNLESS STATED

MATERIAL:
 SEE ABOVE

FINISH:
 SEE ABOVE

S/AREA:
 mm²

TITLE: JACKSCREW DATAMATE MIXED TECHNOLOGY FEMALE ASSEMBLY

DRAWING NUMBER: M80-400000F1-XX-XXX-00-000

ASSEMBLY DRG:

RA B 06.10.09 10517
 NAME ISS. DATE C/NOTE
 APPROVED: R.ADDE
 CHECKED: M.G.PLESTED
 DRAWN: R.ADDE
 CUSTOMER REF.:
 SHT 4 OF 4