

DIE ASSEMBLY	PRODUCT
91902-1	50-Ohm C, HN, N, and TNC COAXICON* Connectors
91907-[ ]	ARINC Size 8 Triaxial Contacts
91908-1	SMA Series 50-Ohm RF Connectors
91909-1	50-Ohm C, HN, N, and TNC COAXICON Connectors
91910-[ ]	50-Ohm BNC COAXICON Connectors
1424050-1	50-Ohm BNC Connectors

Figure 1

## 1. INTRODUCTION

The SDE crimping die assemblies listed in Figure 1 are designed to crimp the products also listed in Figure 1. The die assembly must be installed into PRO-CRIMPER\* III Frame Assembly 354940-1. Refer to instruction sheet 408-9930 for information on the hand tool frame.

**NOTE**  Dimensions in this instruction sheet are in metric units [with U.S. customary units in brackets]. Figures are not drawn to scale.

Reasons for reissue of this instruction sheet are provided in Section 8, REVISION SUMMARY.

## 2. DESCRIPTION

Each four-piece die assembly consists of two indenter dies and two anvil dies. When closed, the die assembly forms two or three crimping chambers. The larger crimping chambers crimp the ferrule of the connector onto the coaxial cable, and the smaller crimping chamber crimps the center contact onto the center conductor of the coaxial cable. Each set of dies is held in the tool frame by two pins and a screw.

## 3. INSTALLATION AND REMOVAL

1. Close the tool handles until the ratchet releases, then allow the tool handles to open fully.

**NOTE**  The ratchet has detents with audible “clicks” as the handles are closed. The ratchet releases on the sixth “click.”

2. Remove the two die retaining screws and four die retaining pins from the tool jaws.

3. Install the anvil dies in the movable jaw of the tool frame so that the chamfered edges and marked surfaces face outward. Align the dies with the screw hole, then insert the two die retaining pins included with the die assembly through the holes in the dies and into the holes in the tool frame.

4. Secure the anvil dies with the die retaining screw included with the die assembly. **DO NOT** fully tighten the screw.

5. Install indenter dies in the stationary jaw of the tool frame so that the chamfered edges and marked surfaces face outward. Align the dies with the screw hole, then insert the two die retaining pins included with the die assembly through the holes in the dies and into the holes in the tool frame.

6. Secure the indenter dies with the die retaining screw included with the die assembly. **DO NOT** fully tighten the screw.

7. Slowly close the tool handles, making sure that the dies align properly. After the anvil dies enter the indenter dies, place a 1.57±0.05-mm [.062±.002-in.] diameter copper bus bar into the center contact crimping chamber of the die assembly.

8. Continue closing the tool handles until the ratchet has engaged sufficiently to hold the dies in place, then tighten both die retaining screws.

9. To remove the die assembly from the tool frame, close the tool handles until the ratchet releases, remove the two die retaining screws and four die retaining pins, and slide the dies out of the jaws.

#### 4. CRIMPING PROCEDURE

##### NOTE



Refer to the instructions included with the connector for cable preparation and connector assembly. Before proceeding, ensure that the ferrule is on the cable and the braided shield is flared away from the cable.

##### NOTE



This tool frame has a crimp height adjustment feature. Initially, the crimp height should be verified. Make a sample crimp. Refer to the instructions included with the connector for the acceptable crimp height. If the crimp height is unacceptable, refer to Section 5 to adjust the crimp height.

#### 4.1. Crimp the Center Contact (Refer to Figure 2)

1. Close the tool handles until the die assembly is partially closed.
2. Assemble the center contact onto the center conductor of the cable, and place the center contact on the anvil in the smallest crimping chamber. Make sure the flange on the end of the center contact butts against the die.
3. Holding the cable in place, close the tool handles until the ratchet releases.
4. Allow the tool handles to open fully and remove the crimped center contact from the dies.

#### 4.2. Crimp the Ferrule (Refer to Figure 3)

1. Insert the crimped center contact into the connector body until the cable dielectric butts against the dielectric inside the connector body or until the center contact is securely positioned within the connector. Make sure that the braided shield of the cable is over the support sleeve of the connector body and that no strands from the shield enter the connector body.
2. Slide the ferrule over the braided shield and onto the connector until the ferrule butts against the shoulder of the connector body.
3. Place the ferrule in the appropriate crimping chamber of the anvil die so that the shoulder of the connector body butts against the edge of the die.

##### NOTE



Refer to the instructions included with the connector to determine the appropriate crimping chamber.

4. While holding the assembly together, close the tool handles until the dies have closed enough to secure the assembly in place.

##### CAUTION



Make sure that both sides of the ferrule are started evenly into the crimping chamber. DO NOT attempt to crimp an improperly positioned ferrule.

5. Carefully close the tool handles until the ratchet releases, then allow the tool handles to open fully, and remove the crimped connector from the dies.

#### Crimping Center Contact

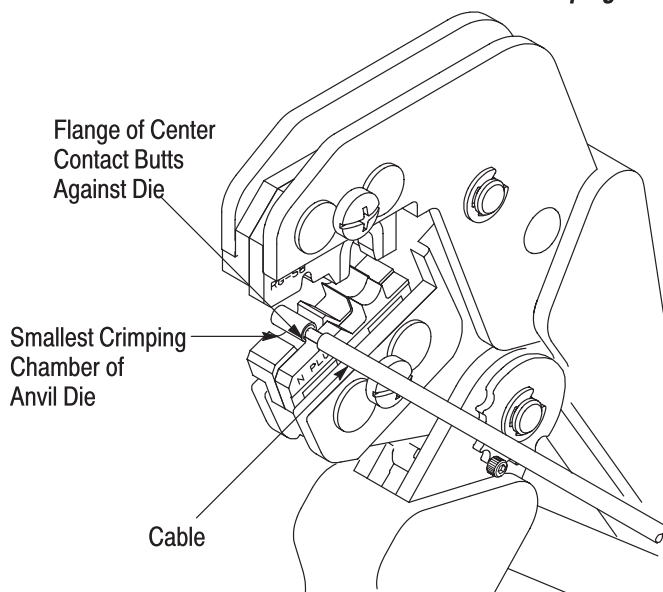
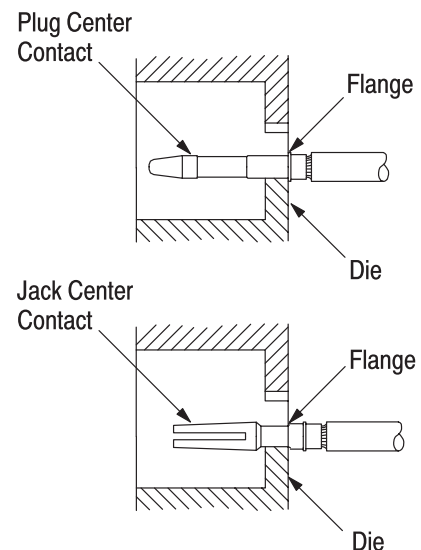

Figure 2

#### Cross-Section View



**Crimping Ferrule**

Figure 3

**5. CRIMP HEIGHT ADJUSTMENT** (Refer to Figure 4)

The tool frame ratchet mechanism features an adjustment wheel with numbered settings. If the crimp height is not acceptable, adjust the ratchet as follows:

1. Remove the lock screw from the ratchet adjustment wheel.
2. Using a screwdriver, rotate the ratchet adjustment wheel from the opposite side of the tool frame. If a tighter crimp is required, rotate the ratchet adjustment wheel *counterclockwise* to a higher-numbered setting. If a looser crimp is required, rotate the ratchet adjustment wheel *clockwise* to a lower-numbered setting.
3. Re-install the lock screw.

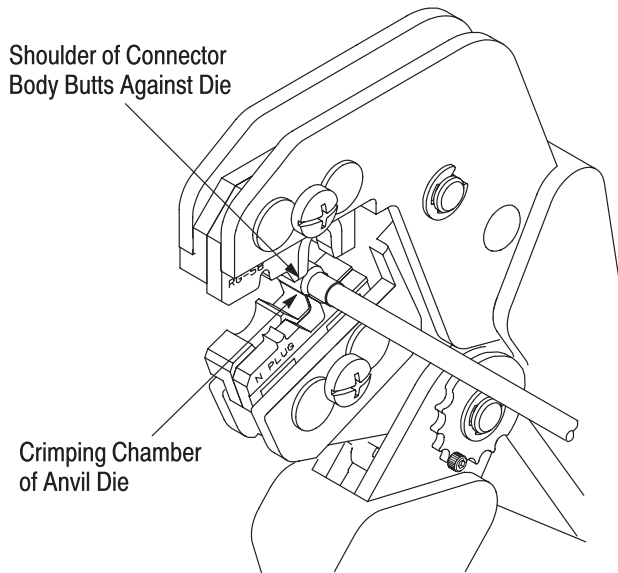
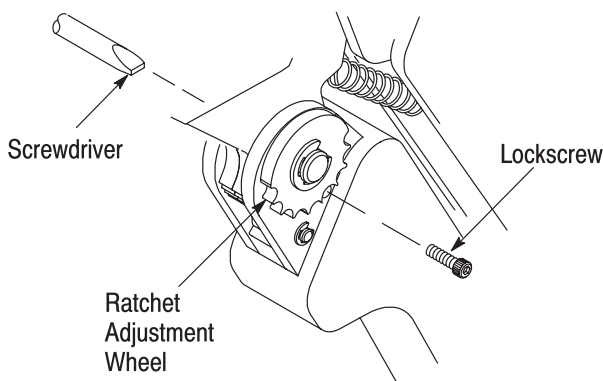

Figure 4

4. Make a sample crimp and measure the crimp height. If the crimp height is still unacceptable, remove lock screw and continue to adjust the ratchet.

**CAUTION**

*Damaged product should not be used. If damage to the product is evident, it should be cut from the wire and replaced with new product.*

**6. MAINTENANCE AND INSPECTION**

The die assembly is inspected before shipment. It is recommended that the die assembly be inspected immediately upon arrival at your facility to ensure that the dies have not been damaged during shipment.

The die assembly will perform correctly as long as: (1) the product specified is correct for the application, (2) the proper die assembly is used, (3) the die assembly has been measured to ensure that the openings are correct, and (4) the tool has been adjusted correctly.

**6.1. Maintenance**

1. Remove dust, moisture, and other contaminants with a clean, soft brush, or a clean, soft, lint-free cloth. DO NOT use any objects that could damage the dies or tool.
2. Make sure that the proper die retaining screws are properly secured.
3. When the dies are not in use, store them in a clean, dry area.

**6.2. Inspection**

1. Remove all lubrication and accumulated film from the dies by immersing the dies in a suitable commercial degreaser.
2. Make certain that die retaining screws and pins are properly secured.
3. Inspect the crimping surfaces for flattened, chipped, worn, or cracked areas. If damage is evident, the dies must be replaced. Refer to Section 7, REPLACEMENT.
4. Measure the die opening to ensure that it meets the dimensions given in Figure 5.

**7. REPLACEMENT**

Order replacements through your local representative, or call 1-800-526-5142, or send a facsimile of your purchase order to 1-717-986-7605, or write to:

CUSTOMER SERVICE (038-035)  
TYCO ELECTRONICS CORPORATION  
PO BOX 3608  
HARRISBURG PA 17105-3608

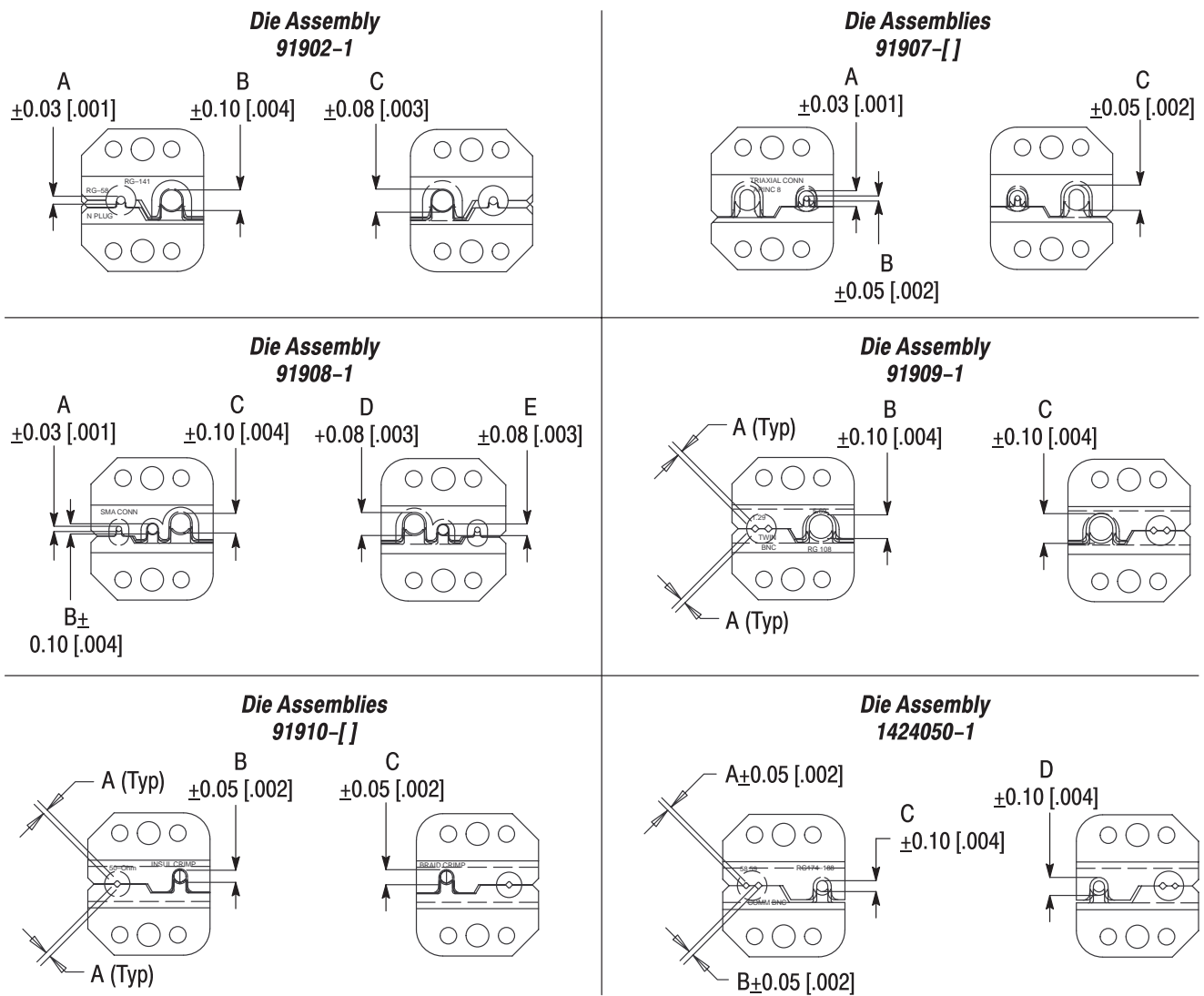

DIE ASSEMBLY	DIE CLOSURE DIMENSIONS (mm [in.])				
	A	B	C	D	E
91902-1	1.93 [.076]	4.98 [.196]	5.56 [.219]	—	—
91907-[]	1.24 [.049]	3.78 [.149]	6.07 [.239]	—	—
91908-1	1.27 [.050]	2.44 [.096]	4.72 [.186]	5.54 [.218]	2.82 [.111]
91909-1	1.257-1.321 [.050-.052]	5.69 [.224]	7.16 [.282]	—	—
91910-2	1.219-1.283 [.048-.051]	2.34 [.092]	2.77 [.109]	—	—
91910-[] (Except -2)	1.219-1.283 [.048-.051]	2.90 [.114]	3.61 [.142]	—	—
1424050-1	1.12 [.044]	1.27 [.050]	2.64 [.104]	4.32 [.170]	—

Figure 5

**8. REVISION SUMMARY**

Revisions to this instruction sheet include:

- Updated document to corporate requirements
- Modified Section 3
- Modified NOTE in Section 4