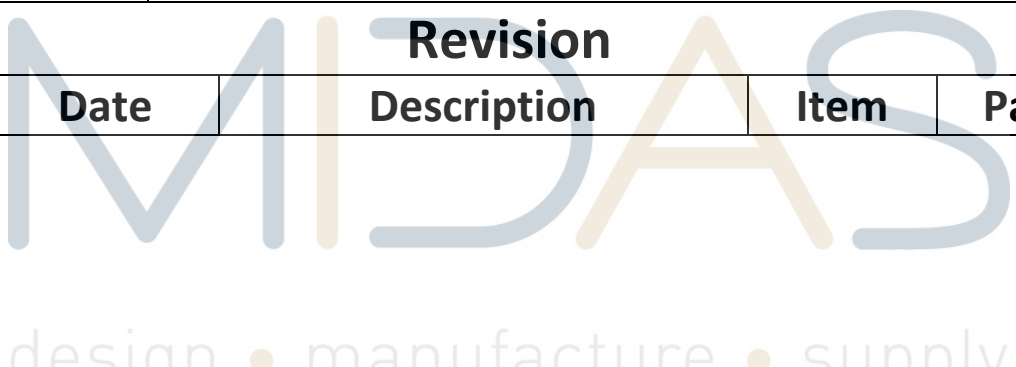

Specification				
Part Number:		MCT043C12W480272LML		
Version:				
Date:				
Revision				
No.	Date	Description	Item	Page
				

Midas Active Matrix Display Part Number System

MC T 057 A 6 * W 320240 L M L * * * * *
 1 2 3 4 5 6 7 8 9 10 11 12 13 14 15 16

- 1 = **MC:** Midas Components
- 2 = **T:** TFT **A:** Active Matrix OLED
- 3 = **Size**
- 4 = **Series**
- 5 = **Viewing Angle:** **6:** 6 O'clock **12:** 12 O'clock **0:** All round
- 6 = **Blank:** No Touch **T:** Resistive Touchscreen **C:** Capacitive Touchscreen
- 7 = **Operating Temp Range:** **S:** 0 to 50Deg C **B:** -20+60Deg C
W: -20+70Deg C **E:** -30+85Deg C
- 8 = **No of Pixels**
- 9 = **Orientation:** **P:** Portrait **L:** Landscape
- 10 = **Mode:** **R:** Reflective **M:** Transmissive **T:** Transflective
S: Sunlight Readable (transmissive)
W: White on Black (Monochrome)
- 11 = **Backlight:** **Blank:** None **L:** LED **C:** CCFL
- 12 = **Blank:** No Module/board **C:** Controller board module
- 13 = **Blank:** None **V:** Video
- 14 = **Blank:** None **B:** Bracket
- 15 = **Blank:** None **H:** Host Cable
- 16 = **Blank:** None **K:** Keyboard

TABLE OF CONTENTS

No.	Content	Page
1.	GENERAL DESCRIPTION	4
2.	MECHANICAL SPECIFICATION	5
3.	PIN DESCRIPTION	6
4.	ABSOLUTE MAXIMUM RATINGS	7
5.	BLOCK DIAGRAM	8
6.	RELATIONSHIP BETWEEN DISPLAYED COLOR AND INPUT	9
7.	ELECTRICAL CHARACTERISTICS	10
8.	OPTICAL CHARACTERISTICS	14
9.	RELIABILITY	17
10.	PRECAUTION RELATING PRODUCT HANDLING	22

MIDAS

design • manufacture • supply

1. GENERAL DESCRIPTION

1.1 Description

The specifications is model A7H\$(' 7%&K (, \$&+&@A @is a color active matrix thin film transistor (TFT) liquid crystal display (LCD) that uses amorphous silicon TFT as a switching device. This model is composed of a TFT LCD panel, a driving circuit, a back light system. This TFT LCD has a 4.3 (16:9) inch diagonally measured active display area with WQVGA (480 horizontal by 272 vertical pixel) resolution.

1.2 Features:

No.	Item	Specification	Unit
1	Panel Size	4.3"	Inch
2	Number of Pixels	480 (W) x RGB x 272 (H)	Pixels
3	Active Area	95.04 (W) × 53.856 (H)	mm
4	Pixel Pitch	0.198 (W) x 0.198(H)	mm
5	Outline Dimension	105.5 (W) × 67.2 (H) × 3.75 (T)	mm
6	Number of Colors	16.7M	- -
7	Display Mode	MVA / Normally Black / Transmissive	- -
8	View Direction	Free of direction	
9	Display Format	RGB vertical stripe	- -
10	Surface Treatment	Clear	- -
11	Contrast Ratio	500 (Typ.)	- -
12	Luminance (cd/m ²)	800 (typical)	cd/m ²
13	Interface	RGB 24bit Interface	- -
14	Backlight	White LED	- -
15	Driver IC	--	- -
16	Operation Temperature	-20 ~ 70	°C
17	Storage Temperature	-30 ~ 80	°C
18	Weight	(60)	g

2. MECHANICAL SPECIFICATION

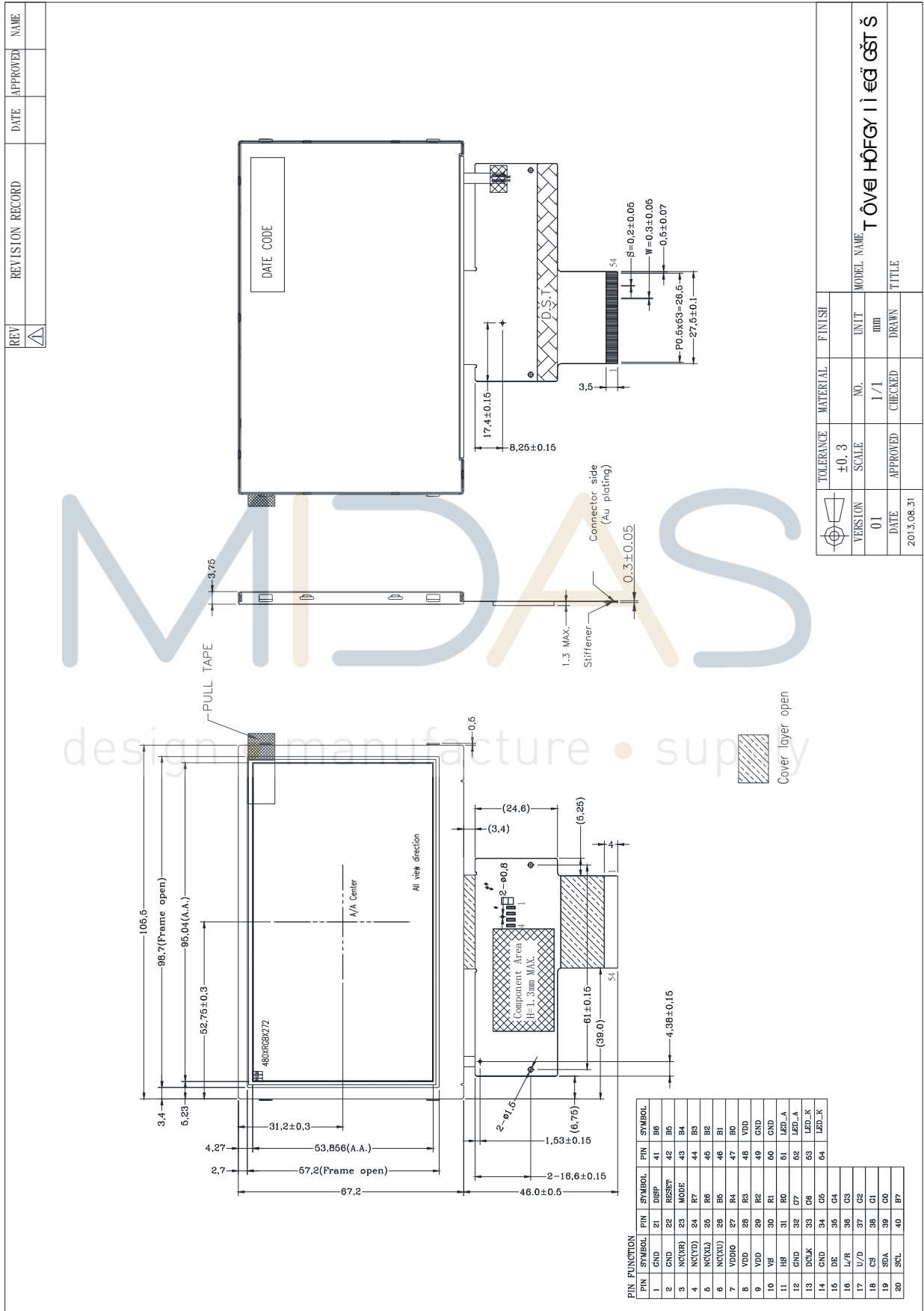

3. PIN DESCRIPTION

Pin No.	Symbol	I/O	Function	Remark
1	GND	P	Ground	
2	GND	P	Ground	
3	NC	-	No connect	
4	NC	-	No connect	
5	NC	-	No connect	
6	NC	-	No connect	
7	VDDIO	P	Power supply for digital interface I/O pin	
8	VDD	P	Power supply for digital circuit	
9	VDD	P	Power supply for digital circuit	
10	VS	I	Vertical Sync Input	
11	HS	I	Horizontal Sync Input	
12	GND	P	Ground	
13	DCLK	I	Dot Data Clock, latching data at the falling edge	
14	GND	P	Ground	
15	DE	I	Data enable	
16	L/R	I	Horizontal scan direction control	
17	U/D	I	Vertical scan direction control	
18	CS	I	Serial communication chip select	
19	SDA	I	Serial communication data input and output	
20	SCL	I	Serial communication clock input	
21	DISP	I	DISP = Low: standby mode DISP = High : Normal display	
22	RESET	I	Global reset	
23	MODE	I	Charge pump power selection	
24-31	R7-R0	I	Red data(MSB-LSB)	
32-39	G7-G0	I	Green data(MSB-LSB)	
40-47	B7-B0	I	Blue data(MSB-LSB)	
48	VDD	P	Power supply for digital circuit	
49	GND	P	Ground	
50	GND	P	Ground	
51-52	LED_A	P	Power supply for backlight	
53-54	LED_K	P	Power supply for backlight	

4. ABSOLUTE MAXIMUM RATINGS

4.1 Electrical Absolute Rating

4.1.1 TFT LCD Module

Item	Symbol	Values		Unit	Note
		Min	Max.		
Power supply voltage	VDD	-0.3	4.5	V	
Power supply voltage	VDDIO	-0.3	4.5	V	

4.1.2 Environment Absolute Rating

Item	Symbol	Values			Unit	Note
		Min	Typ	Max.		
Operating Temperature	Topa	-20		70	°C	Ambient temperature
Storage Temperature	Tstg	-30		80	°C	

MIDAS

design • manufacture • supply





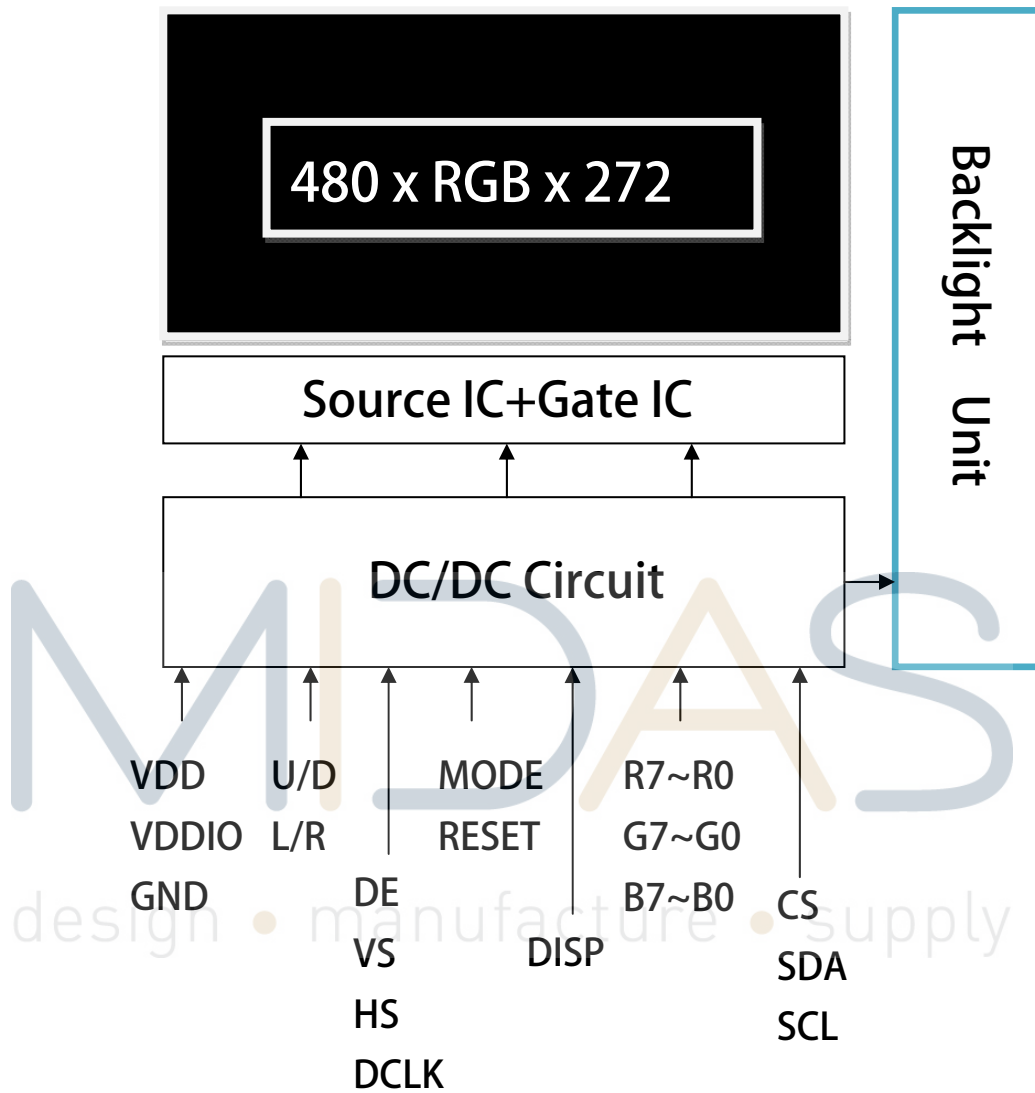





















5. BLOCK DIAGRAM

5.1 TFT LCD Module



6. Relationship Between Displayed Color and Input

6.1 8 bit

		Color & Gray Scale	Data Signal																							
			R7	R6	R5	R4	R3	R2	R1	R0	G7	G6	G5	G4	G3	G2	G1	G0	B7	B6	B5	B4	B3	B2	B1	B0
Basic Color		Black	0	0	0	0	0	0	0	0	0	0	0	0	0	0	0	0	0	0	0	0	0	0	0	0
		Red	1	1	1	1	1	1	1	1	0	0	0	0	0	0	0	0	0	0	0	0	0	0	0	0
		Green	0	0	0	0	0	0	0	0	1	1	1	1	1	1	1	1	0	0	0	0	0	0	0	0
		Blue	0	0	0	0	0	0	0	0	0	0	0	0	0	0	0	0	1	1	1	1	1	1	1	1
		Cyan	0	0	0	0	0	0	0	0	1	1	1	1	1	1	1	1	1	1	1	1	1	1	1	1
		Magenta	1	1	1	1	1	1	1	1	0	0	0	0	0	0	0	0	1	1	1	1	1	1	1	1
		Yellow	1	1	1	1	1	1	1	1	1	1	1	1	1	1	1	1	0	0	0	0	0	0	0	0
		White	1	1	1	1	1	1	1	1	1	1	1	1	1	1	1	1	1	1	1	1	1	1	1	1
Red		Black	0	0	0	0	0	0	0	0	0	0	0	0	0	0	0	0	0	0	0	0	0	0	0	
		Red(1)	0	0	0	0	0	0	0	1	0	0	0	0	0	0	0	0	0	0	0	0	0	0	0	
		Red(2)	0	0	0	0	0	0	1	0	0	0	0	0	0	0	0	0	0	0	0	0	0	0	0	
	:	:	:	:	:	:	:	:	:	:	:	:	:	:	:	:	:	:	:	:	:	:	:	:	:	
		Red(127)	0	1	1	1	1	1	1	1	0	0	0	0	0	0	0	0	0	0	0	0	0	0	0	
	:	:	:	:	:	:	:	:	:	:	:	:	:	:	:	:	:	:	:	:	:	:	:	:	:	
		Red(254)	1	1	1	1	1	1	1	0	0	0	0	0	0	0	0	0	0	0	0	0	0	0	0	
		Red(255)	1	1	1	1	1	1	1	1	0	0	0	0	0	0	0	0	0	0	0	0	0	0	0	
Green		Black	0	0	0	0	0	0	0	0	0	0	0	0	0	0	0	0	0	0	0	0	0	0	0	
		Green(1)	0	0	0	0	0	0	0	0	0	0	0	0	0	0	1	0	0	0	0	0	0	0	0	
		Green(2)	0	0	0	0	0	0	0	0	0	0	0	0	0	1	0	0	0	0	0	0	0	0	0	
	:	:	:	:	:	:	:	:	:	:	:	:	:	:	:	:	:	:	:	:	:	:	:	:	:	
		Green(127)	0	0	0	0	0	0	0	0	0	1	1	1	1	1	1	1	0	0	0	0	0	0	0	
	:	:	:	:	:	:	:	:	:	:	:	:	:	:	:	:	:	:	:	:	:	:	:	:	:	
		Green(254)	0	0	0	0	0	0	0	0	1	1	1	1	1	1	1	0	0	0	0	0	0	0	0	
		Green(255)	0	0	0	0	0	0	0	0	1	1	1	1	1	1	1	0	0	0	0	0	0	0	0	
Blue		Black	0	0	0	0	0	0	0	0	0	0	0	0	0	0	0	0	0	0	0	0	0	0	0	
		Blue(1)	0	0	0	0	0	0	0	0	0	0	0	0	0	0	0	0	0	0	0	0	0	0	1	
		Blue(2)	0	0	0	0	0	0	0	0	0	0	0	0	0	0	0	0	0	0	0	0	0	0	1	
	:	:	:	:	:	:	:	:	:	:	:	:	:	:	:	:	:	:	:	:	:	:	:	:	:	
		Blue(127)	0	0	0	0	0	0	0	0	0	0	0	0	0	0	0	0	0	1	1	1	1	1	1	
	:	:	:	:	:	:	:	:	:	:	:	:	:	:	:	:	:	:	:	:	:	:	:	:	:	
		Blue(254)	0	0	0	0	0	0	0	0	0	0	0	0	0	0	0	0	1	1	1	1	1	1	0	
		Blue(255)	0	0	0	0	0	0	0	0	0	0	0	0	0	0	0	0	1	1	1	1	1	1	1	

0 : Low level voltage, 1 :High level voltage

Each basic color can be displayed in 256 gray scales from 8 bit data signals. With the combination of total 24 bit data signals, the 16,777,216-color display can be achieved on the screen.

7. ELECTRICAL CHARACTERISTICS

7.1 TFT LCD Module

Item	Symbol	Value			Unit	Note
		Min.	Typ.	Max.		
Power supply voltage	VDD	3.0	3.3	3.6	V	
	VDDIO	1.65	1.8	VDD	V	
Input Voltage for logic	H Level	V_{IH}	$0.7 \times V_{DDIO}$	-	VDDIO	V
	L Level	V_{IL}	0	-	$0.3 \times V_{DDIO}$	V
Digital Current	I_{DD}	-	(12.5)	(19)	mA	

7.2 Backlight Unit

Item	Symbol	Value			Unit	Condition
		Min.	Typ.	Max.		
LED Voltage	V_L	(18.6)	(19.8)	(21)	V	
LED Current	I_f	-	(40)	(50)	mA	6S2P
Power Consumption	P_{BL}	-	(792)	(1050)	mW	
LED Life Time (25°C)	-	(20000)	-	-	hr	(1)

Note (1): The “LED life time” is defined as the module brightness decrease to 50% original brightness that the ambient temperature is 25°C 60% RH.

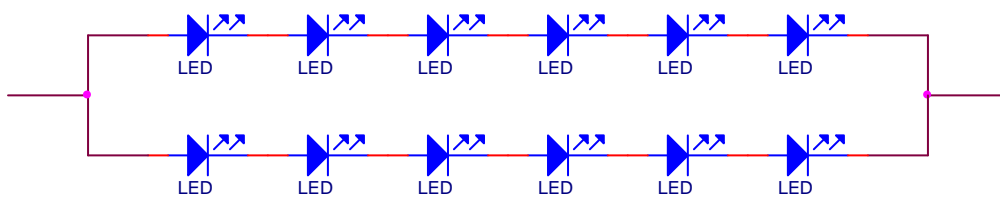

7.3 INTERFACE SPECIFICATIONS

7.3.1 AC Timing characteristics

Parameter	Symbol	Min	Typ	Max	Unit
CLK pulse duty	T _{cw}	40	50	60	%
Hsync width	T _{hw}	1.0	-	-	DCLK
Hsync period	T _h	55	60	65	us
Vsync setup time	T _{vst}	12	-	-	ns
Vsync hold time	T _{vhd}	12	-	-	ns
Hsync setup time	T _{hst}	12	-	-	ns
Hsync hold time	T _{hhd}	12	-	-	ns
Data set-up time	T _{dsu}	12	-	-	ns
Data hold time	T _{dhd}	12	-	-	ns
DE set-up time	T _{desu}	12	-	-	ns
DE hold time	T _{dehd}	12	-	-	ns

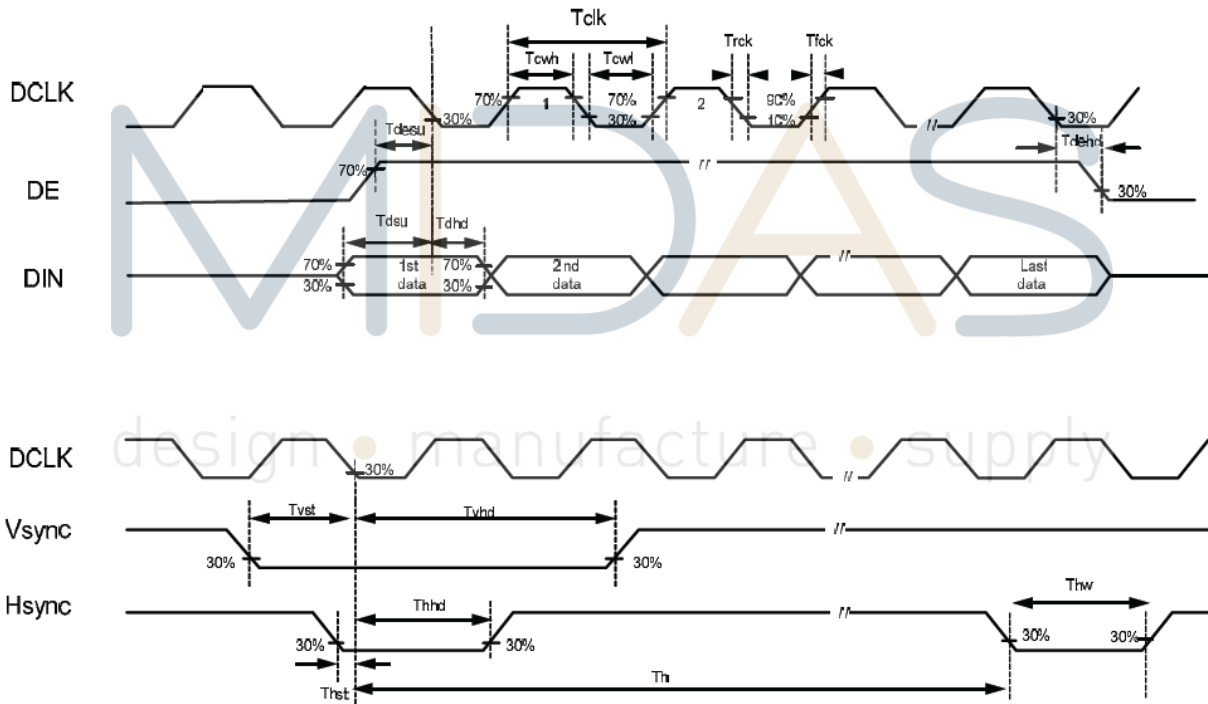

7.3.2 SYNC Mode Input Timing Table

Signal	Parameter	Symbol	Min.	Typ.	Max.	Unit.	Note
DCLK	DCLK frequency	Fclk	5	9	12	MHz	
	DCLK period	Tclk	83	110	200	ns	
Hsync	Period Time	Th	490	531	605	DCLK	
	Display Period	Thdisp	-	480	-	DCLK	
	Back Porch	Thbp	8	43	-	DCLK	
	Front Porch	Thfp	2	8	-	DCLK	
	Pulse Width	Thw	1	-	-	DCLK	
Vsync	Period Time	Tv	275	288	335	H	
	Display Period	Tvdisp	-	272	-	H	
	Back Porch	Tvbp	2	12	-	H	
	Front Porch	Tvfp	1	4	-	H	
	Pulse Width	Tvw	1	10	-	H	

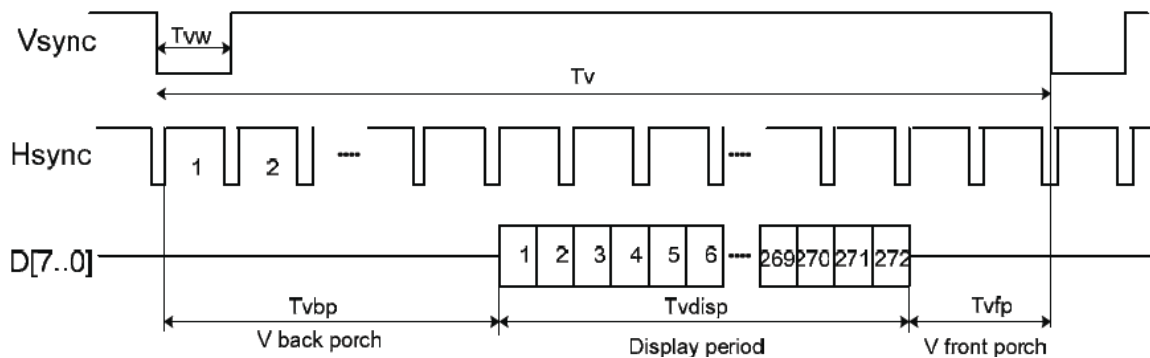
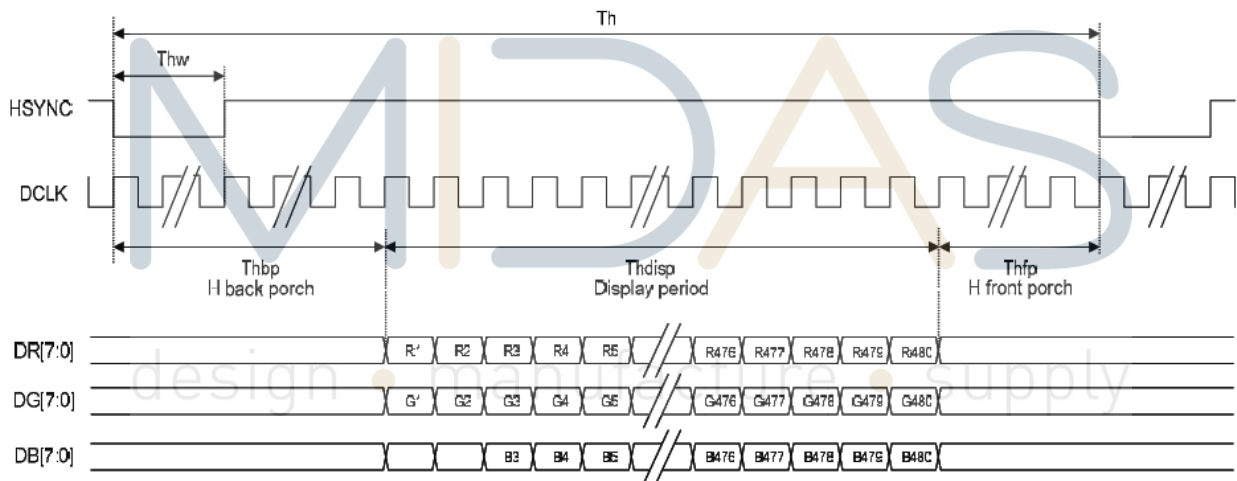

7.4 Power On / Off Sequence

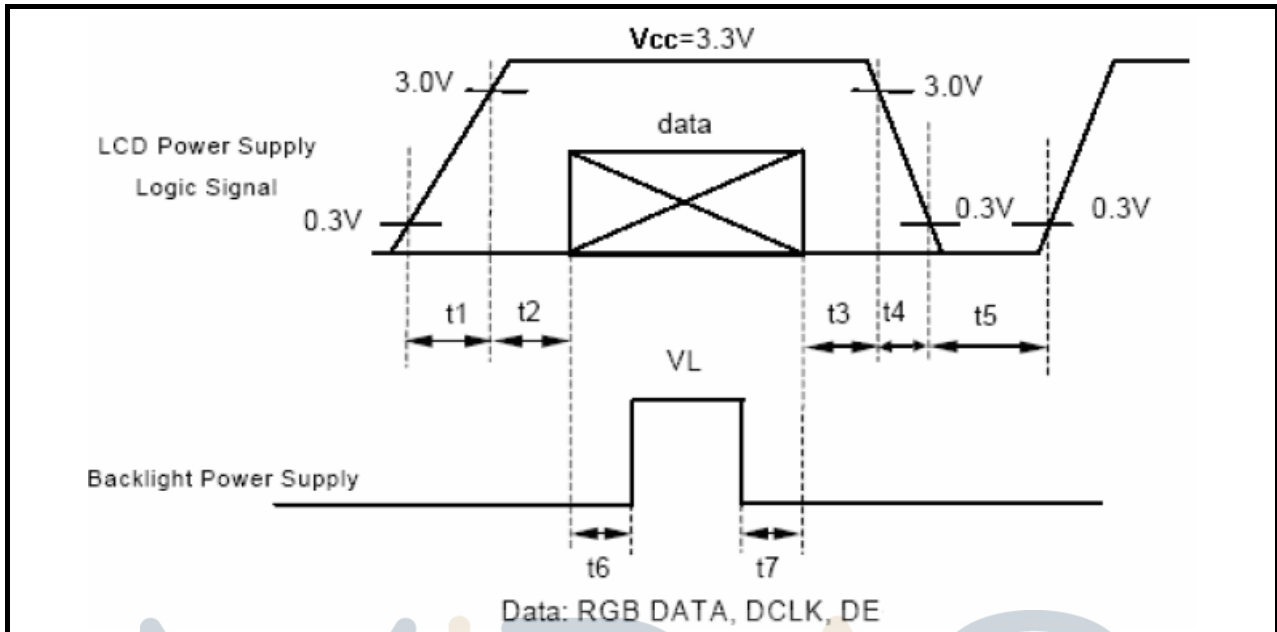

Data: RGB DATA, DCLK, DE

$t_1 \leq 10\text{ms} : 1\text{sec} \leq t_5$
 $50\text{ms} \leq t_2 : 200\text{ms} \leq t_6$
 $0 < t_3 \leq 50\text{ms} : 200\text{ms} \leq t_7$
 $0 < t_4 \leq 10\text{ms}$

MIDAS

design • manufacture • supply

8. OPTICAL CHARACTERISTICS

Item		Symbol	Condition	Min.	Typ.	Max.	Unit
Brightness		--	Note1, Note 3, ($\theta = 0^\circ$; Normal Viewing Angle)	700	800	--	cd/m ²
Uniformity		B-uni		70	75	-	%
Contrast Ratio		CR		400	500	--	--
Response Time		Tr		--	5	--	ms
		Tf		--	20	--	ms
Color Chromaticity	White	Wx	Center CR \geq 10	0.260	0.310	0.360	--
		Wy		0.280	0.330	0.380	--
View angle	Horizontal	θ_{x+}		80	--	--	
		θ_{x-}		80	--	--	
	Vertical	θ_{Y+}	80	--	--		
		θ_{Y-}	80	--	--		
Image sticking		tis	2 hours	--	--	2	Sec

Note : The following optical specifications shall be measured in a darkroom or equivalent state (ambient luminance ≤ 1 lux, and at room temperature). The operation temperature is $25^\circ\text{C} \pm 2^\circ\text{C}$. The measurement method is shown in Note1.

Note1: The method of optical measurement:

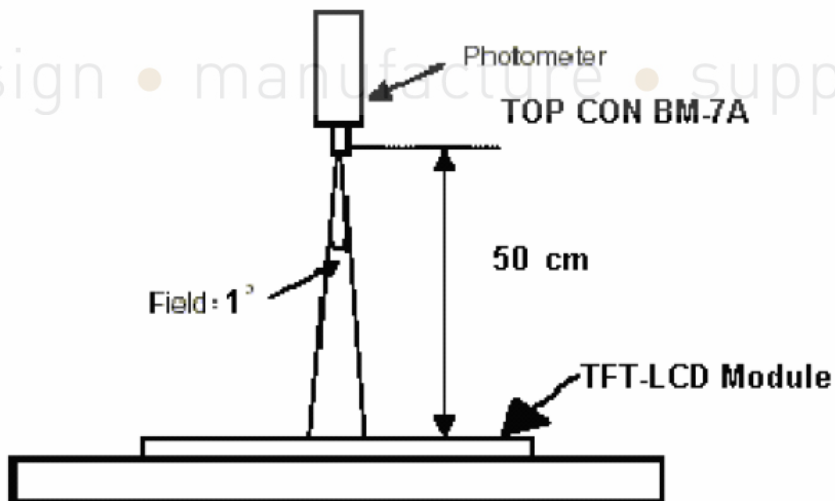

Note2: Measured at the center area of the panel and at the viewing angle of the $\theta_x = \theta_y = 0^\circ$

Note3: Definition of Contrast Ratio (CR):

CR = Luminance with all pixels in white state \div Luminance with all pixels in Black state

Note4: Definition of Viewing Angle:

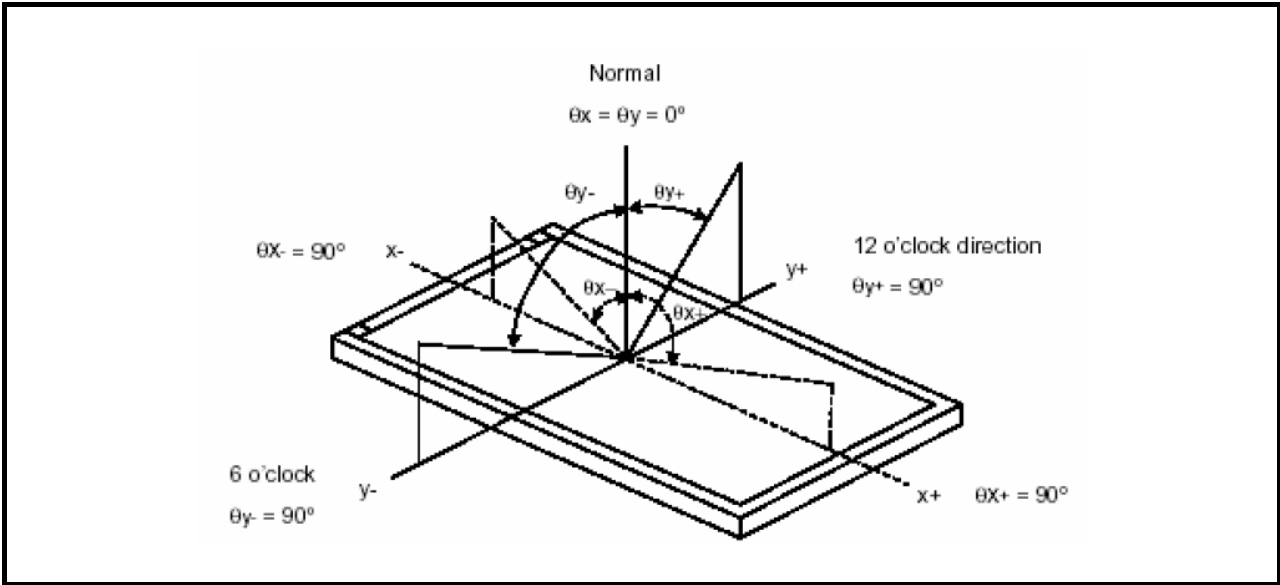

Note 5: Definition of Brightness Uniformity (B-uni):

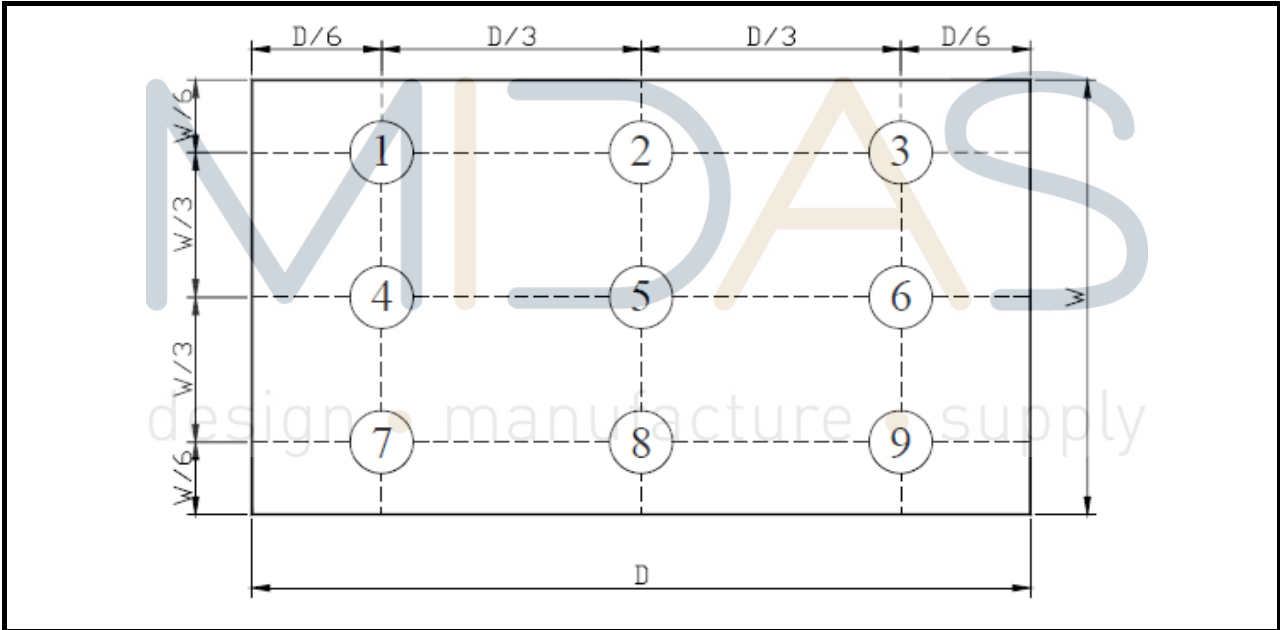

$$B\text{-uni} = (\text{Minimum luminance of 9 points} \div \text{Maximum luminance of 9 points}) \times 100\%$$

Note6: Definition of Response Time:

The Response Time is set initially by defining the “Rising Time (Tr)” and the “Falling Time (Tf)” respectively. Tr and Tf are defined as following figure

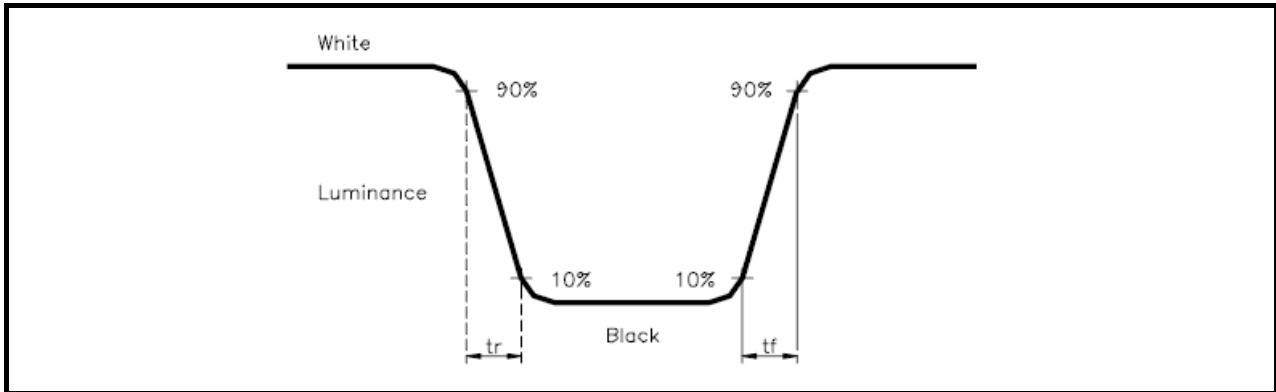

Note 7: Definition of Chromaticity:

The color coordinates (W_x, W_y), (R_x, R_y), (G_x, G_y), and (B_x, B_y) are obtained with all pixels in the viewing field at white, red, green, and blue states, respectively.

Note 8: Definition of Image sticking (t_{is}):

Continuously display the test pattern shown in the figure below for 2 hours. Then display a completely white screen. The previous image shall not persist more than 2 sec at 25 °C

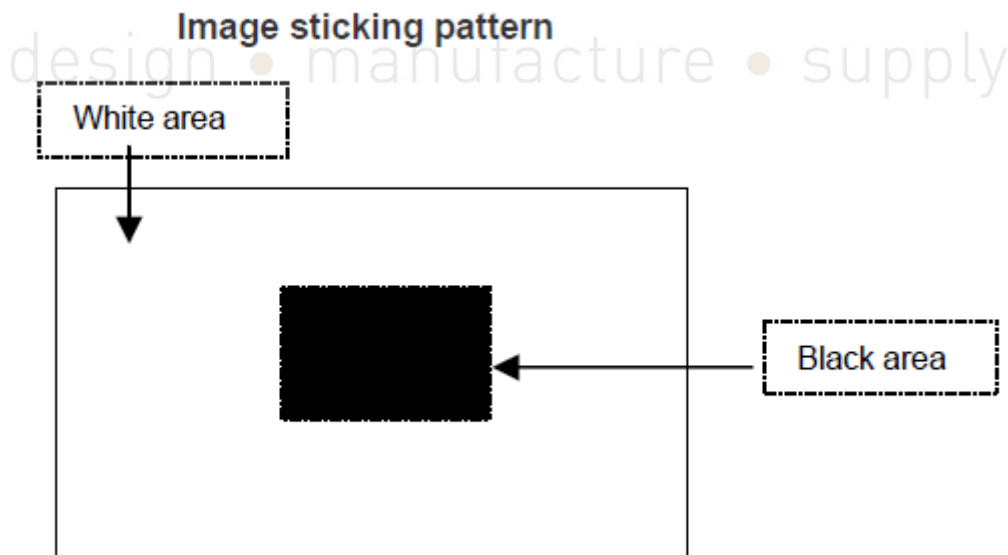

9. RELIABILITY

9.1 Test Condition

9.1.1 Temperature and Humidity(Ambient Temperature)

Temperature : $25 \pm 5^{\circ}\text{C}$

Humidity : $65 \pm 5\%$

9.1.2 Operation

Unless specified otherwise, test will be conducted under function state.

9.1.3 Container

Unless specified otherwise, vibration test will be conducted to the product itself without putting it in a container.

9.1.4 Test Frequency

In case of related to deterioration such as shock test. It will be conducted only once.

9.2 TESTS

No.	ITEM	CONDITION CRITERION
1	High Temperature Storage	80°C, 120 hrs
2	Low Temperature Storage	-30°C, 120 hrs
3	High Temperature Operating	70°C, 120 hrs
4	Low Temperature Operating	-20°C, 120 hrs
5	High Temperature/Humidity Non-Operating	60°C, 90%RH, 120 hrs
6	Temperature Shock Non-Operating	-30°C \longleftrightarrow 80°C (0.5hr each), 25 cycles
7	Vibration Test Non-Operating	Frequency:0 ~ 55 Hz Amplitude:1.5 mm Sweep Time:11min Test Period:6 Cycles for each Direction of X,Y,Z
8	Electro-static Discharge Non-Operating	150pF, 330Ω Air:± 12KV;Contact: ±6KV 10 times/point;4 points/panel face

9.3 JUDGEMENT STANDARD

The judgment of the above test should be made as follow:

Pass: Normal display image with no obvious non-uniformity and no line defect. Partial transformation of the module parts should be ignored.

Fail: No display image, obvious non-uniformity, or line defects.



9.4 INCOMING INSPECTION STANDARDS

No.	Parameter	Criteria														
1	Operating	Display function: No Display malfunction (Major)														
		Contrast ratio (Black, White): Does not meet specified range in the spec. (Major) (Note:3)														
		Line Defect: No obvious Vertical and Horizontal line defect in bright, dark and colored. (Major) (Note:1)														
		Point Defect (Red, green, blue, dark): Active area ≤ 5 dots (Minor) (Note:1)														
		<table border="1"> <thead> <tr> <th rowspan="2">Item</th> <th colspan="2">Acceptable number</th> <th rowspan="2">Total</th> </tr> <tr> <th>A</th> <th>B</th> </tr> </thead> <tbody> <tr> <td>Bright</td> <td>0</td> <td>2</td> <td rowspan="3">5</td> </tr> <tr> <td>Dark</td> <td>2</td> <td>4</td> </tr> <tr> <td>Total</td> <td>2</td> <td>4</td> </tr> </tbody> </table>	Item	Acceptable number		Total	A	B	Bright	0	2	5	Dark	2	4	Total
Item	Acceptable number			Total												
	A	B														
Bright	0	2	5													
Dark	2	4														
Total	2	4														
2	External Inspection (non-operating)	Non-uniformity: Visible through 6%ND filter. (Minor)														
		Foreign material in Black or White spots shape ($W > 1/4L$)														
		<table border="1"> <thead> <tr> <th>Zone Dimension</th> <th>Acceptable number</th> <th>Class Of Defects</th> <th>AQL Level</th> </tr> </thead> <tbody> <tr> <td>$D > 0.5$</td> <td>0</td> <td rowspan="3">Minor</td> <td rowspan="3">1.5</td> </tr> <tr> <td>$0.1 \leq D \leq 0.5$</td> <td>4</td> </tr> <tr> <td>$D \leq 0.1$</td> <td>*</td> </tr> </tbody> </table> <p>$D = (\text{Long} + \text{Short}) / 2$ * : Disregard</p>	Zone Dimension	Acceptable number	Class Of Defects	AQL Level	$D > 0.5$	0	Minor	1.5	$0.1 \leq D \leq 0.5$	4	$D \leq 0.1$	*		
		Zone Dimension	Acceptable number	Class Of Defects	AQL Level											
		$D > 0.5$	0	Minor	1.5											
$0.1 \leq D \leq 0.5$	4															
$D \leq 0.1$	*															
Foreign Material in Line or spiral shape ($W \leq 1/4L$) (Note: 4)																
<table border="1"> <thead> <tr> <th>L (mm)</th> <th>Zone W(mm)</th> <th>Acceptable number</th> <th>Class Of Defects</th> <th>AQL Level</th> </tr> </thead> <tbody> <tr> <td>$L > 2$</td> <td>$W > 0.1$</td> <td>0</td> <td rowspan="3">Minor</td> <td rowspan="3">1.5</td> </tr> <tr> <td>$0.5 < L \leq 2$</td> <td>$0.03 < W \leq 0.1$</td> <td>1</td> </tr> <tr> <td>$L \leq 0.5$</td> <td>$W \leq 0.03$</td> <td>*</td> </tr> </tbody> </table> <p>L : Length W : Width * : Disregard</p>	L (mm)	Zone W(mm)	Acceptable number	Class Of Defects	AQL Level	$L > 2$	$W > 0.1$	0	Minor	1.5	$0.5 < L \leq 2$	$0.03 < W \leq 0.1$	1	$L \leq 0.5$	$W \leq 0.03$	*
L (mm)	Zone W(mm)	Acceptable number	Class Of Defects	AQL Level												
$L > 2$	$W > 0.1$	0	Minor	1.5												
$0.5 < L \leq 2$	$0.03 < W \leq 0.1$	1														
$L \leq 0.5$	$W \leq 0.03$	*														
2	External Inspection (non-operating)	Dimension: Outline (Major)														
		Bezel appearance: uneven (Minor)														
		Scratch on the polarize: (Note:2)														
		<table border="1"> <thead> <tr> <th>L (mm)</th> <th>Zone W(mm)</th> <th>Acceptable number</th> <th>Class Of Defects</th> <th>AQL Level</th> </tr> </thead> <tbody> <tr> <td>--</td> <td>$W > 0.1$</td> <td>0</td> <td rowspan="2">Minor</td> <td rowspan="2">1.5</td> </tr> <tr> <td>$L \leq 2$</td> <td>$W \leq 0.1$</td> <td>3</td> </tr> </tbody> </table> <p>L : Length W : Width * : Disregard</p>	L (mm)	Zone W(mm)	Acceptable number	Class Of Defects	AQL Level	--	$W > 0.1$	0	Minor	1.5	$L \leq 2$	$W \leq 0.1$	3	
		L (mm)	Zone W(mm)	Acceptable number	Class Of Defects	AQL Level										
--	$W > 0.1$	0	Minor	1.5												
$L \leq 2$	$W \leq 0.1$	3														
Dent or bubble on the polarize (Note:2)																
<table border="1"> <thead> <tr> <th>Zone Dimension</th> <th>Acceptable number</th> <th>Class Of Defects</th> <th>AQL Level</th> </tr> </thead> <tbody> <tr> <td>$D \leq 0.05$</td> <td>*</td> <td rowspan="2">Minor</td> <td rowspan="2">1.5</td> </tr> <tr> <td>$D \leq 0.3$</td> <td>3</td> </tr> </tbody> </table> <p>$D = (\text{Long} + \text{Short}) / 2$ * : Disregard</p>	Zone Dimension	Acceptable number	Class Of Defects	AQL Level	$D \leq 0.05$	*	Minor	1.5	$D \leq 0.3$	3						
Zone Dimension	Acceptable number	Class Of Defects	AQL Level													
$D \leq 0.05$	*	Minor	1.5													
$D \leq 0.3$	3															

Class of defects			Definition
	Major	AQL 0.65%	It is a defect that is likely to result in failure or to reduce materially the usability of the product for the intended function.
Minor	AQL 1.5%	It is a defect that will not result in functioning problem with deviation classified.	

Note1:

(a) Bright point defect is defined as point defect of R,G,B with area $> 1/2$ pixel respectively

(b) Dark point defect is defined as visible in full white pattern.

(c) Definition of distribution of point defect is as follows:

- minimum separation between dark point defects should be larger than 5mm.
- minimum separation between bright point defects should be larger than 5mm.

(d) Definition of joined bright point defect and joined dark point defect are as follows:

- Two or more joined bright point defects must be nil.
- Three joined dark point defects must be nil.
- Coupling of one dark and one bright point in junction is counted as one dark and bright spot with 1 pair maximum.
- Two Joined dark point is counted as two dark points with 2 pair maximum.

Note2: The external inspection should be conducted at the distance 30 ± 5 cm between the eyes of inspector and the panel.

Note3: Luminance measurement for contrast ratio is at the distance 50 ± 5 cm between the detective head and the panel with ambient luminance less than 1 lux. Contrast ratio is obtained at optimum view angle.

Note4: W-Width in mm , L-length of Max.(L1,L2) in mm.

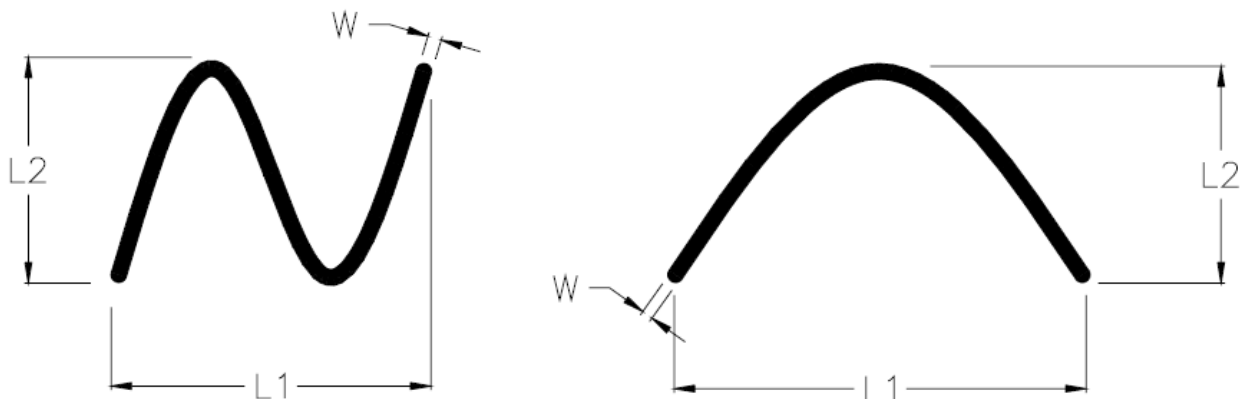

9.5 Sampling Condition

Unless otherwise agree in written, the sampling inspection shall be applied to the incoming inspection of customer.

Lot size: Quantity of shipment lot per model.

Sampling type: normal inspection, single sampling

Sampling table: MIL-STD-105E

Inspection level: Level II

9.6 Inspection conditions

The LCD shall be inspected under 40W white fluorescent light.

$\theta \leq 45^\circ$ inspection under non-operating condition.

$\theta \leq 5^\circ$ inspection under operating condition

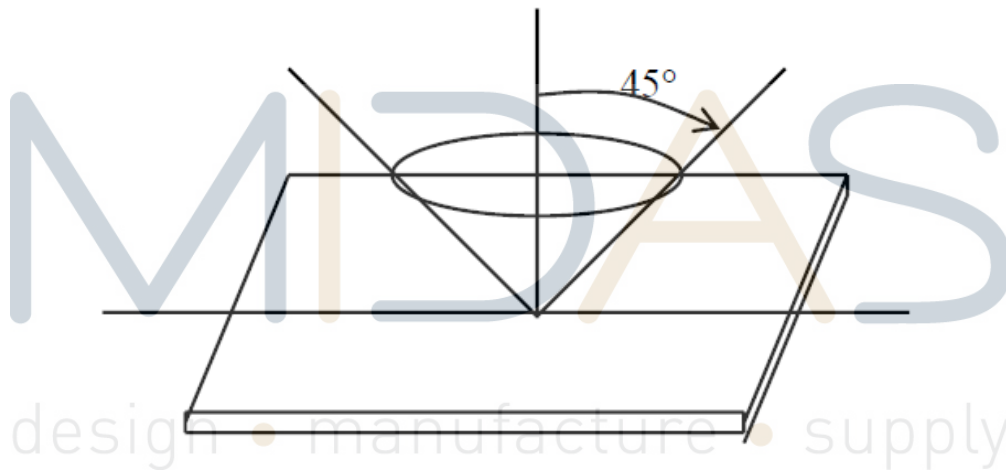

Definition of applicable Zones

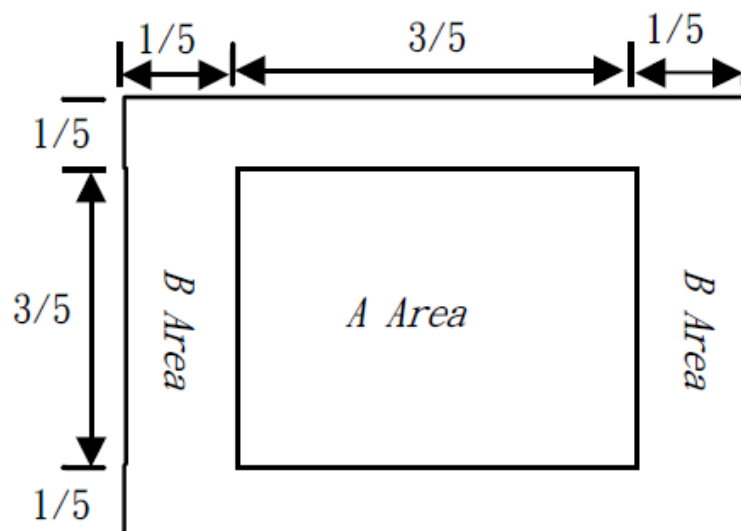

10. PRECAUTION RELATING PRODUCT HANDLING

10.1 SAFETY

10.1.1 If the LCD panel breaks , be careful not to get the liquid crystal to touch your skin.

10.1.2 If the liquid crystal touches your skin or clothes , please wash it off immediately by using soap and water.

10.2 HANDLING

10.2.1 Avoid any strong mechanical shock which can break the glass.

10.2.2 Avoid static electricity which can damage the CMOS LSI—When working with the module, be sure to ground your body and any electrical equipment you may be using.

10.2.3 Do not remove the panel or frame from the module.

10.2.4 The polarizing plate of the display is very fragile. So , please handle it very carefully, Do not touch, push or rub the exposed polarizing with anything harder than an HB pencil lead (glass , tweezers , etc.)

10.2.5 Do not wipe the polarizing plate with a dry cloth, as it may easily scratch the surface of plate.

10.2.6 Do not touch the display area with bare hands , this will stain the display area.

10.2.7 Do not use ketonics solvent & aromatic solvent. Use with a soft cloth soaked with a cleaning naphtha solvent.

10.2.8 To control temperature and time of soldering is $280 \pm 10^{\circ}\text{C}$ and 3-5 sec.

10.2.9 To avoid liquid (include organic solvent) stained on LCM.

10.3 STORAGE

10.3.1 Store the panel or module in a dark place where the temperature is $25^{\circ}\text{C} \pm 5^{\circ}\text{C}$ and the humidity is below 65% RH.

10.3.2 Do not place the module near organics solvents or corrosive gases.

10.3.3 Do not crush, shake, or jolt the module.