

MVT-H101000	1024 x 600	HDMI Interface	Aurum TFT Series
Specification			
Version: 1	Date: 08/12/2025		
Revision			
1	08/12/2025	First issue	
			Created By
			WE
			Checked By
			AB
			Box Quantity
			Weight / Display

Display Features	
Display Size	10.10"
Resolution	1024 x 600
Orientation	Landscape
Appearance	RGB
Supply Voltage	5-12V
Interface	HDMI
Brightness	1200 cd/m ²
Touchscreen	---
Module Size	235.00 x 143.00 x 19.85mm
Operating Temperature	-10°C ~ +70°C
Pinout	N/A
Pitch	N/A



Also Available	
Part Number	Description
MVT-L101000(LCR)	10.1" LVDS TFT, optional Lugs(L), CTP(C), RTP (R)
MVT-H101000(LCR)	10.1" HDMI TFT, optional Lugs(L), CTP(C), RTP (R)
MVT-E101000(LCR)	10.1" Embedded TFT, optional Lugs(L), CTP(C), RTP (R)

Display Accessories	
Part Number	Description





The module integrates a high-brightness TFT panel with a dedicated HDMI interface board, providing a ready-to-use display solution for embedded, industrial, and commercial applications. Designed for ease of integration, the module accepts a single 5–12 V supply and directly converts HDMI input signals to the required LVDS interface for the display.

The module is available in 4.3-inch to 10.1-inch panel sizes with adjustable brightness options up to 1250 nits, ensuring readability in outdoor and high-ambient-light environments. An optional touch panel is supported via a USB Type-C interface or with a 1mm JST pitch connector. The optically bonded touch can be configured as USB HID or I2C.

For system flexibility, display brightness can be controlled using either the integrated PWM generator or with optional external buttons. Mechanical features such as an optimised board outline for cable bend radius and optional mounting lugs simplify installation in constrained enclosures.

This solution eliminates the need for additional interface design, allowing rapid deployment of HDMI-based systems with minimal development effort.



General Data

Complete Module

Feature	Value
Size (inch)	10.10
Resolution (pixels)	1024(Horizontal) x 600(Vertical)
Type	TFT/IPS/NORMALLY BLACK/TRANSMISSIVE
Product Size (mm)	235.00 x 143.00 x 19.85mm
Active Area (mm)	222.72 x 125.28
Interface	HDMI
Connector type	Type A
Colour Depth	16.7 M
Pixel pitch (mm)	0.2175 x 0.2088
Luminance (cd/m ²)	1200
Viewing Direction (O'clock)	All

Aurum TFT Part Number Definition Example

MVT-	H	1010	00	L	C
1	2	3	4	5	6

1 MVT: Midas Versatile TFT

2 Interface: R = RGB L = LVDS H = HDMI E = Embedded

3 Size: 4.3" = 0430 5.0" = 0500 7.0" = 0700 10.1" = 1010

4 Series: 00, 01, 02 etc

5 Lugs: Blank = No Mounting Lugs L = Mounting Lugs

6 Touch: Blank = No Touch C = CTP R = RTP



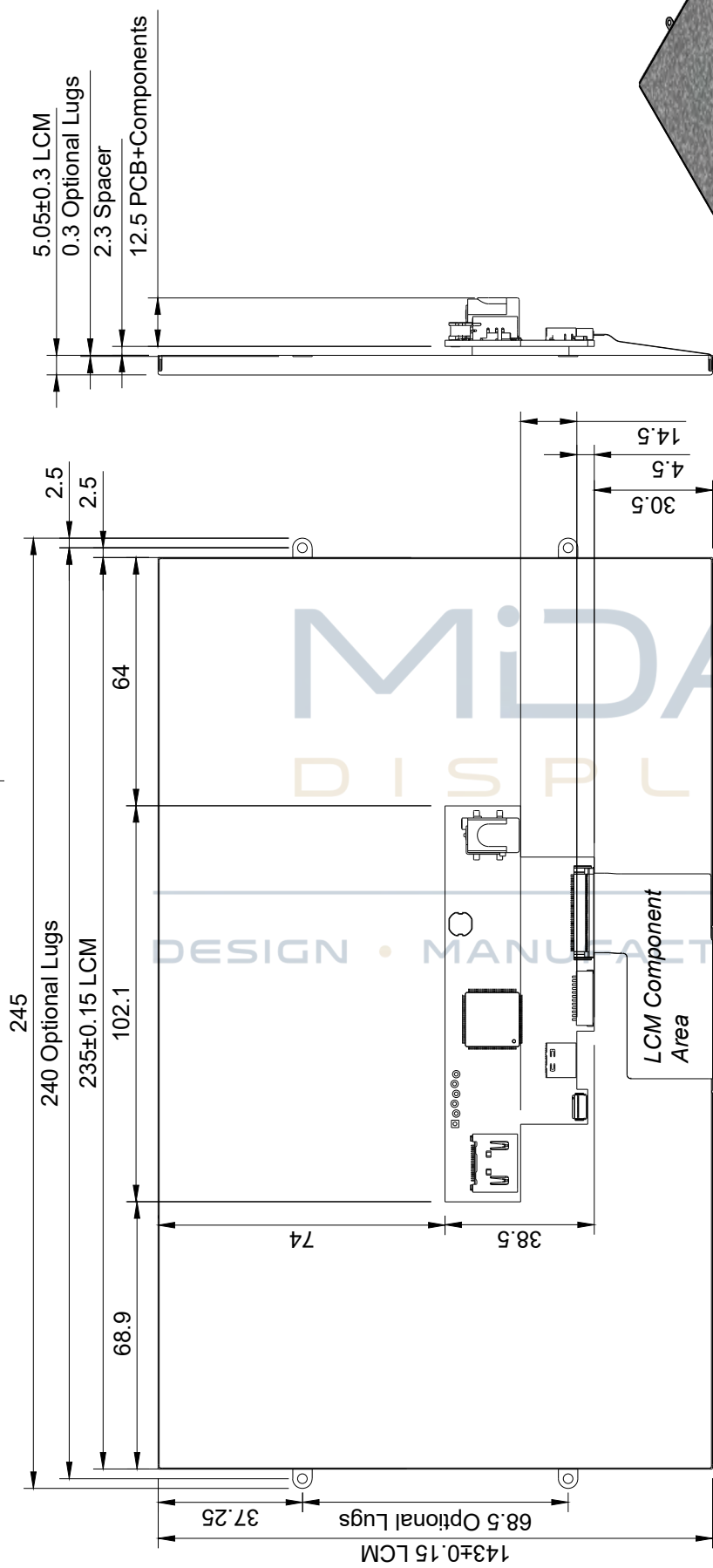
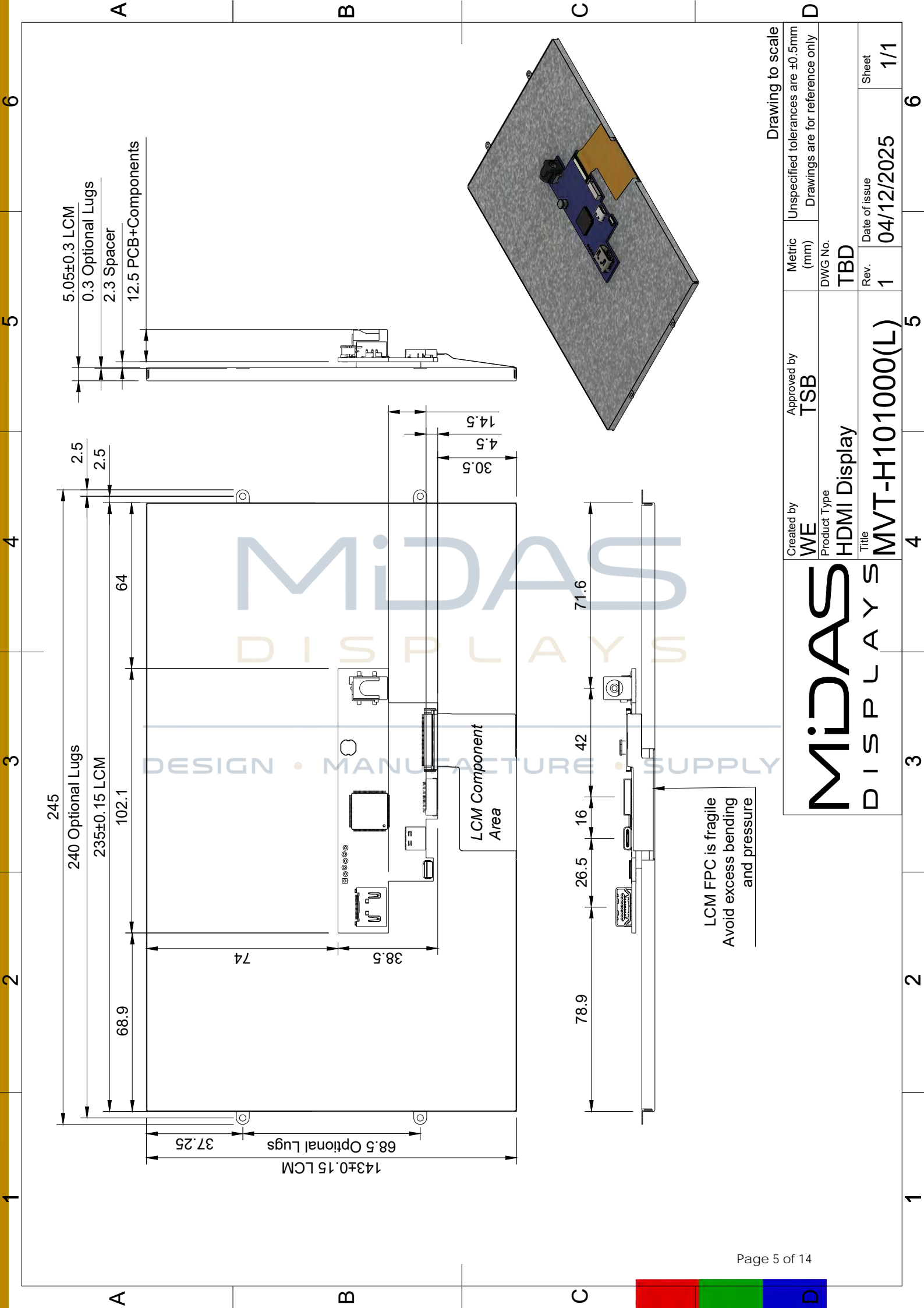

Drawing to scale

Metric (mm)	Unspecified tolerances are ±0.5mm Drawings are for reference only
DWG No.	TBD
Rev.	1
Date of issue	04/12/2025
Sheet	1/1

Created by	WE	Approved by	TSB
Product Type	HDMI Display		
Title	MVT-H101000(L)		

MIDAS
 DISPLAYS

Block Diagram

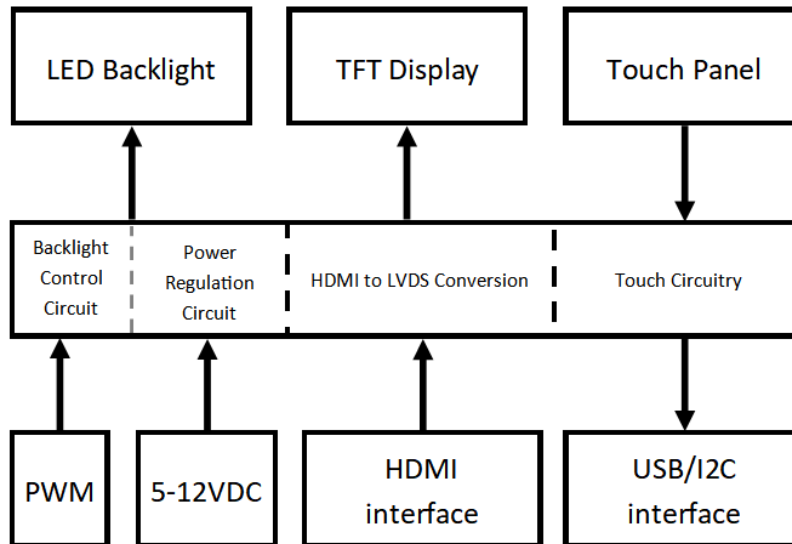

Absolute Maximum Ratings

Parameter	Symbol	Min	Max	Unit
Power Supply Voltage	VDD	+4.7	+14.5	V
Operating temperature	Top	-10	+70	°C
Storage temperature	Tst	-30	+80	°C

Electrical Characteristics

Operating Conditions

Item	Symbol	Min	Typ.	Max	Unit
Power Supply	VDD	5	-	12	V
Logic voltage	Vil	3	3.3	3.6	V
Supply Current 5/12V <i>Checkerboard 100% Brightness</i>	IL	-	1636/630	-	mA

Backlight Conditions

Item	Symbol	Min	Typ.	Max	Unit
PWM Backlight Control	Logic High	-	5	5.5	V
	Logic Low	-0.3	0	-	V
PWM Control Freq.	-	-	1000	-	Hz

Pin Assignment

CN1 – HDMI Type A

Pin No.	Symbol	Description
1	D2+	TMDS Data 2+
2	D2S	TMDS Data 2 shield
3	D2-	TMDS Data 2-
4	D1+	TMDS Data 1+
5	D1S	TMDS Data 1 shield
6	D1-	TMDS Data 1-
7	D0+	TMDS Data 0+
8	D0S	TMDS Data 0 shield
9	D0-	TMDS Data 0-
10	DC+	TMDS Clock+
11	DCS	TMDS Clock shield
12	DC-	TMDS Clock-
13	NC	No Connect
14	NC	No Connect
15	SCL	Serial Clock for EDID
16	SDA	Serial Data for EDID
17	GND	Ground
18	5V HDMI	+5V Power from HDMI host
19	HPD	Hot Plug Detect

CN3 – USB Type C

Pin No.	Symbol	Description
A1/B1	GND	Ground
A4/B4	VBUS	+5V USB Bus power
A5	CC1	Configuration Channel 1
B5	CC2	Configuration Channel 2
A6/B6	D+	USB Data Positive
A7/B7	D-	USB Data Negative
A9/B9	VBUS	+5V USB Bus power
A12/B12	GND	Ground



CN4 – JST SM12B-SRSS-TB-(LF)(SN) (mating part SHR-12V-S-B)

Pin No.	Symbol	Description
1	VBUS	+5V USB Bus power
2	D-	USB Data Negative
3	D+	USB Data Positive
4	GND	Ground
5	GND	Ground
6	SDA	Optional Serial Data for Touch
7	SCL	Optional Serial Clock for Touch
8	3V3	Regulated 3V3 Output
9	/RST	Optional Serial Reset for Touch
10	/INT	Optional Serial Interrupt for Touch
11	BRT+	Brightness increase
12	BRT-	Brightness decrease

CN6 – Barrel Jack

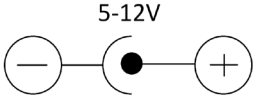
Pin No.	Symbol	Description	Note
1	VIN	5-12V Input	
2	VIN	5-12V Input	
3	GND	Ground	
4	GND	Ground	

J1 – Pin Header

Pin No.	Symbol	Description
1	/MCLR	Programming for PIC16F
2	5V HDMI	+5V Power from HDMI host
3	GND	Ground
4	ICSPDAT	In-Circuit Serial Programming Data for PIC16F
5	ICSPCLK	In-Circuit Serial Programming Clock for PIC16F
6	PWM	Backlight PWM control pin

J2 – Pin Header

Pin No.	Symbol	Description
1	VIN	5-12V Input
2	/PWDN	Power down external control
3	GND	Ground

Solder Links

Link	Description
LK4	Common the HDMI 5V with VIN to power product through HDMI input*
LK11	Common the USB 5V with VIN to power product through USB input*
LK12	Backlight control using internal HDMI Good signal
I2C Touch	Short R7 and disconnect R6 on top right of Touch FPC
USB Touch	Short R6 and disconnect R7 on top right of Touch FPC
*Must not be linked when VIN is used from another connector	



Optical Characteristics

Item	Symbol	Conditions	Specifications			Unit
			Min	Typ.	Max	
Luminance (Without CTP)	L		-	1200	-	cd/m ²
Contrast ratio	CR	$\theta=0^\circ$	-	800	-	
Response time	Rising	Tr	25°C	30	40	ms
	Falling	Tf				
CIE Colour Coordinate	RED	XR	Normal Viewing Angle	+/-0.02	+/-0.02	
		YR				
	GREEN	XG				
		YG				
	BLUE	XB				
		YB				
	WHITE	XW				
		YW				
Viewing Angle	Hor.	θ_{x+}	-	85	-	Degree
		θ_{x-}	-	85	-	
	Ver.	θ_{y+}	-	85	-	
		θ_{y-}	-	85	-	

DESIGN • MANUFACTURE • SUPPLY



Definition of viewing angle θ_x and θ_y :

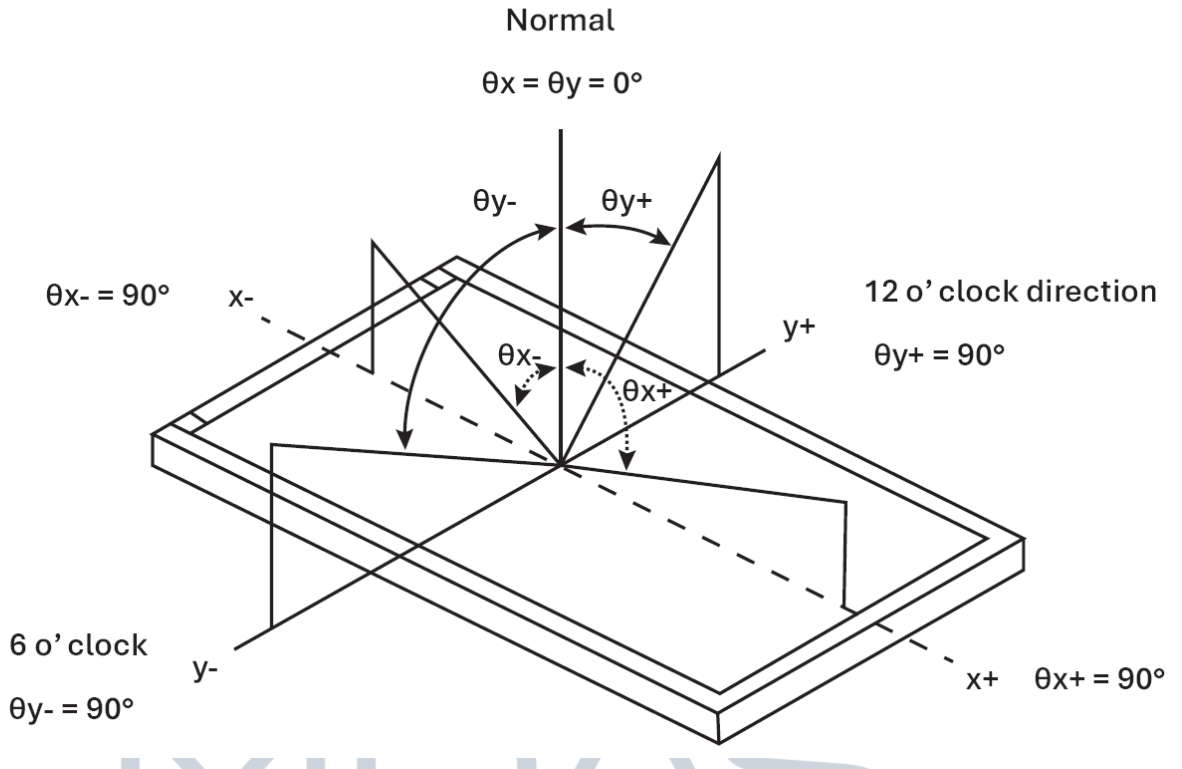

Definition of contrast ratio:

$$CR = \frac{\text{Brightness of non-selected dots (white)}}{\text{Brightness of selected dots (black)}}$$

Definition of response time:

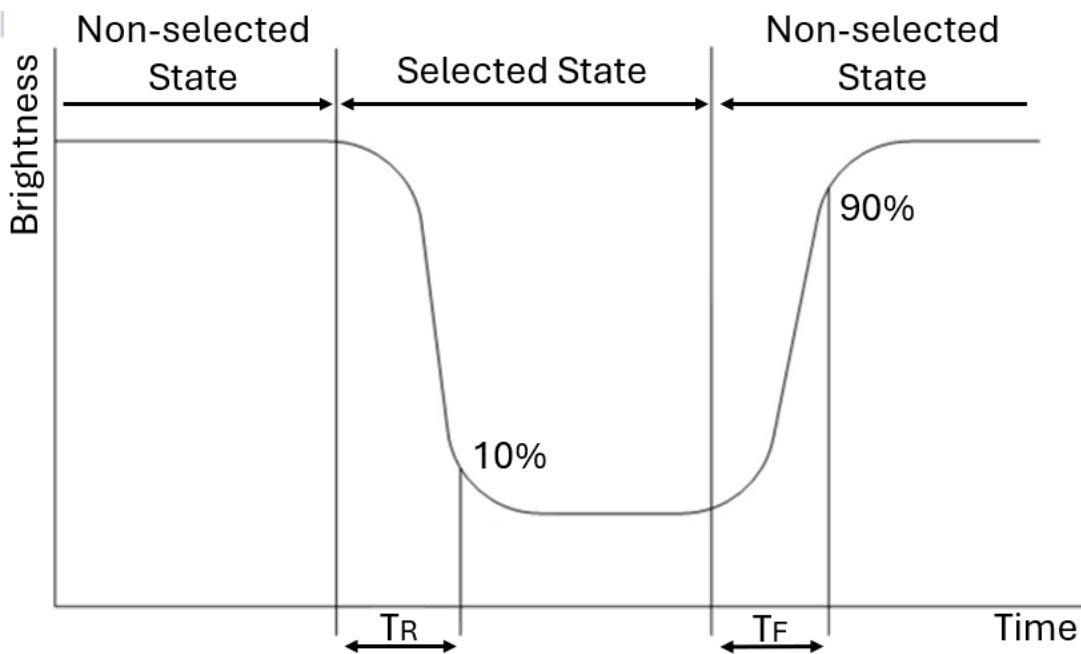

Brightness Test Equipment Setup

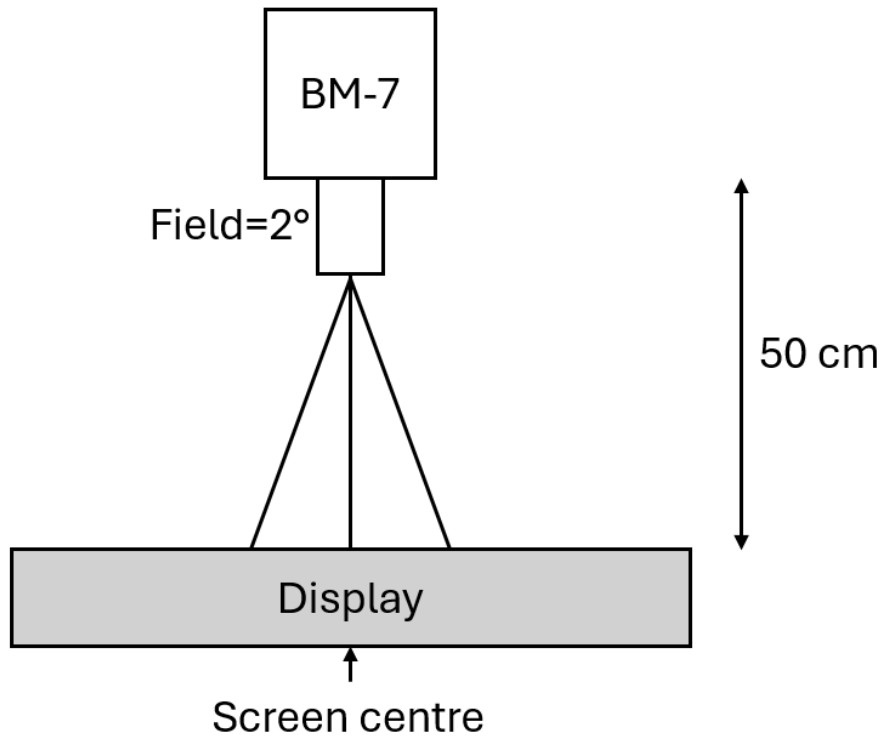

Field = 2° (As measuring "black" image, field = 2° is the best testing condition)

Brightness Test Point Setup

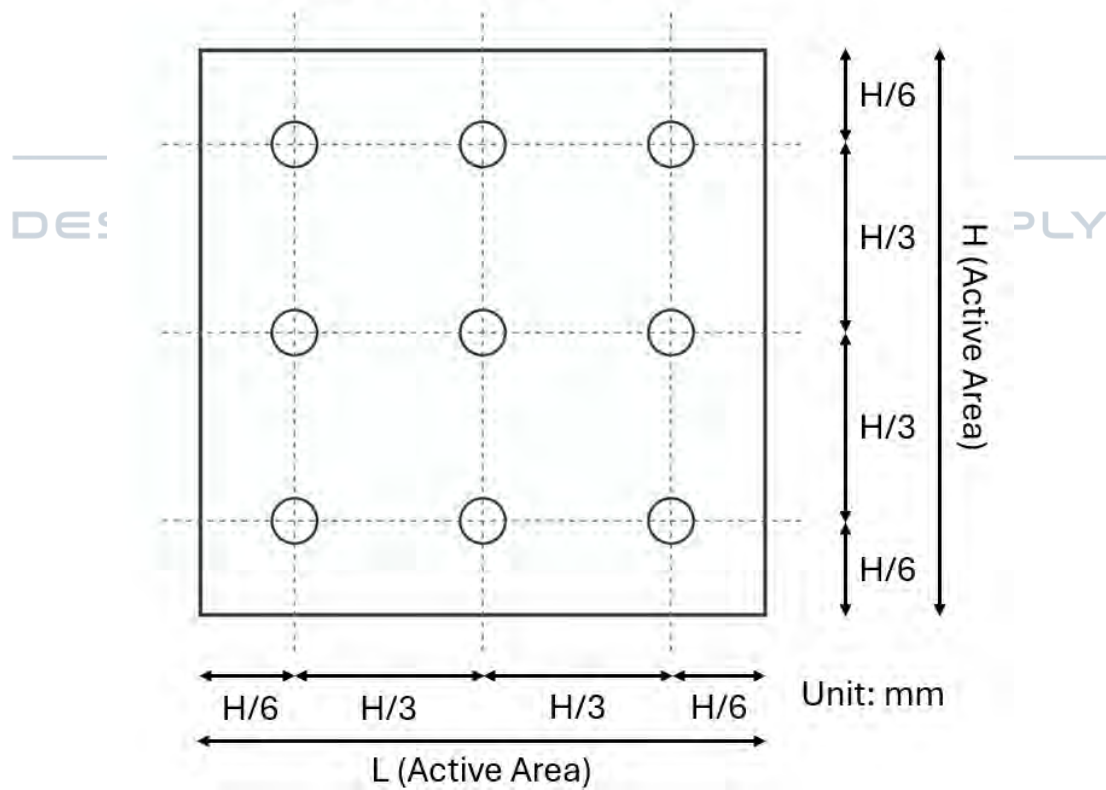

Reliability Test – PENDING

Environmental Item	CONDITIONS	
High Temperature Storage	TA=80°C	96H
Low Temperature Storage	TA=-30°C	96H
High Temperature Operation	TA=70°C	96H
Low Temperature Operation	TA=-10°C	96H
High Temperature and High Humidity Operation	+60°C, 90%RH	96H
Thermal Shock	-30°C →+80°C	0.5H:5CYCLES

MIDAS
DISPLAYS

DESIGN • MANUFACTURE • SUPPLY



Handling Precautions

- The display panel is constructed of glass. Refrain from exposing it to mechanical shock, such as dropping it from a height.
- The display should not be disassembled as this can impact the functionality and invalidate the warranty.
- In the event of damage to the display panel resulting in leakage of the liquid crystal substance, it is imperative not to ingest the substance. If contact occurs with skin or clothing, please wash the affected area thoroughly with soap and water immediately.
- Do not apply excessive force to the display surface or adjoining areas, as this may cause colour tone variations.
- The polariser covering the display surface of the LCD module is soft and easily scratched. Handle this polariser carefully.
- To prevent damage to the elements by static electricity, observe EMI precautions.
- Ensure that the body is grounded when handling the LCD module.
- Tools required for assembly, such as soldering irons, must be properly grounded.
- To reduce the generation of static electricity, avoid conducting assembly and other work under dry conditions.
- The LCD module is coated with a film to protect the display surface. Exercise caution when peeling off this protective film, as static electricity may be generated.
- Use only specific solvents, like Isopropyl or Ethyl alcohol, for cleaning the display. Clean with a soft, clean cloth and avoid submerging the display.
- The removal of the protective tape over components may result in damage or cause detachment from their solder pads.
- To minimise potential performance degradation of the LCD modules due to static electricity or other factors, please exercise caution when handling the modules. Avoid touching the following areas:
 - The exposed sections of the printed circuit board
 - The terminal electrode sections.

Assembly Precautions

- Do not make alterations or modifications to the display, including the glass, printed circuit board, components or FFC/FPC unless advised by Midas as this will invalidate the warranty.
- Solder should only be applied to the specified terminals. For direct solder displays, a hot bar should be used, with 250-300°C for 3-5 seconds.
- The mounting method should not add mechanical stress upon the display.
- Assembling operators should be grounded during the entire process of handling the display. Likewise, any tools, such as soldering irons, should be properly grounded.
- Avoid cleaning solutions from the assembly process, such as solder flux cleaning fluids, from getting onto the display as this can leak into the housing and cause internal damage.
- Assembly should be conducted under ESD safe conditions to reduce the risk of static electricity.
- Continuous high temperatures during assembly may cause deformation or damage.
- Care should be taken when bending the FFC/FPC, as continuous bends may wear out the circuitry.
- The plating of the FFC/FPC can be worn down by multiple insertions.
- Lead free solder should be used to adhere with RoHS



Operation Precautions

- The maximum ratings of the display should never be exceeded, or functionality cannot be guaranteed.
- Sudden shutdown caused by forced removal of the power supply may cause damage to the electronics of the display.
- Temperature and environment can influence the display and electronics, and the display should be tested by the end customer within expected working conditions to check for satisfactory performance.
- The user should implement external over-current and over-voltage protection.
- Do not apply signals to the logic input if the display is not powered
- A constant current source is recommended for the operation of the backlight. Using a constant voltage source without adequate current limitations can permanently damage the backlights operation.
- If the LCD modules have been operating for a long time showing the same display patterns may remain on the screen as ghost images and a slight contrast irregularity may also appear. Abnormal operating status can be resumed to be normal condition by suspending use for some time. It should be noted that this phenomenon does not adversely affect performance reliability.

Others

- Liquid crystals solidify at low temperature (below the storage temperature range) leading to defective orientation of liquid crystal or the generation of air bubbles (black or white). Air bubbles may also be generated if the module is subjected to a strong shock at a low temperature.
- When storing the LCD modules, avoid exposure to direct sunlight or light from fluorescent lamps. Keep the modules in bags designed to prevent static electricity charging under low temperature and normal humidity conditions (avoid high temperature, high humidity, and temperatures below 0°C). Whenever possible, store the LCD modules in the same packaging as when they were shipped from Midas.
- Midas maintains the right to change the passive components, and the PCB revision without informing the customer with the intent to continue supplying the product with the same or better performance.
- This display is supplied as a component for use within a completed assembly. As such it should be tested within the completed unit for suitability. Performance may vary depending on external components.
- This device will have susceptibility to external noise and interference; care should be taken to isolate or shield the product if necessary. Cables may require additional shielding or shortening.
- The disposal of a display should be handled by qualified industrial waste management and is not for standard waste disposal.
- Midas's warranty liability is strictly confined to the repair and replacement of purchased products. Midas shall not be held liable for any consequential damages.
- The warranty period for products sold from Midas Displays is 12 months from dispatch, unless otherwise stated. Terms and conditions apply.

