



Main

Range of product	Zelio Relay
Product or component type	Solid state relay
Provided accessory	Thermal interface
Device short name	SSP1
Mounting support	Panel
Number of phases	1 phase
Contacts type and configuration	1 NO
[In] rated current	25 A
Solid state output type	Zero voltage switching SCR output

Complementary

Control circuit voltage	3...32 V DC
Switching voltage	>= 3 V DC turn-on <= 1 V DC turn-off
Response time	0.5 cycle turn-off 0.5 cycle turn-on
Input current	10 mA at 12 V DC
Output voltage	24...300 V AC
Load current	0.15...25 A
Transient overvoltage	600 V
Surge current	<= 250 A for 16.6 ms
Maximum I ² t for fusing	258 A ² .s for 10 ms at 50 Hz half cycle 259 A ² .s for 8.33 ms at 60 Hz half cycle
Co-ordination type	Type 2 - 20 A miniature circuit breaker (MCB) - curve B Type 1 - 25 A miniature circuit breaker (MCB) - curve B
Leakage current	<= 1 mA off-state
Voltage drop	1.15 V on-state
DV/Dt	500 V/μs off-state at maximum voltage
Power factor	0.5 with maximum load
Motor controller rating	1 hp 240 V AC 0.5 hp 120 V AC
Insulation resistance	1000 MOhm at 500 V DC
Maximum capacitance	10 pF for input/output
Dielectric strength	4 kV AC for input or output to case 4 kV AC for input/output
[Uimp] rated impulse withstand voltage	6 kV output to case
Tightening torque	2...2.2 N.m for output 1.5...1.7 N.m for input
Connections - terminals	Ring lugs : 11.7 x 4.5 mm for output Forked type tag connectors : 11.7 x 4.5 mm for output Ring lugs : 9.2 x 4 mm for input Forked type tag connectors : 9.2 x 4 mm for input Screw terminals : 0.5...8.26 mm ² , (AWG 20...AWG 8) without cable end for output Screw terminals : 0.2...3.3 mm ² , (AWG 24...AWG 12) without cable end for input Screw terminals : 0.5...5.26 mm ² , (AWG 20...AWG 10) with cable end for output Screw terminals : 0.2...3.3 mm ² , (AWG 24...AWG 12) with cable end for input
Thermal resistance	0.8 °C/W junction to case
LED indicator	LED green for input status
IP degree of protection	IP20
Product weight	89.2 g

Environment

Ambient air temperature for operation	-40...80 °C
Ambient air temperature for storage	-40...125 °C
Pollution degree	2
Overvoltage category	III
Product certifications	CE CSA RoHS UL REACH EAC
Marking	CE CSA UL EAC
Standards	EN/IEC 60950-1 UL 508 EN/IEC 62314 CSA C22.2 No 14-13

Dimensions

mm
in.

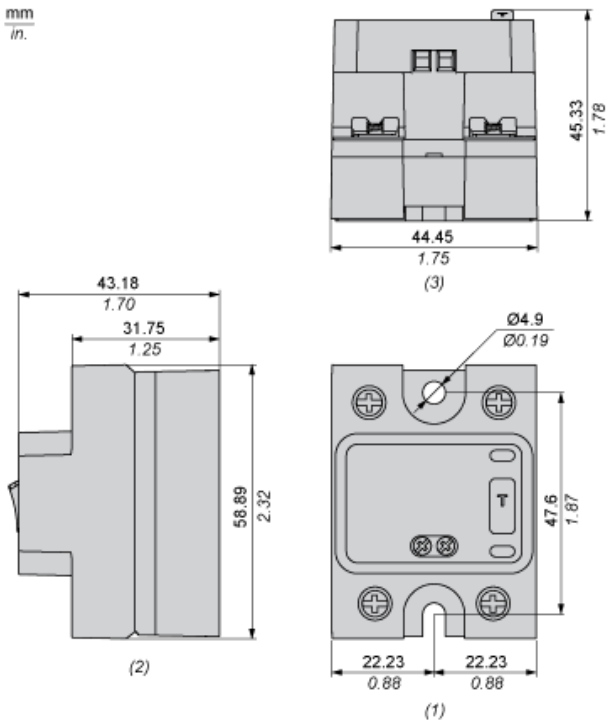

- (1) Front view
- (2) Side view
- (3) Bottom view

Derating Curves

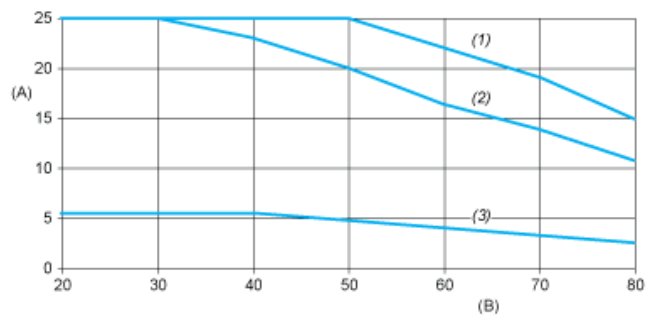

- A : Load Current (Arms)
- B : Ambient Temperature (°C)
- (1) For Heatsink SSRHP17
- (2) For Heatsink SSRHP25
- (3) No Heatsink