



## Main

Range of product	Lexium 23 Plus
Product or component type	Motion servo drive
Device short name	LXM23

## Complementary

Format of the drive	Book
Network number of phases	3 phases Single phase
[Us] rated supply voltage	220 V (- 20...15 %)3 phases 220 V (- 10...15 %)single phase
Supply voltage limits	170...255 V 3 phases 200...255 V single phase
Supply frequency	50/60 Hz (- 5...5 %)
Network frequency limits	47.5...63 Hz
Continuous output current	5.1 A
Continuous power	750 W at 220 V
Nominal power	0.75 kW at 220 V
Leakage current	> 3.5 mA
Output voltage	<= power supply voltage
Electrical isolation	Between power and control
Type of cable	Twisted shielded pairs cable (single or double) at 0...55 °C
Electrical connection	Terminal 2.1 mm <sup>2</sup> / AWG 14 (PA/+, PBe) Terminal 0.82 mm <sup>2</sup> / AWG 18 (U, V, W) Terminal 2.1 mm <sup>2</sup> / AWG 14 (R, S, T) Terminal 1.3 mm <sup>2</sup> / AWG 16 (L1-L2)
Tightening torque	1.4 N.m (PE (ground))
Discrete input number	8 programmable
Discrete input type	Programmable (CN1)
Discrete input voltage	12...24 V DC logic
Discrete input logic	Positive or negative logic (CN1)
Discrete output number	5
Discrete output type	(CN1)Logic output 12...24 V DC
Discrete output voltage	12...24 V DC
Discrete output logic	Positive or negative logic (CN1)
Analogue input number	2
Absolute accuracy error	0.01 %
Analogue input type	Voltage analog input (T_REF)- 10...10 V input impedance: 10 kOhm Voltage analog input (V_REF)- 10...10 V input impedance: 10 kOhm
Control signal type	Servo motor encoder feedback

Protection type	Abnormal pulse control command for drive Overspeed for motor Overload for motor Overheating for motor Undervoltage for motor Overvoltage for motor Overcurrent for motor Against short-circuits for outputs signal Against reverse polarity for inputs signal
Communication interface	Integrated Modbus
Type of connector	RJ45 (CN3) for Modbus
Method of access	Slave
Physical interface	2-wire RS485 multidrop for Modbus
Transmission rate	Configurable
Status LED	1 LED function: charge LED
Signalling function	Servo status and fault codes for five 7-segment display units
Marking	CE
Type of cooling	Integrated fan
Operating position	Vertical
Width	85 mm
Height	162 mm
Depth	180 mm
Product weight	2.2 kg

## Environment

EMC filter	Without EMC filter
Electromagnetic compatibility	Conducted and radiated emissions with additional EMC filter conforming to EN/IEC 61800-3 environments 1 and 2 category C2, C3 EMC immunity (level 4) conforming to EN/IEC 61000-4-4 EMC immunity (level 3) conforming to EN/IEC 61000-4-5 EMC immunity (level 3) conforming to EN/IEC 61000-4-3 EMC immunity (level 3) conforming to EN/IEC 61000-4-2 EMC immunity with additional EMC filter conforming to EN/IEC 61800-3 environments 1 and 2
Standards	EN/IEC 61800-5-1
Product certifications	C-Tick CULus 508
IP degree of protection	IP41 for on upper part with protective cover IP20 for on upper part without protective cover
Vibration resistance	1 gn (f = 57...150 Hz) conforming to IEC 60068-2-6 0.075 mm peak to peak (f = 10...57 Hz) conforming to IEC 60068-2-6
Shock resistance	15 gn for 11 ms conforming to IEC 60068-2-27
Relative humidity	Class 3K3 (5 to 85 %) without condensation or dripping water conforming to IEC 60721-3-3
Ambient air temperature for operation	0...55 °C conforming to UL
Ambient air temperature for storage	-20...65 °C
Operating altitude	> 1000...2000 m with continuous power derating of 1 % per 100 m <= 1000 m without derating

Dimensions

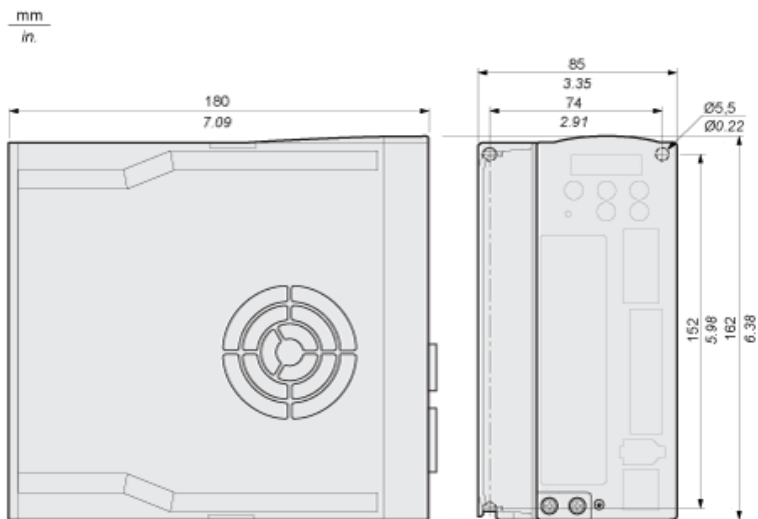

Mounting Recommendations

Mount the device in a vertical position ( $\pm 10^\circ$ ). This is required for cooling the device.

Clearance

Many Devices in a cabinet

$\frac{\text{mm}}{\text{in.}}$

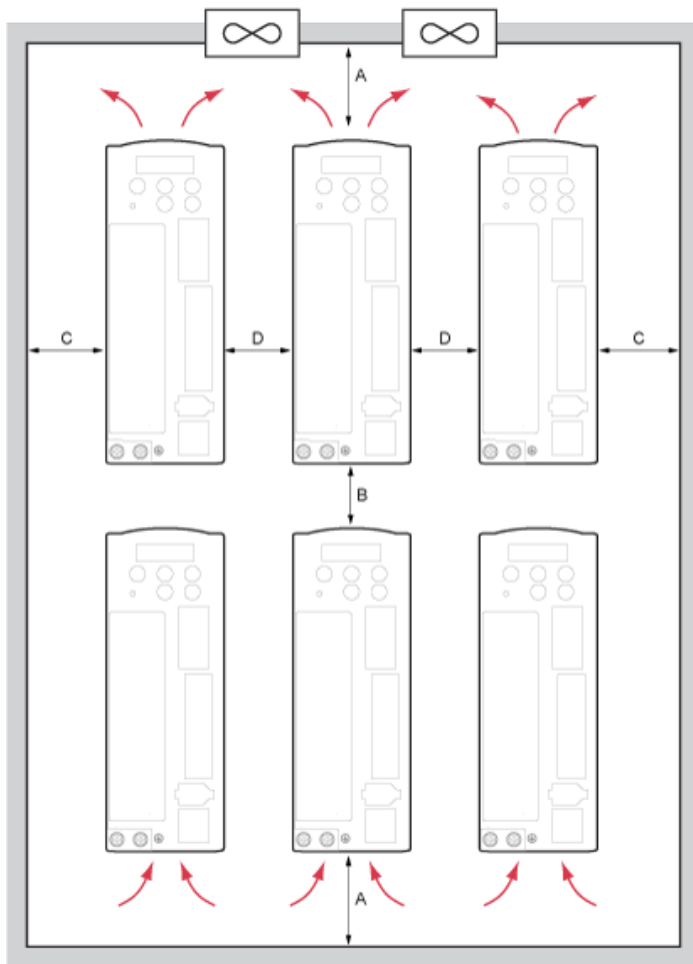

A $\geq 100$ mm ( $\geq 4$ in.)	Free space above/below devices
B $\geq 80$ mm ( $\geq 3.2$ in.)	Free space between devices
C $\geq 40$ mm ( $\geq 1.6$ in.)	Free space between devices and cabinet
D $\geq 10$ mm ( $\geq 0.4$ in.)	Free space between devices

One Device in a cabinet

$\frac{\text{mm}}{\text{in.}}$

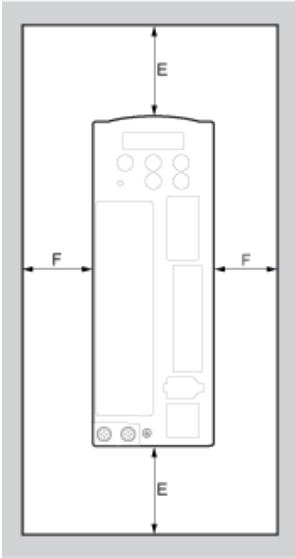

$E \geq 50 \text{ mm} (\geq 2 \text{ in.})$	Free space above/below the device
$F \geq 20 \text{ mm} (\geq 0.8 \text{ in.})$	Free space between device and cabinet

Position Control Mode Wiring Diagram (Pulse Control)

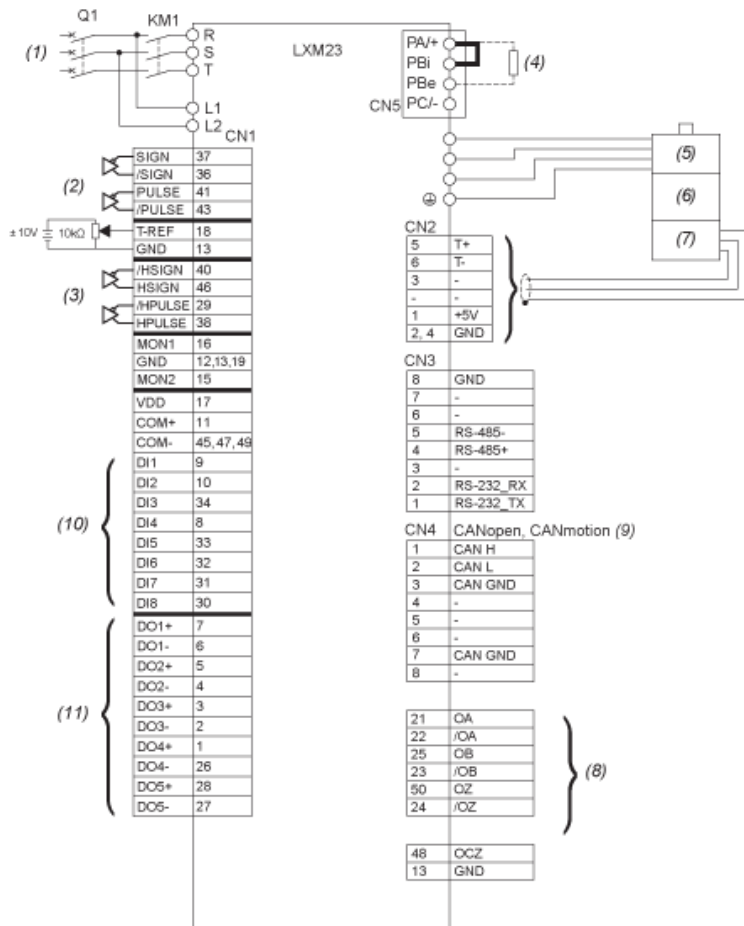

- KM1 Line Contactor
- Q1 Circuit breaker
- (1) AC 220 / 230 V Single Phase or Three Phase 50 / 60 Hz
- (2) Pulse Input (Line Driver)
- (3) High-Speed Pulse Input (Line Receiver)
- (4) External Braking Resistor
- (5) Power Supply
- (6) Holding Brake
- (7) Encoder
- (8) Encoder Pulse Output
- (9) Only LXM23A models
- (10) Digital inputs
- (11) Digital outputs

Position Control Mode Wiring Diagram (Build-In Motion Sequence)

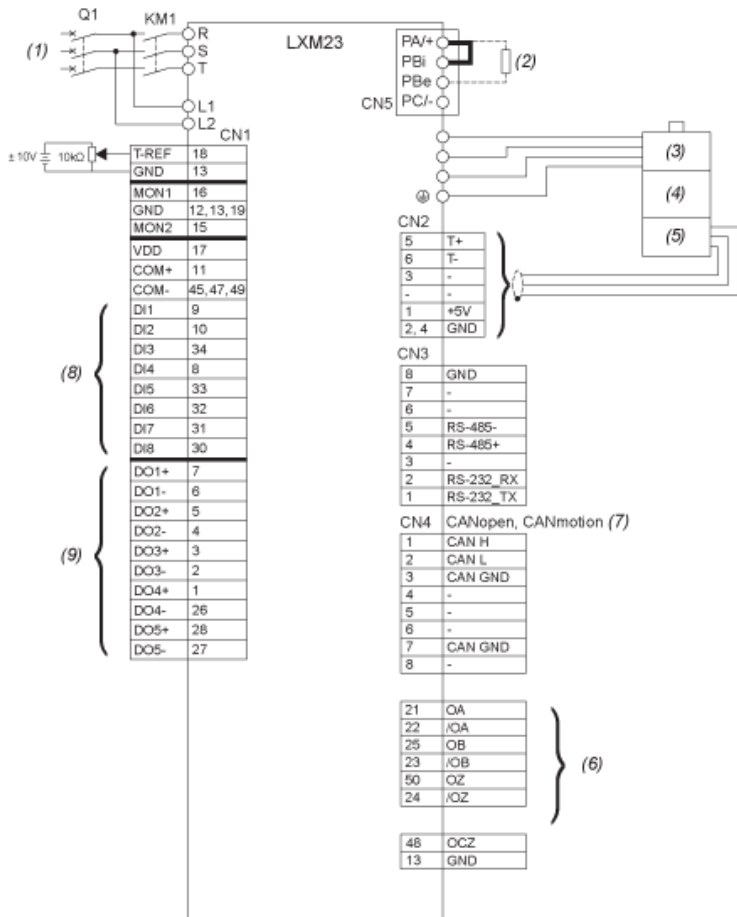

- KM1 Line Contactor
- Q1 Circuit breaker
- (1) AC 220 / 230 V Single Phase or Three Phase 50 / 60 Hz
- (2) External Braking Resistor
- (3) Power Supply
- (4) Holding Brake
- (5) Encoder
- (6) Encoder Pulse Output
- (7) Only LXM23A models
- (8) Digital inputs
- (9) Digital outputs

### Speed Control Mode Wiring Diagram

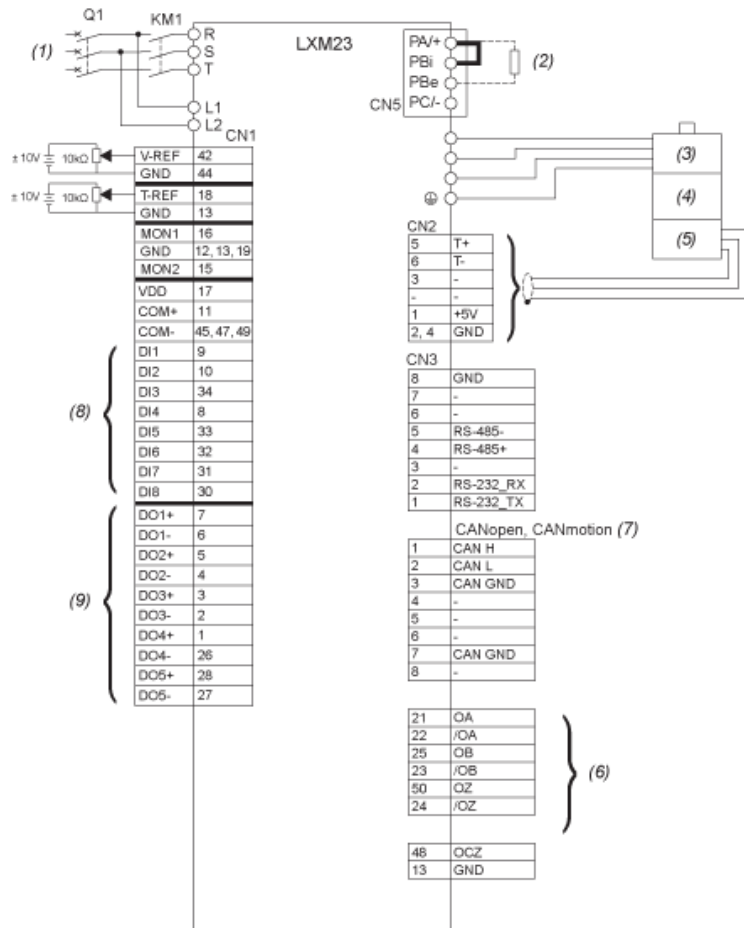

- KM1 Line Contactor
- Q1 Circuit breaker
- (1) AC 220 / 230 V Single Phase or Three Phase 50 / 60 Hz
- (2) External Braking Resistor
- (3) Power Supply
- (4) Holding Brake
- (5) Encoder
- (6) Encoder Pulse Output
- (7) Only LXM23A models
- (8) Digital inputs
- (9) Digital outputs

## Torque Control Mode Wiring Diagram



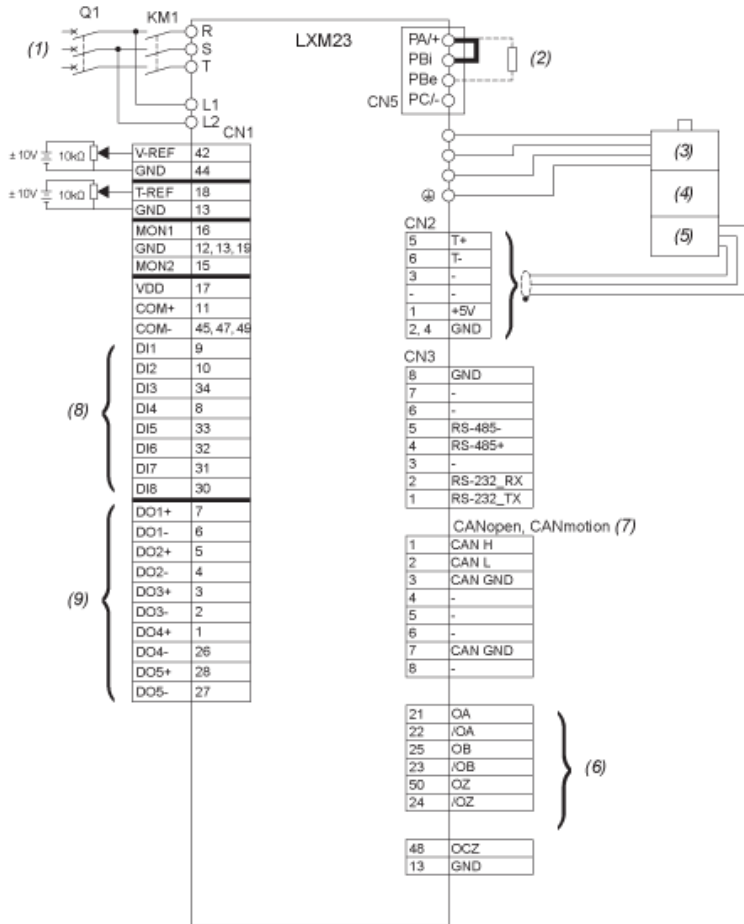

- KM1 Line Contactor
- Q1 Circuit breaker
- (1) AC 220 / 230 V Single Phase or Three Phase 50 / 60 Hz
- (2) External Braking Resistor
- (3) Power Supply
- (4) Holding Brake
- (5) Encoder
- (6) Encoder Pulse Output
- (7) Only LXM23A models
- (8) Digital inputs
- (9) Digital outputs