

The Cable Assembly Work Instruction

装配作业指导书

--For UPC Inline Type Plug Connector

--UPC直头插头连接器

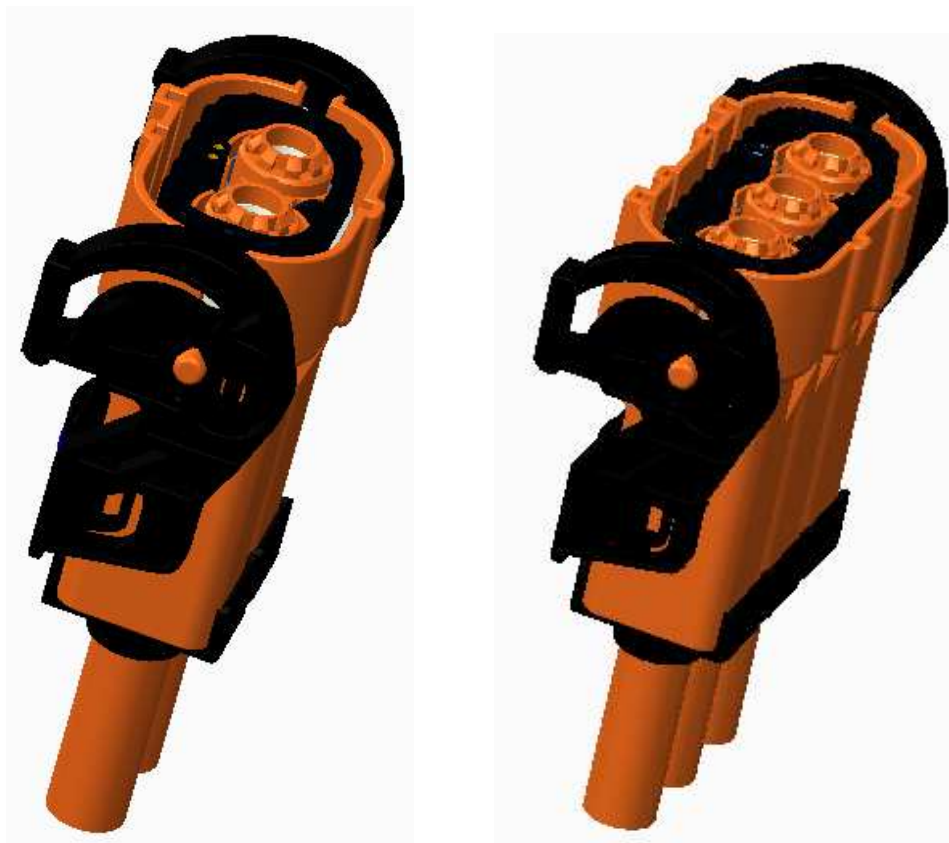

Part 1: Package contents

第一部分：包装清单

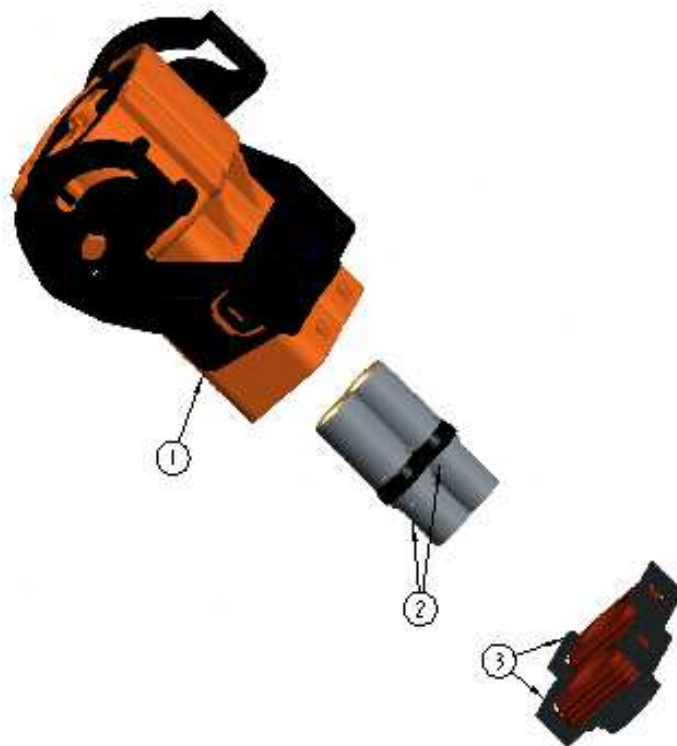

① : Plug housing sub ass. 插头壳体组件

② : Socket Contact sub ass. 端子组件

③ : Cable gland 线缆密封组件

Part 2: 2 ports plug assembly

第二部分：2芯插头组装

Step1 : Go the cable through the grommet and cap

步骤1：将线缆穿过尾部密封件

The location of the grommet and cap can be free

密封圈和盖子的位置可以是自由的

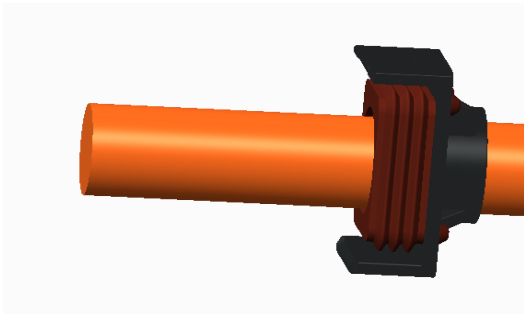

Step 2: Wire cutting and stripping

步骤2：裁剪和剥皮

2-1 50 mm² shielded wire cutting and stripping
50 mm²屏蔽线的裁剪和剥皮

Stripping jacket: 30±1mm Stripping conductor: 14±1mm

护套剥线长度：30±1mm 导体剥线长度：14±1mm

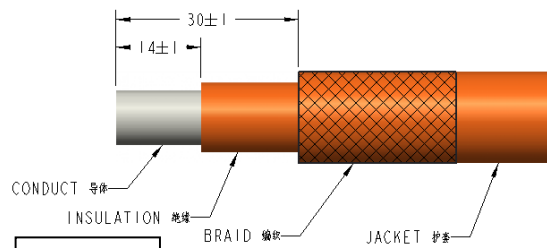

50 mm²

2-2 35 mm²/25 mm² shielded wire cutting and stripping
35 mm²/25 mm²屏蔽线的裁剪和剥皮

Stripping jacket: 20±1mm Stripping conductor: 14±1mm

护套剥线长度：20±1mm 导体剥线长度：14±1mm

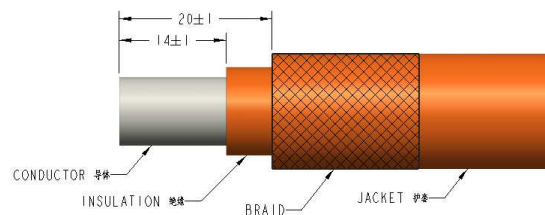

35 mm²/25 mm²

Step 3: Crimping the contact lug to the wire

步骤3：将端子线耳压接到线缆上

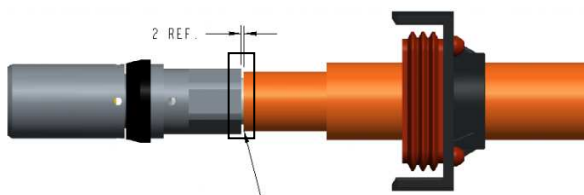

50 mm²

Be sure to be closely in here

确保此处要贴紧，压紧后小于2mm

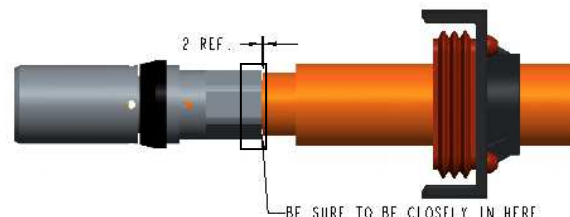

35 mm²/25 mm²

BE SURE TO BE CLOSELY IN HERE

确保贴紧

Be sure to be closely in here

确保此处要贴紧压紧后小于2mm

Crimping tool: Hydraulic press

压接工具：油压机

Die: 50mm²/35 mm²/25 mm²

压模：50mm²/35 mm²/25 mm²

50mm² Die REF.
50mm²压模参考尺寸

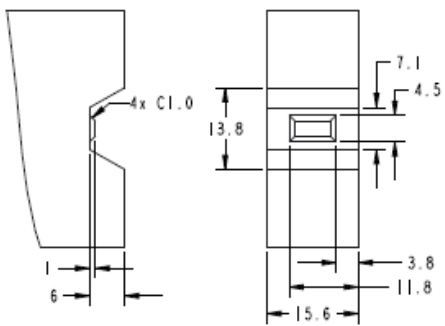

35mm² Die REF.
35mm²压模参考尺寸

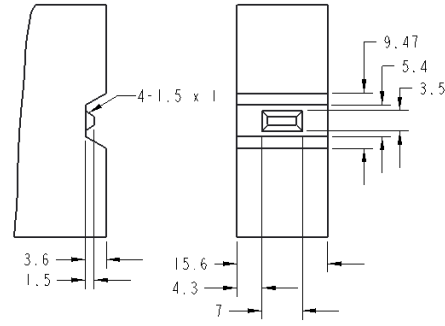

25mm² Die REF.
25mm²压模参考尺寸

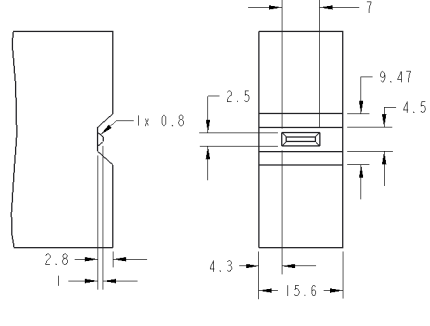

Step 4: (1-1) Install the first Heat Shrink Tubing to the area where crimping contact and wire, and braid need to back off,

(1-2) Braid need to front off, install the second Heat Shrink Tubing to the Braid Then the braid need to back off,

步骤4：(1-1)将第一段热缩管装在端子与线压接的地方,编织带需要往后折

(1-2)将编织带往前折,把第二段热缩管装在编织上,然后再把编织带往后折

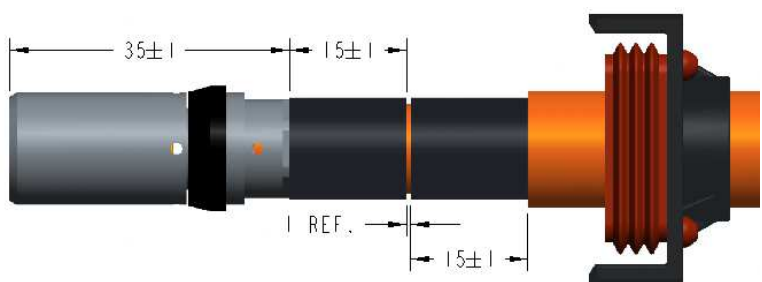

The heat shrinkable tube 15mm,
热缩管长15mm

Amphenol P/N: CH53X-008-09A
安费诺料号: CH53X-008-09A

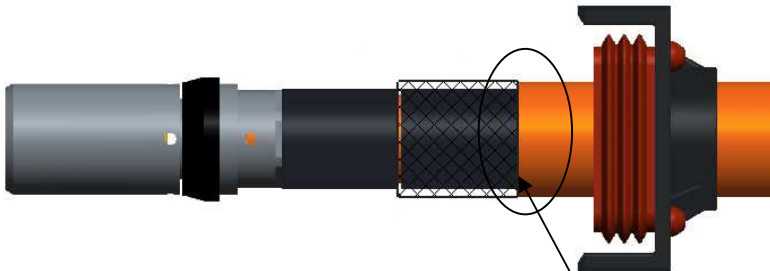

50 mm²

Need to cut the extra shield after assembly
组装后需将多余屏蔽层剪掉

(2-1) Install the first Heat Shrink Tubing to the area where crimping contact and wire, and braid need to back off,

(2-2) Braid need to front off, install the second Heat Shrink Tubing to the jacket Then braid need to back off,

(2-1)将第一段热缩管装在端子与线压接的地方,编织带需要往后折

(2-2)将编织带往前折,把第二段热缩管放在护套前端,然后再把编织带往后折

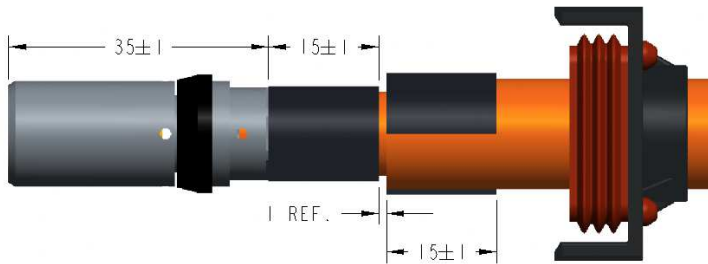

The heat shrinkable tube 15mm,
热缩管长15mm

Amphenol P/N: CH53X-008-09A
安费诺料号: CH53X-008-09A

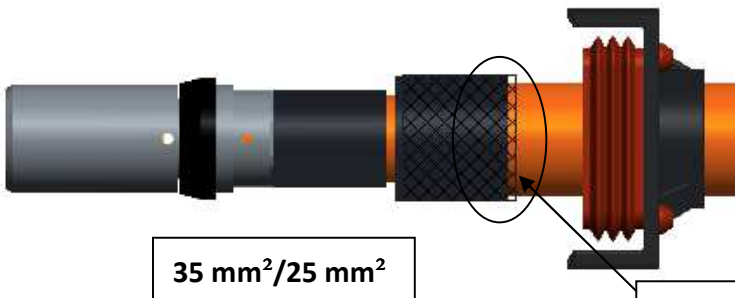

Need to cut the extra shield after assembly
组装后需将多余屏蔽层剪掉

Recommend Heat Shrink Tubing spec.:

热缩管规格推荐:

- ◆ Heat Shrink Tubing OD: 20mm
热缩管OD: 20mm
- ◆ Excellent sealing and insulation properties
良好的密封性和绝缘性能
- ◆ Shrink ratio: 2:1
收缩比: 2:1
- ◆ Operating temperature: -55~125°C
工作温度: -55~125°C

Notes :

注意：

Don't let the shrink tubing cover the braid

不能让热缩管覆盖住屏蔽编织带

50mm² wire cable only needs the first stage heat shrinkable tube

50mm²线只需要第一段热缩管。

Need to do Insulation Resistance and DWV test after cable assembly

在线缆装好后需要做绝缘电阻和耐压测试

Insulation Resistance test: 1000V, 500MΩ Min, 60s

绝缘电阻测试：1000V, 500MΩ Min, 60s

DWV test: 3000V AC, leakage current ≤5mA, 60s

耐压测试：3000V AC, 漏电流≤5mA, 60s

Step 5: Insert the cable assembly into the plug shell assembly

步骤5：将线缆组件插入插头壳体组件中

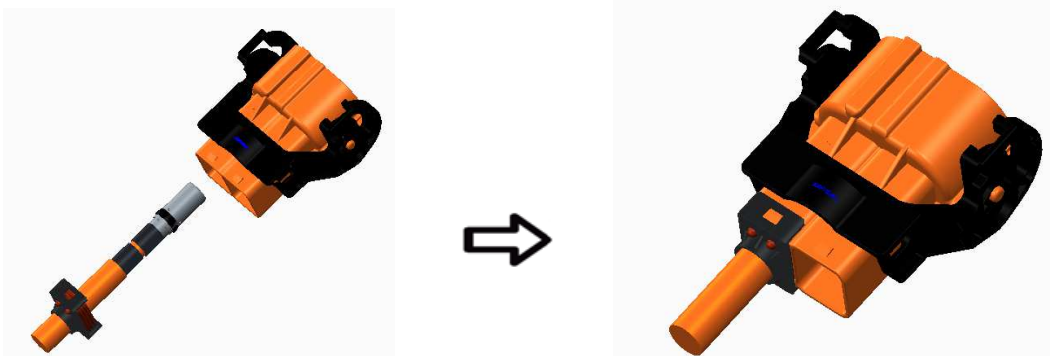

Step 6: Repeat step 1 to step 6 for another port.

步骤6：重复步骤1~5，装另一边

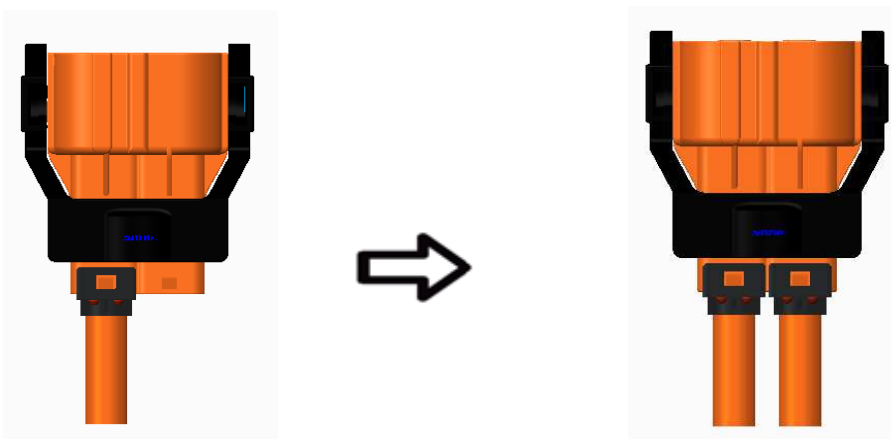

Part 3: 3 ports plug assembly

第三部分：3芯插头组装

3 ports plug connector is the same as 2 ports except more than a port, Step 5 installed intermediate cable assembly first, then install on both sides.

3芯插头和2芯的安装方法是一样的,除了多1芯,另步骤5先安装中间线缆组件,再安装两边



Part 4: Plug and Receptacle Mating and Unmating

第四部分：插头和插座的配合和分离

Mating:

配合：

Unmating:

分离：

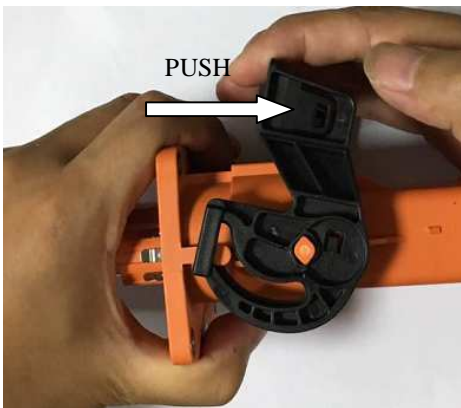

2 Ports

3 Ports