

POWER-LOCK FASTENER N 30

Article Nr. 21.0033/0

[See the product on the website](#) →

[Download CAD Files](#) →

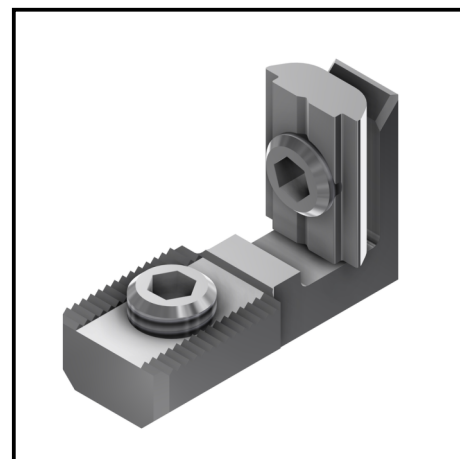
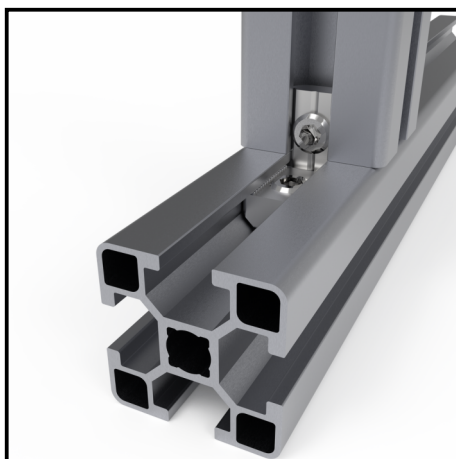
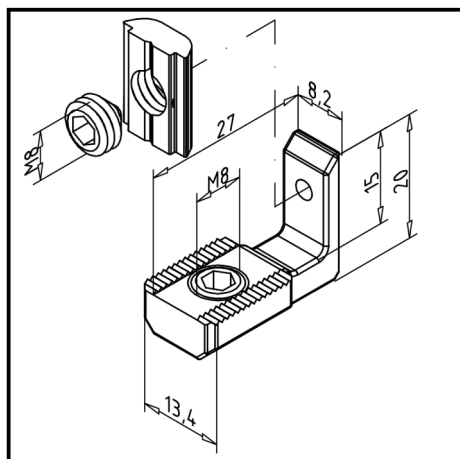

TECHN. DATA / ITEMS SUPPLIED

- Steel, galvanized
- Connection element with pre-assembled threaded pin M8
- 1 Slide nut M8 with pre-assembled setscrew
- Weight = 0.023 kg/piece

APPLICATIONS

- For force-locked connection
- Especially for post-mounting of additional profiles in existing constructions

ASSEMBLY

- Position the profile with the connector
- Swing in and tighten sliding nut with threaded pin
- Tighten set screw of fastener
- Tighten both threaded pins with SW 4 and with 10 Nm torque