









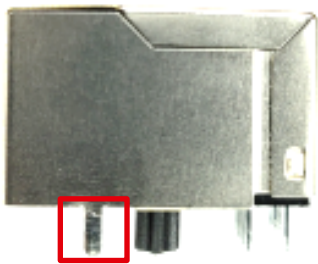

Product/Process Change Notice (PCN)																						
<input checked="" type="checkbox"/> Major Change <input type="checkbox"/> Minor Change																						
PCN Number: PCN_UtRJ45LAN_20250730 Affected Series: WE-RJ45LAN Affected Part Number: see table below PCN Date: 2025-04-30 (YYYY-MM-DD) Effective Date: 2025-07-30 (YYYY-MM-DD)	Change Category: <input type="checkbox"/> Equipment/Location <input checked="" type="checkbox"/> General Data <input checked="" type="checkbox"/> Material <input checked="" type="checkbox"/> Process <input checked="" type="checkbox"/> Product Design <input type="checkbox"/> Shipping/Packaging <input type="checkbox"/> Supplier <input type="checkbox"/> Software																					
Contact: Product Management Phone: +49 (0) 7942 - 945 5001 Fax: +49 (0) 7942 - 945 5179 E-Mail: pcn.eisos@we-online.com	Datasheet Change: <input checked="" type="checkbox"/> Yes <input type="checkbox"/> No Attachment: <input type="checkbox"/> Yes <input checked="" type="checkbox"/> No																					
DESCRIPTION OF CHANGE: <p>In order to enhance the product reliability, Würth Elektronik eiSos will implement a new spot welding design technology. Along with this, further general improvements are done in design and process, like shield plating or wire to shield insulation.</p> <p>There will be no change in fit or function of the product.</p> <p>The new revision of the affected part numbers will be sent out after the previous revision is out of stock (according to FIFO - first-in, first-out).</p> <p>The preliminary datasheets of the affected part numbers which are available in the online catalogue will be available on the website after the PCN date. Link to the website: WE-LAN-RJ45</p>																						
PART NUMBER, REVISION & DATASHEET: <table border="1" style="width: 100%; border-collapse: collapse; margin-top: 5px;"> <thead> <tr> <th style="width: 30%;">Part Number</th> <th style="width: 35%; color: red;">Revision before change</th> <th style="width: 35%; color: green;">Revision after change</th> </tr> </thead> <tbody> <tr> <td>7499031001A</td> <td>002.000</td> <td>003.000</td> </tr> <tr> <td>7499031120A</td> <td>002.001</td> <td>003.000</td> </tr> <tr> <td>7499131001A</td> <td>002.000</td> <td>003.000</td> </tr> <tr> <td>7499131003</td> <td>001.000</td> <td>002.000</td> </tr> <tr> <td>7499131440</td> <td>002.000</td> <td>003.000</td> </tr> <tr> <td>S20100136</td> <td>001.000</td> <td>002.000</td> </tr> </tbody> </table>		Part Number	Revision before change	Revision after change	7499031001A	002.000	003.000	7499031120A	002.001	003.000	7499131001A	002.000	003.000	7499131003	001.000	002.000	7499131440	002.000	003.000	S20100136	001.000	002.000
Part Number	Revision before change	Revision after change																				
7499031001A	002.000	003.000																				
7499031120A	002.001	003.000																				
7499131001A	002.000	003.000																				
7499131003	001.000	002.000																				
7499131440	002.000	003.000																				
S20100136	001.000	002.000																				
<p>The links in the table above are valid until the effective date.</p>																						

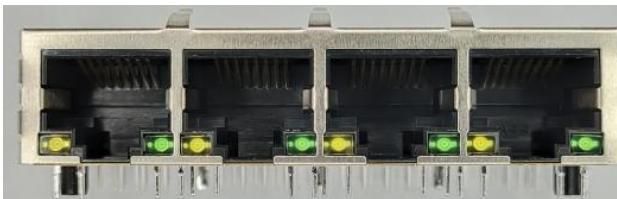
DETAILS OF CHANGE:	
BEFORE CHANGE	AFTER CHANGE
Affected P/N: 7499031001A	
Front View	
	
Changed metal shield's pin from pre-plating process to post-plating process	
	
Affected P/Ns: 7499031120A, 7499131440, S20100136	
EMI fingers are more curved for improved handling	
	
Changed metal shield's pin from pre-plating process to post-plating process	
	

Affected P/Ns: 7499131003, 7499131001A

EMI fingers are more curved for improved handling

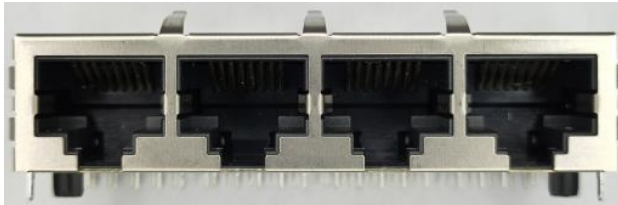

Changed metal shield's pin from pre-plating process to post-plating process

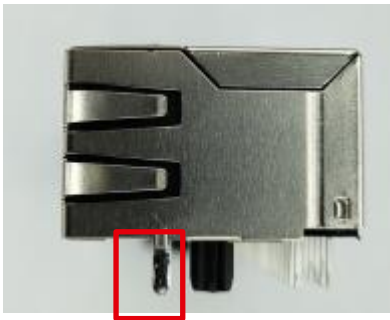

Affected P/Ns:

7499131003, 7499131440, 7499131001A, 7499031001A, 7499131120, 7499031120A, S2010013

Material of plastic insert changed from PBT to PA66

Change of inner Pin design



Affected P/Ns: 7499131003, 7499031001A

Change from THT capacitor to SMT capacitor



Affected P/N: 7499031120A

Inner Structure

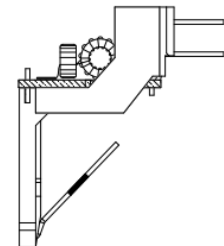
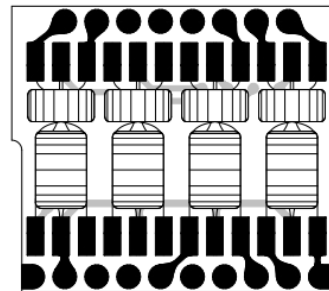
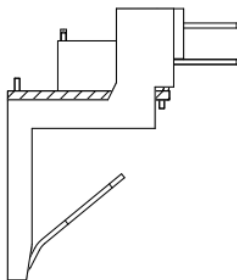
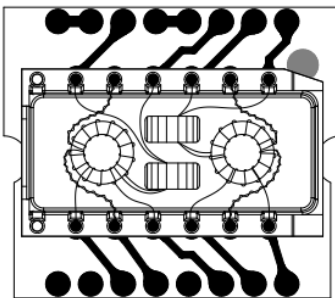

Affected P/Ns: 7499131003, 7499131440, 7499131001A, 7499031001A

Inner Structure

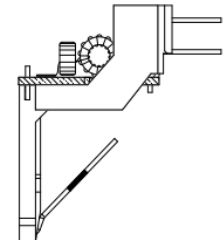
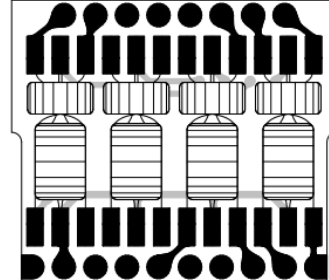
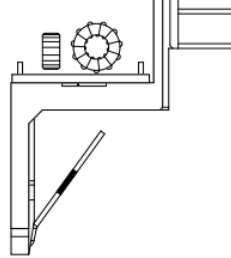
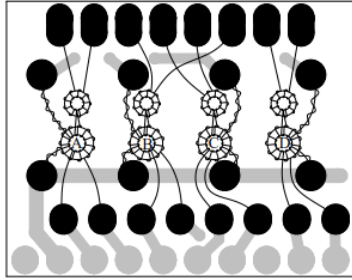



Datasheet correction:

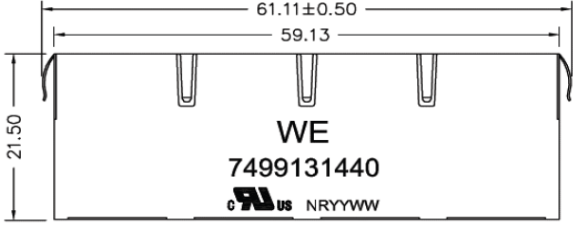
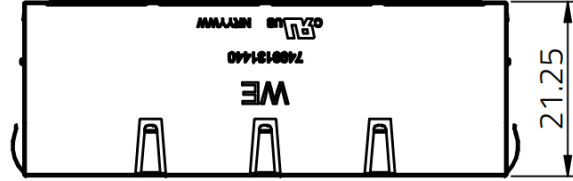
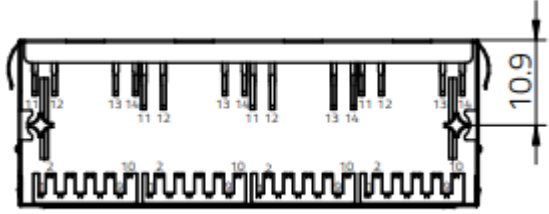
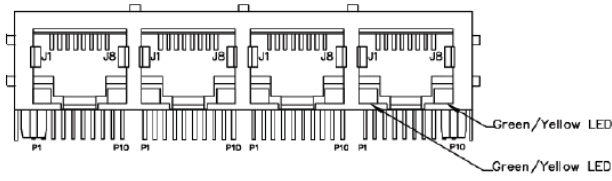
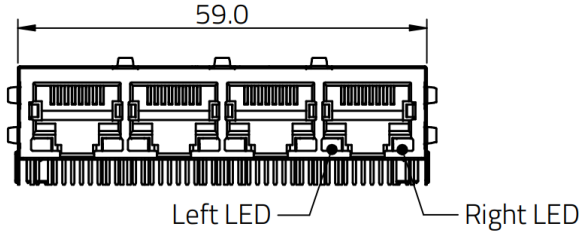
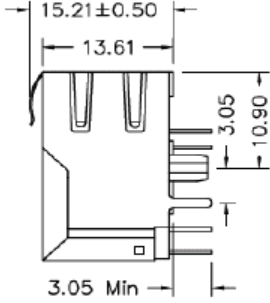
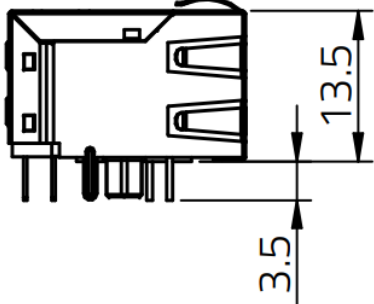

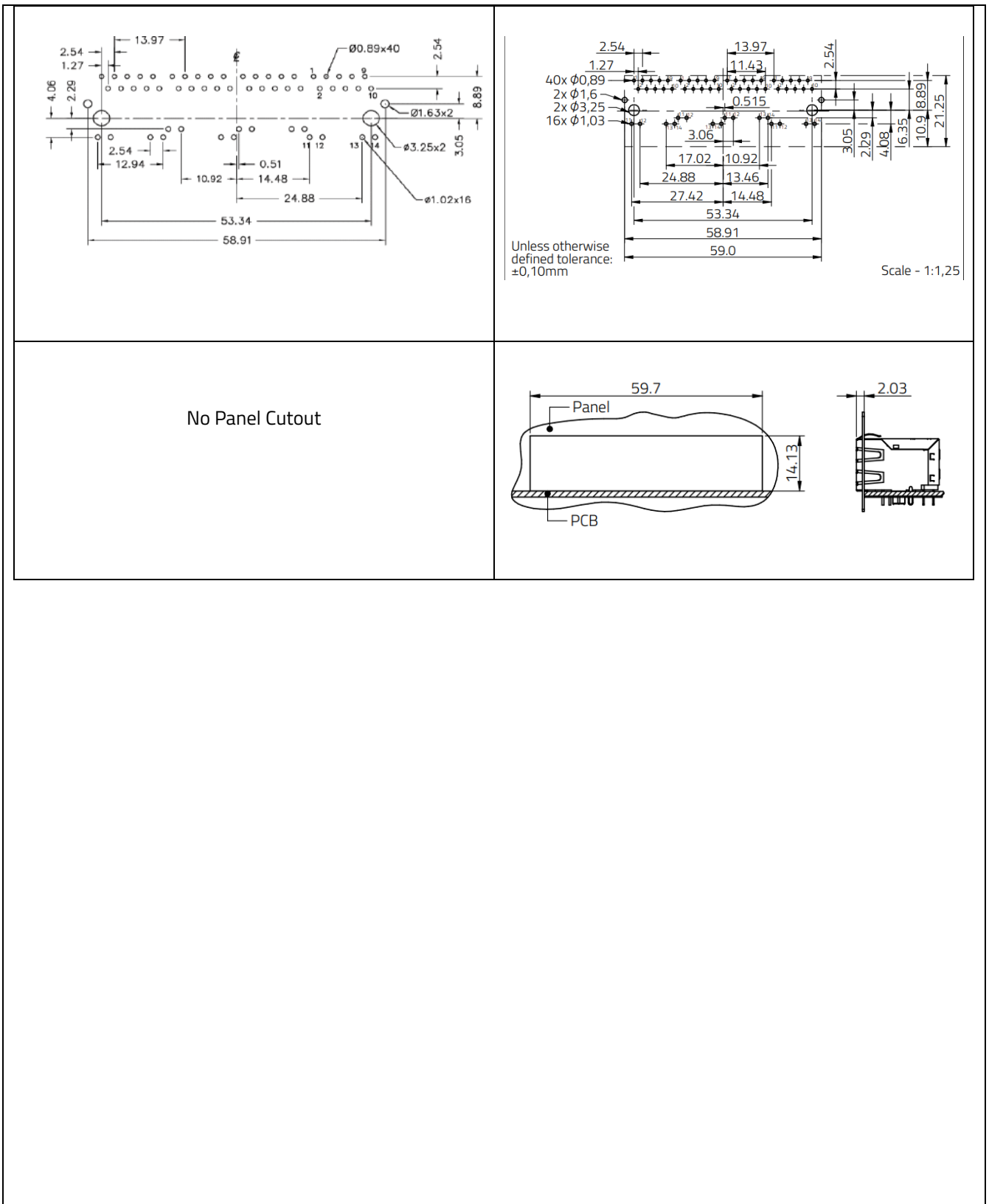
Affected P/N: 7499131440

Before Correction	After Correction
	
<p>No bottom view</p>	
	
	

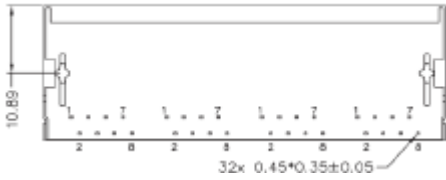
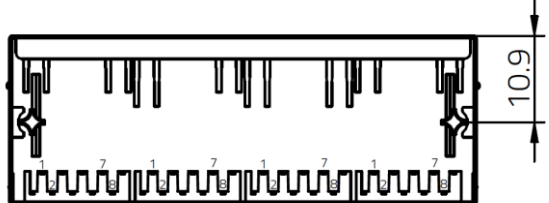
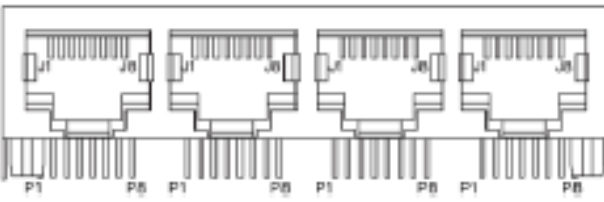
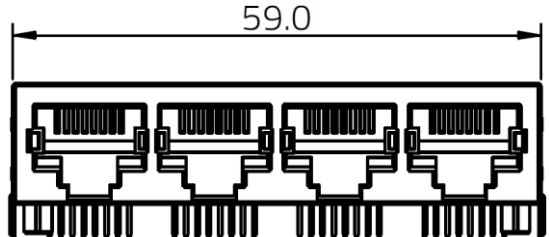
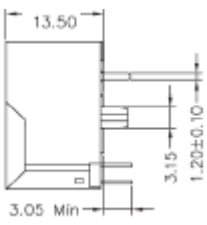
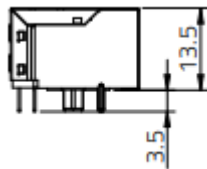

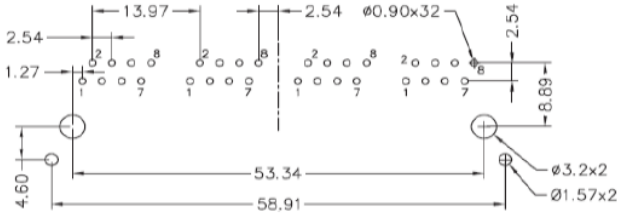
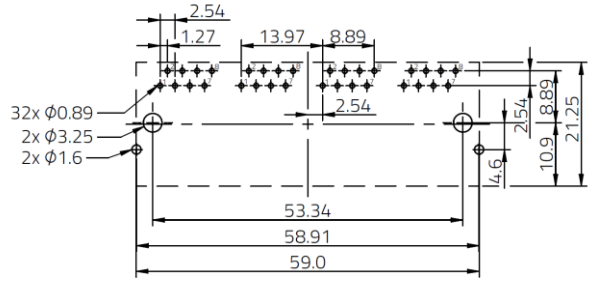
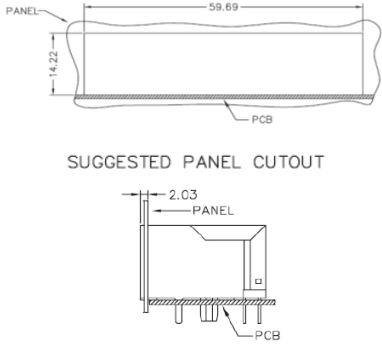
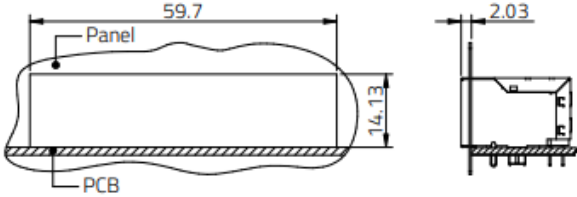

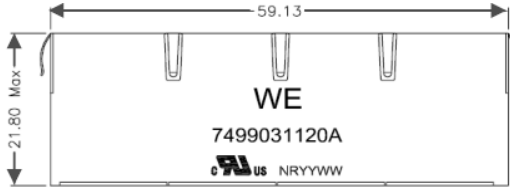
Affected P/N: 7499031001A	
Before Correction	After Correction
	
	
	
	

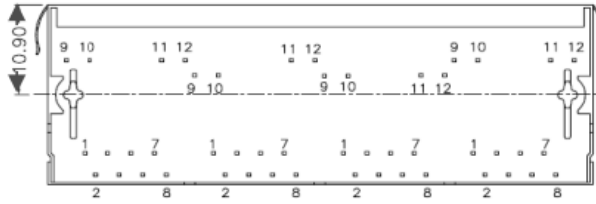
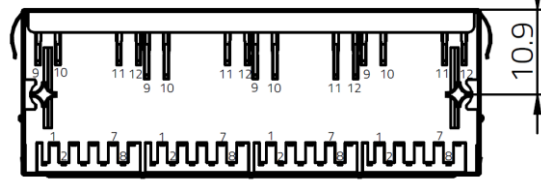
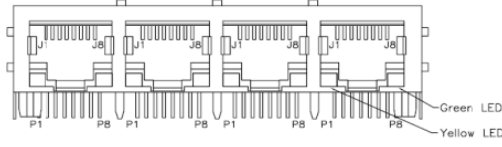
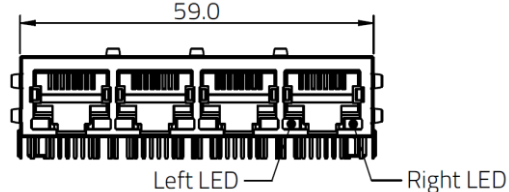
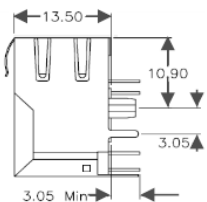
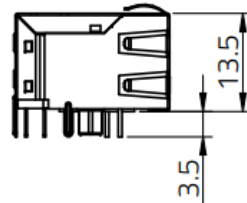
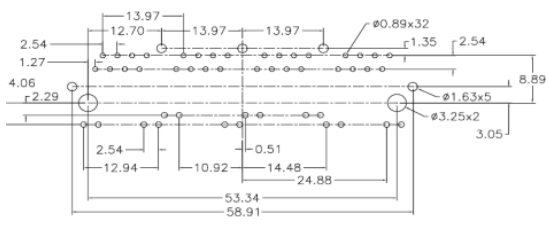
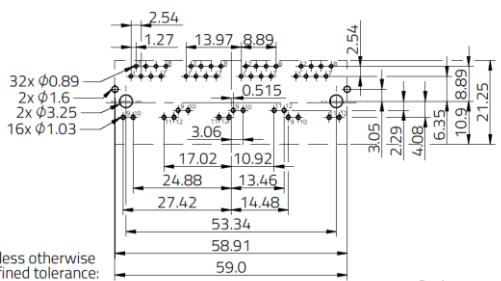

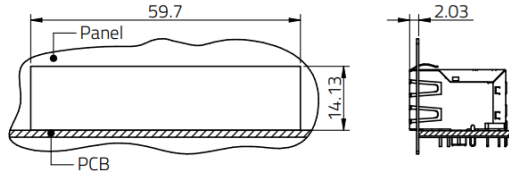
 <p>Recommended PCB layout (Component Side View) All dimension tolerance are ± 0.08 unless otherwise specified</p>	 <p>Unless otherwise defined tolerance: $\pm 0,10\text{mm}$ Scale - 1:1.25</p>
 <p>SUGGESTED PANEL CUTOUT</p>	
<p>Return Loss: 1-30 MHz 30-45 MHz 45-60 MHz 60-80 MHz</p>	<p>Return Loss: 1-30 MHz 30-60 MHz 60-80 MHz 80-100 MHz</p>
<p>Common Mode Rejection: 1-100 MHz</p>	<p>Common Mode Rejection: 1-30 MHz 30-60 MHz 60-100 MHz</p>
<p>Crosstalk: 1-100 MHz</p>	<p>Crosstalk: 1-60 MHz 60-100 MHz</p>
<p>HIPOT: 1500 Vrms 1min.</p>	<p>HIPOT: 2250 VDC 1min.</p>

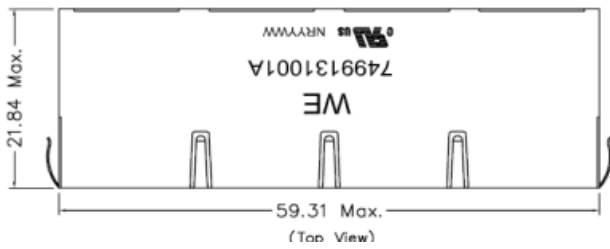
Affected P/N: 7499031120A	
Before Correction	After Correction
	
	
	
	
 <p>RECOMMENDED P.C.PATTERN, COMPONENT SIDE</p>	 <p>Unless otherwise defined tolerance: ±0.10mm Scale - 1:1.25</p>

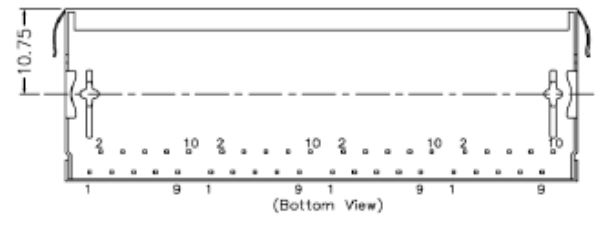
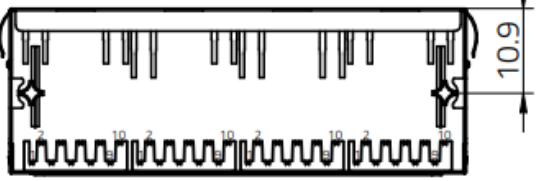
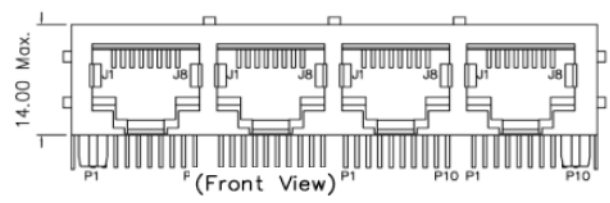
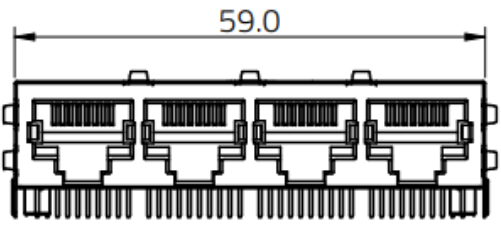
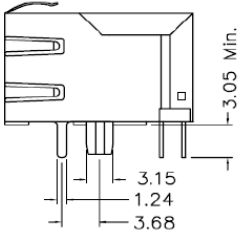
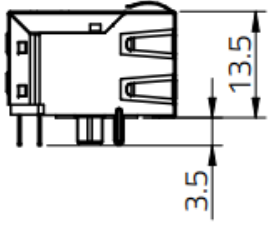
<p>No Panel Cutout</p>	 <p>Unless otherwise defined tolerance: $\pm 0,10\text{mm}$ Scale - 1:1,25</p>
<p>Return Loss: 1-10 MHz 10-30 MHz 45-60 MHz 60-80 MHz</p>	<p>Return Loss: 1-30 MHz 30-60 MHz 60-80 MHz 80-100 MHz</p>
<p>Common Mode Rejection: 1-50 MHz 50-150 MHz</p>	<p>Common Mode Rejection: 1-30 MHz 30-60 MHz 60-100 MHz</p>
<p>Crosstalk: 1-100 MHz</p>	<p>Crosstalk: 1-60 MHz 60-100 MHz</p>

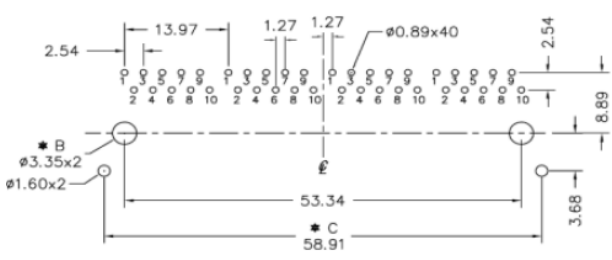
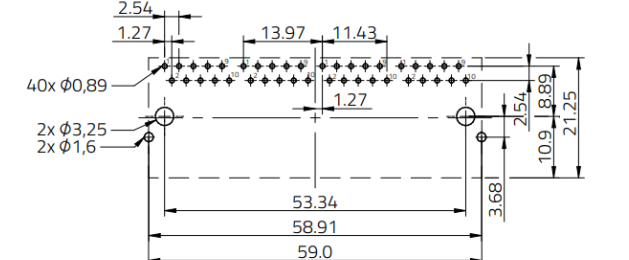
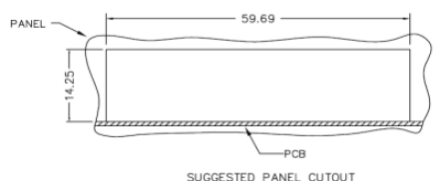
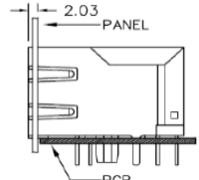
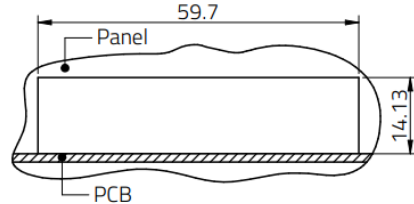
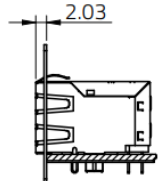
Affected P/N: 7499131001A	
Before Correction	After Correction
 <p>(Top View)</p>	
 <p>(Bottom View)</p>	
 <p>(Front View)</p>	
	

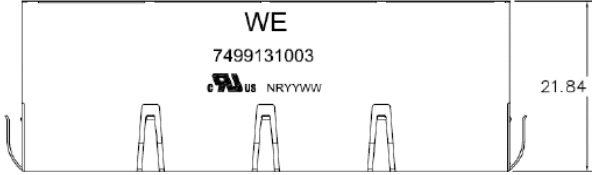
 <p>Recommended PCB layout (Component Side View) All dimension tolerance are ± 0.08 unless otherwise specified</p>	 <p>Unless otherwise defined tolerance: ± 0.10mm Scale - 1:1,25</p>
 <p>SUGGESTED PANEL CUTOUT</p> 	 
<p>Insertion Loss: 0,3-100 MHz</p>	<p>Insertion Loss: 1-100 MHz</p>
<p>Return Loss: 1-30 MHz 30-45 MHz 45-60 MHz 60-80 MHz</p>	<p>Return Loss: 1-30 MHz 30-60 MHz 60-80 MHz 80-100 MHz</p>
<p>Common Mode Rejection: 1-100 MHz -> -35 dB</p>	<p>Common Mode Rejection: 1-30 MHz -> -30 dB 30-60 MHz -> -30 dB 60-100 MHz -> -30 dB</p>
<p>Crosstalk: 1-100 MHz</p>	<p>Crosstalk: 1-60 MHz 60-100 MHz</p>
<p>HIPOT: 1500 Vrms 1min.</p>	<p>HIPOT: 2250 VDC 1min.</p>

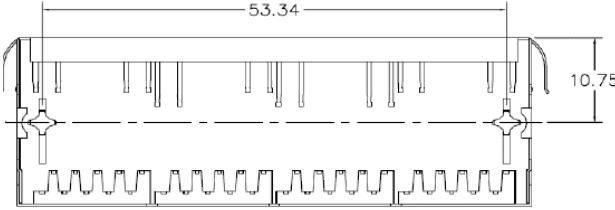
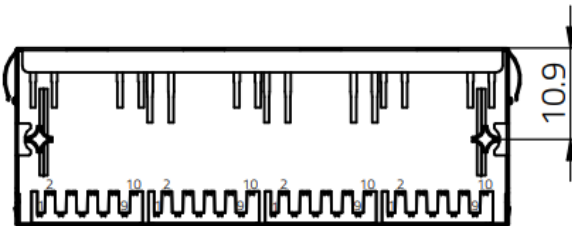
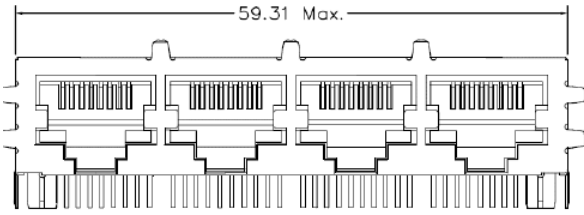
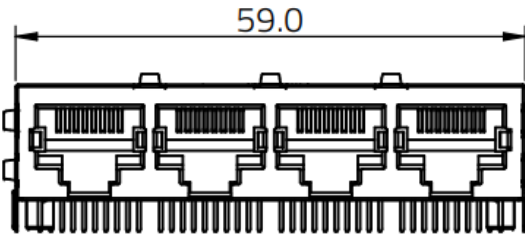
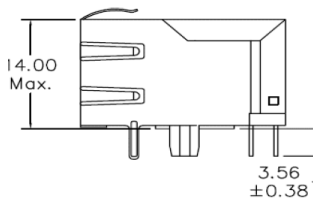
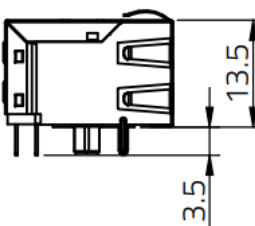
Affected P/N: 7499131003	
Before Correction	After Correction
	
	
	
	

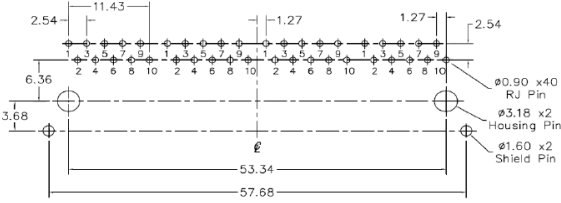
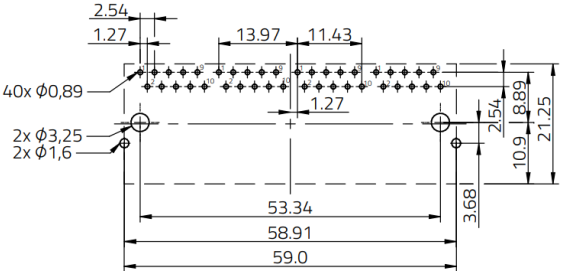
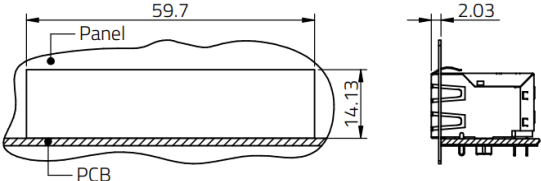
 <p>Recommended PCB layout (Component Side View) All dimension tolerance are ± 0.08 unless otherwise specified</p>	 <p>Unless otherwise defined tolerance: $\pm 0,10\text{mm}$ Scale - 1:1,25</p>
<p>No Panel cutout</p>	
<p>Return Loss: 1-30 MHz 30-45 MHz 45-60 MHz 60-80 MHz</p>	<p>Return Loss: 1-30 MHz 30-60 MHz 60-80 MHz 80-100 MHz</p>
<p>Common Mode Rejection: 1-100 MHz</p>	<p>Common Mode Rejection: 1-30 MHz 30-60 MHz 60-100 MHz</p>
<p>Crosstalk: 1-100 MHz</p>	<p>Crosstalk: 1-60 MHz 60-100 MHz</p>
<p>HIPOT: 1500 Vrms 1min.</p>	<p>HIPOT: 2250 VDC 1min.</p>

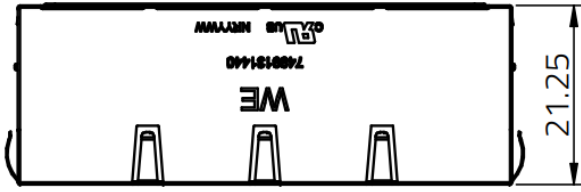
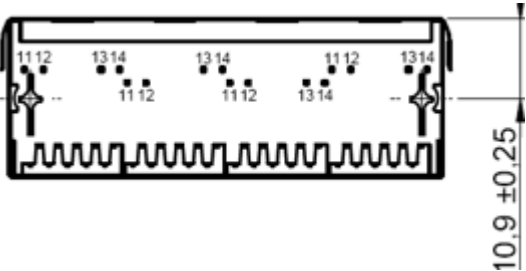
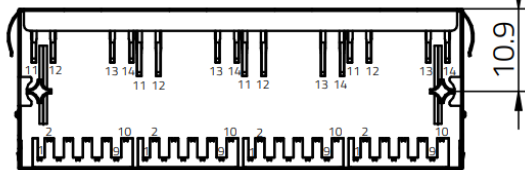
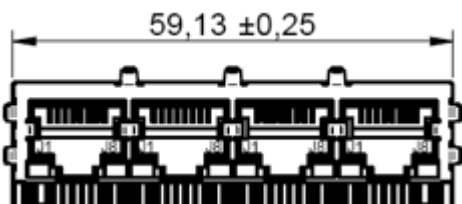
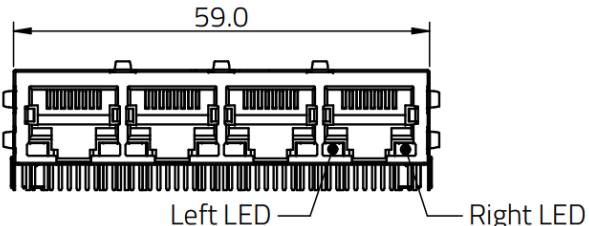
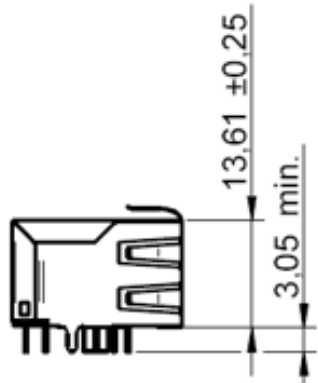
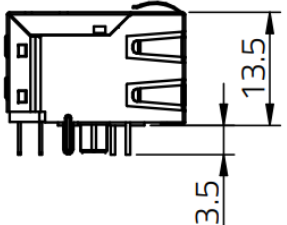
Affected P/N: S20100136	
Before Correction	After Correction
	
	
	
	

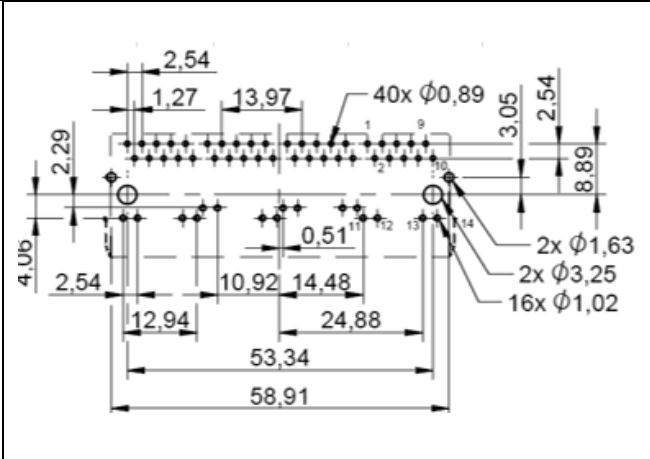
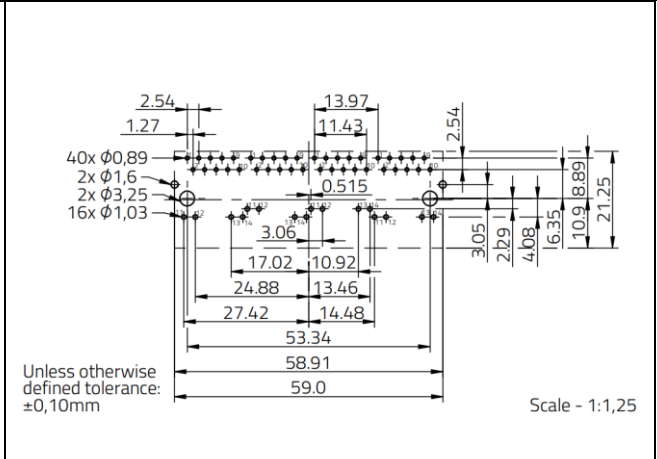
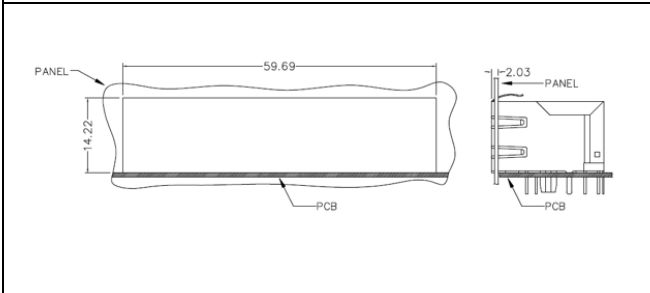
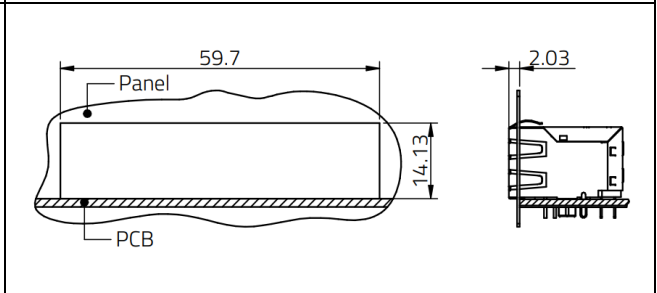
	 <p>Unless otherwise defined tolerance: ±0,10mm</p> <p>Scale - 1:1,25</p>
	
<p>Common Mode Rejection: 1-100 MHz</p>	<p>Common Mode Rejection: 1-30 MHz 30-60 MHz 60-100 MHz</p>



RELIABILITY / QUALIFICATION OF CHANGE:

An additional reliability testing was performed and approved.

Additional details of the tests can be found in the table below:

Test Item	Sample size	Reference	Test conditions	Acceptance
Resistance to Soldering Heat (THT Types)	30	MIL-STD-202-210	T _p = 260 ±5 °C, t _p = 10 ±1 s, 1 time wave	Approved
Soldering Test (THT Types)	30	J-STD-002	Steam Aging 8 hrs @ 93 °C, Soldering Temperature: 245 ±5 °C Soldering Time: 4 ~ 5 seconds Solder: Sn96.5Ag3Cu0.5	Approved
OCL at temperature limits	10	eiSos PM Standard	Put in oven while measuring the inductance. (OCL value at 1. Ambient Temperature, 2. Low temperature limit, 3. High temperature limit) Operating temp. limits ±3 °C Electrical conditions: 100 mV, 100 kHz, Bias current see datasheet Temperature limits: See datasheet	Approved
High Temperature Exposure	30	MIL-STD-202-108	Temperature: 85 ±3 °C, Duration: 500 hours	Approved
Low Temperature Storage life	30	JESD22-A119	Temperature: -40 ±3 °C, Duration: 500 hours	Approved
Thermal Shock	30	MIL-STD-202-107	-40 °C (30min) ~ 85 °C (30min), Transfer time max. 20s, 300 cycles	Approved
Vibration	30	MIL-STD-202-204	10g's for 20 minutes, 12 cycles each of 3 orientations. Test from 15-2000 Hz	Approved
MaU WES 3.1 Mating & unmating (force)	5	EIA-364-13D	Test speed: 25mm/min, maximal force value while mating and unmating.	Approved

See next page



Durability	5	IEC 60512, Test 9a, 13b /EIA -364-09C	Mate and Unmate connector, 30Nmax, Test speed = 450~550 cycles/hour, total 1200 cycles.	Approved
Moisture Resistance	30	MIL-STD-202-106	Temperature: 25 °C ~ 65 °C, 24H/cycle humidity: 95 % (R.H), Duration: 500 hours	Approved
Static Pull	5	EIA-364-98	53.4 N (12 lbf) min pull at an 40° angle, 4 directions, electrical load:100 mA DC; 60 s in each direction.	Approved
Dynamic Pull	5	EIA-364-41E	33.34 N (7.5 lbf) min pull at an 40° angle from normal hanging axis, each of 2 planes dimension, electrical load:100 mA DC; 4 cycles a minute, 3 cycles (full rotations in each direction)	Approved
Salt Spray	30	EIA-364-26B	Temperature: 35±2 °C, humidity: 95 ~ 98 % (R.H) PH Value: 6.5 ~ 7.2, Duration time: 72 hours Density of salt water: 5 ±1 %	Approved