



ON Semiconductor®

# ON Semiconductor DATA SHEET

## EFC4615R — N-Channel Silicon MOSFET General-Purpose Switching Device Applications

### Features

- 2.5V drive
- Best suited for LiB charging and discharging switch
- Common-drain type

### Specifications

Absolute Maximum Ratings at Ta=25°C

| Parameter                | Symbol           | Conditions   | Ratings     | Unit |
|--------------------------|------------------|--|-------------|------|
| Source-to-Source Voltage | V <sub>SSS</sub> |  | 24          | V    |
| Gate-to-Source Voltage   | V <sub>GSS</sub> |  | ±12         | V    |
| Source Current (DC)      | I <sub>S</sub>   |  | 6           | A    |
| Source Current (Pulse)   | I <sub>SP</sub>  | PW≤10 μs, duty cycle≤1%  | 60          | A    |
| Total Dissipation        | P <sub>T</sub>   | When mounted on ceramic substrate (5000mm <sup>2</sup> ×0.8mm) | 1.6         | W    |
| Channel Temperature      | T <sub>ch</sub>  |  | 150         | °C   |
| Storage Temperature      | T <sub>stg</sub> |  | -55 to +150 | °C   |

### Package Dimensions

unit : mm (typ)  
7067-001

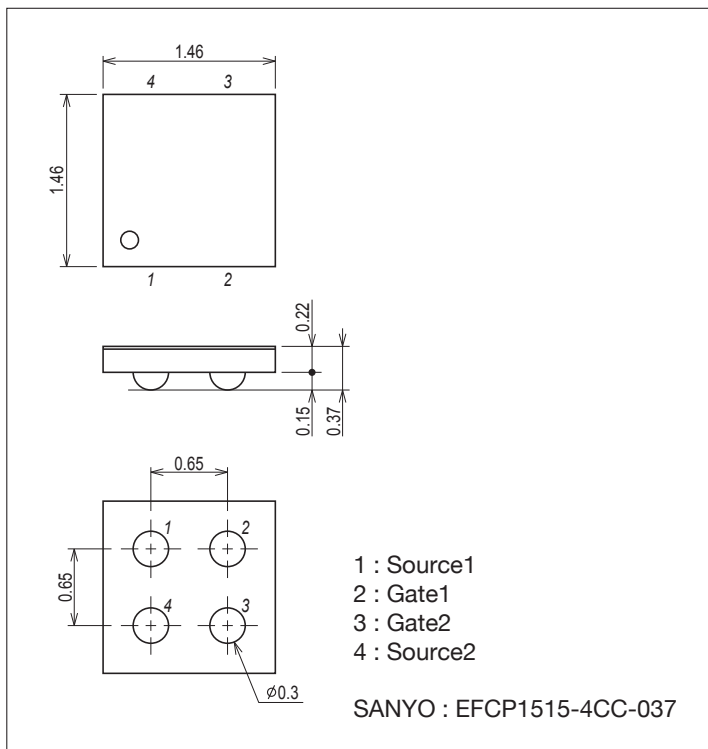

### Product & Package Information

- Package : EFCP
- JEITA, JEDEC : -
- Minimum Packing Quantity : 5,000 pcs./reel

### Taping Type : TR

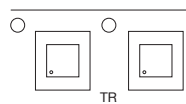

### Marking

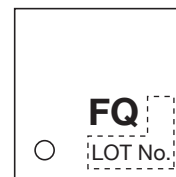

### Electrical Connection

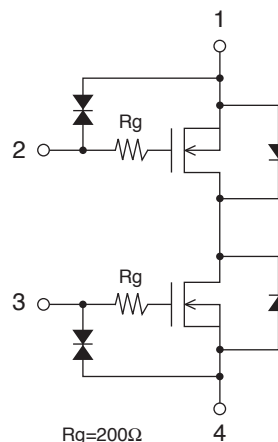

# EFC4615R

## Electrical Characteristics at Ta=25°C

| Parameter                                   | Symbol        | Conditions                                 | Ratings |     |          | Unit       |
|---|---------------|--|---------|-----|----------|------------|
|   |               |  | min     | typ | max      |            |
| Source-to-Source Breakdown Voltage          | $V_{(BR)SSS}$ | $I_S=1mA, V_{GS}=0V$ Test Circuit 1        | 24      |     |          | V          |
| Zero-Gate Voltage Source Current            | $I_{SSS}$     | $V_{SS}=20V, V_{GS}=0V$ Test Circuit 1     |         |     | 1        | A          |
| Gate-to-Source Leakage Current              | $I_{GSS}$     | $V_{GS}=\pm 8V, V_{SS}=0V$ Test Circuit 2  |         |     | $\pm 10$ | A          |
| Cutoff Voltage                              | $V_{GS(off)}$ | $V_{SS}=10V, I_S=1mA$ Test Circuit 3       | 0.5     |     | 1.3      | V          |
| Forward Transfer Admittance                 | $ y_{fs} $    | $V_{SS}=10V, I_S=3A$ Test Circuit 4        |         | 5.4 |          | S          |
| Static Source-to-Source On-State Resistance | $R_{SS(on)1}$ | $I_S=3A, V_{GS}=4.5V$ Test Circuit 5       | 19      | 27  | 31       | m $\Omega$ |
|   | $R_{SS(on)2}$ | $I_S=3A, V_{GS}=4.0V$ Test Circuit 5       | 21      | 28  | 33       | m $\Omega$ |
|   | $R_{SS(on)3}$ | $I_S=3A, V_{GS}=3.1V$ Test Circuit 5       | 24      | 33  | 44       | m $\Omega$ |
|   | $R_{SS(on)4}$ | $I_S=3A, V_{GS}=2.5V$ Test Circuit 5       | 28      | 39  | 52       | m $\Omega$ |
| Turn-ON Delay Time                          | $t_{d(on)}$   | See specified Test Circuit. Test Circuit 7 |         | 13  |          | ns         |
| Rise Time                                   | $t_r$         | See specified Test Circuit. Test Circuit 7 |         | 235 |          | ns         |
| Turn-OFF Delay Time                         | $t_{d(off)}$  | See specified Test Circuit. Test Circuit 7 |         | 335 |          | ns         |
| Fall Time                                   | $t_f$         | See specified Test Circuit. Test Circuit 7 |         | 360 |          | ns         |
| Total Gate Charge                           | $Q_g$         | $V_{SS}=10V, V_{GS}=4.5V, I_S=6A$          |         | 8.8 |          | nC         |
| Forward Source-to-Source Voltage            | $V_{F(S-S)}$  | $I_S=6A, V_{GS}=0V$ Test Circuit 6         |         | 1   | 1.2      | V          |

### Test circuits are example of measuring FET1 side

Test Circuit 1  
 $V_{SSS} / I_{SSS}$

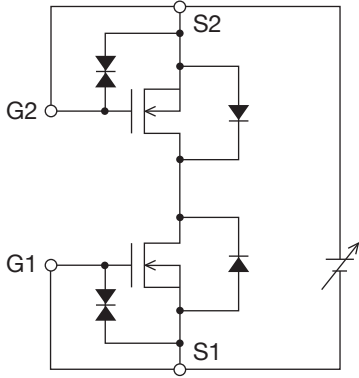

IT11565

Test Circuit 2  
 $I_{GSS(+)} / (-)$

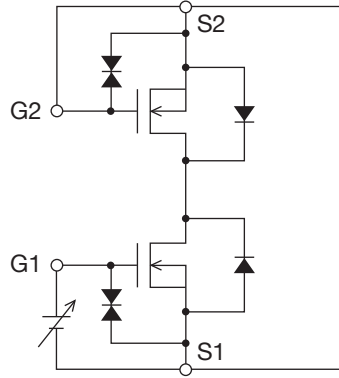

IT11566

Test Circuit 3  
 $V_{GS(off)}$

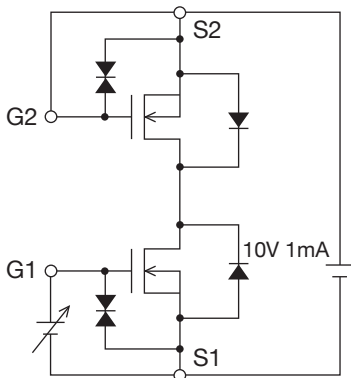

IT11567

Test Circuit 4  
 $|y_{fs}|$

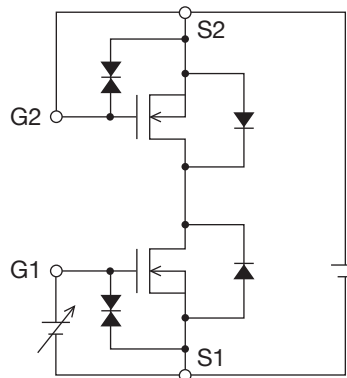

IT11568

\* Note: Connect the measurement terminal reversely if you want to measure the FET2 side.

Test Circuit 5  
RSS(on)

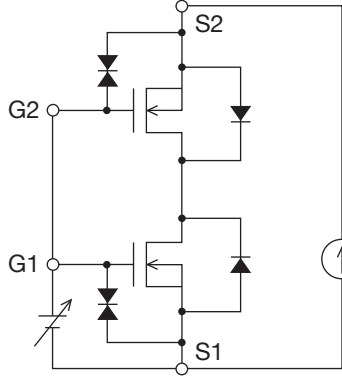

IT11569

Test Circuit 6  
VF(S-S)

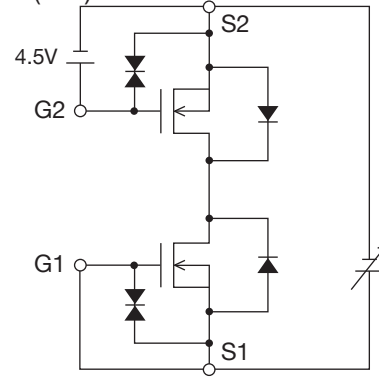

IT11570

Test Circuit 7  
td(on), tr, td(off), tf

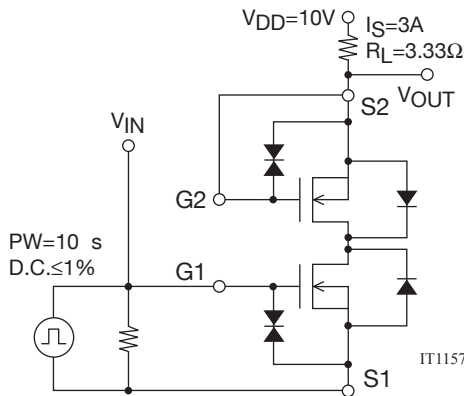

IT11571

Test Circuit 8  
Qg

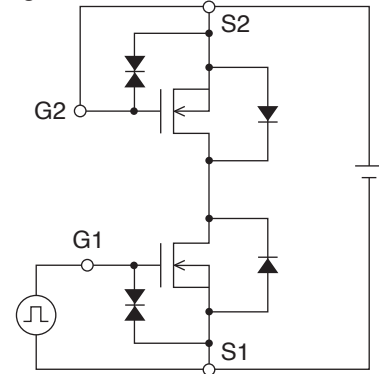

IT15409

\* Note: Connect the measurement terminal reversely if you want to measure the FET2 side.

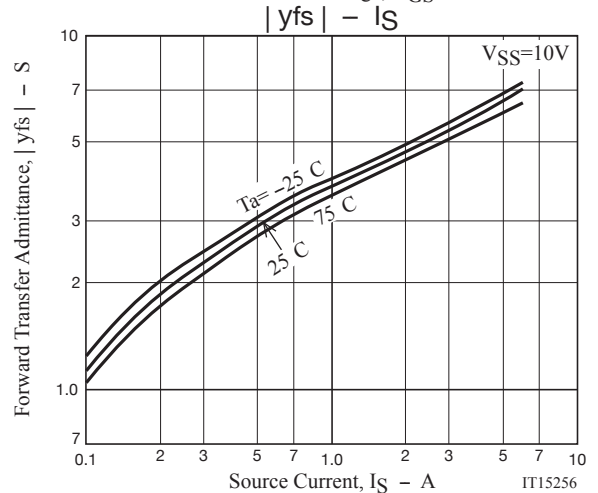
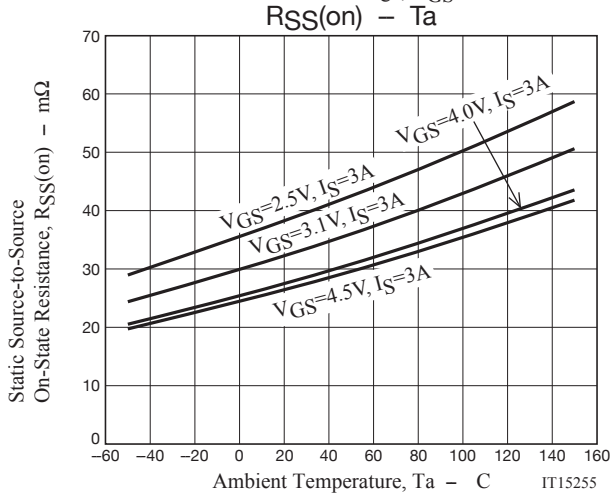
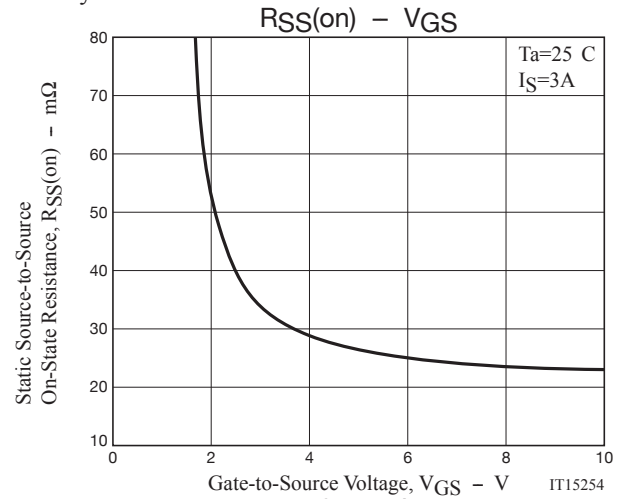
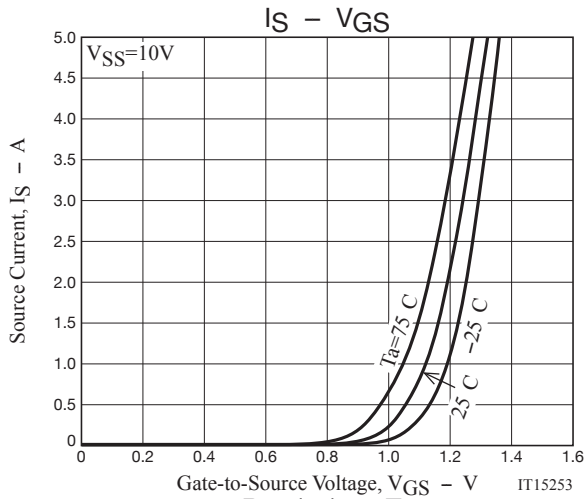

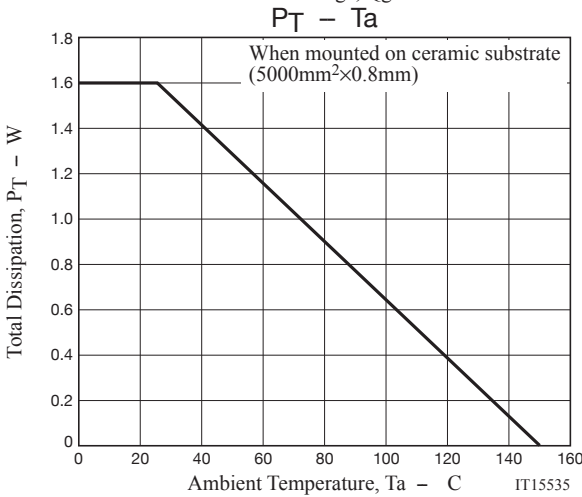
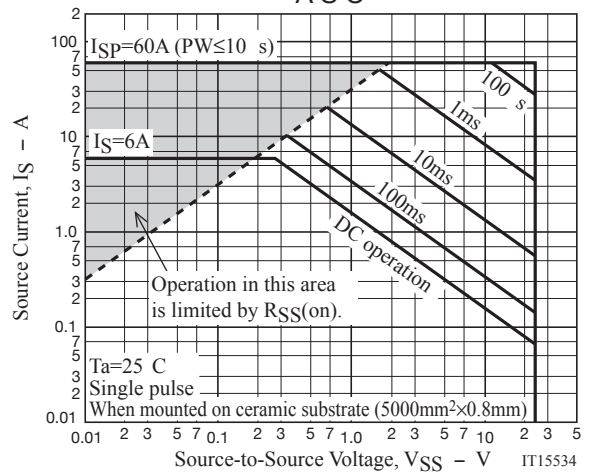
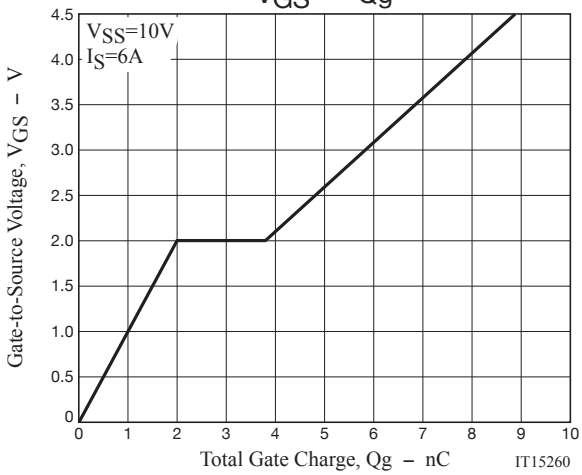
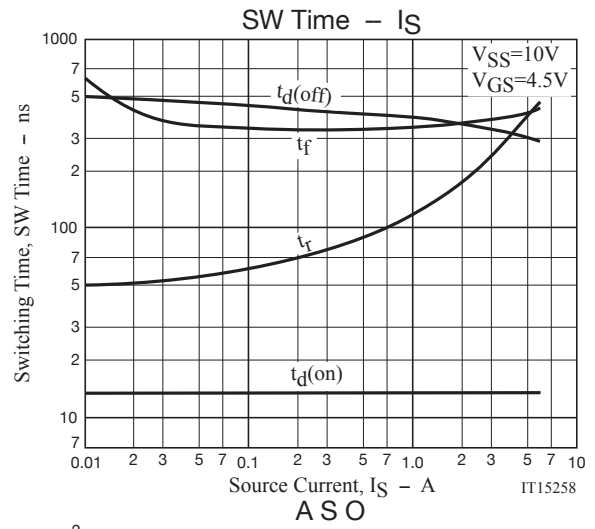
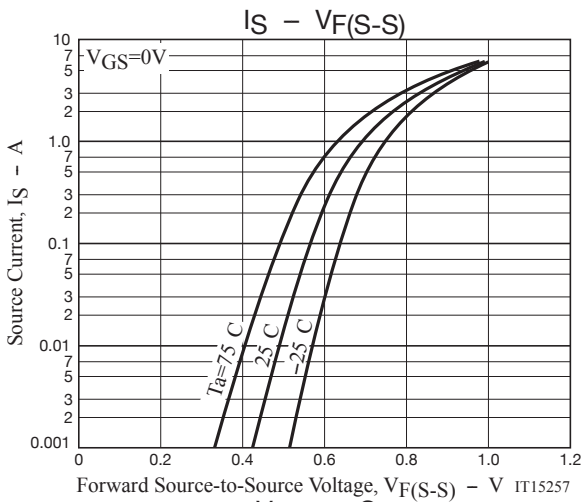

ON Semiconductor and the ON logo are registered trademarks of Semiconductor Components Industries, LLC (SCILLC). SCILLC reserves the right to make changes without further notice to any products herein. SCILLC makes no warranty, representation or guarantee regarding the suitability of its products for any particular purpose, nor does SCILLC assume any liability arising out of the application or use of any product or circuit, and specifically disclaims any and all liability, including without limitation special, consequential or incidental damages. SCILLC strives to supply high-quality high-reliability products and recommends adopting safety measures when designing equipment to avoid accidents or malfunctions. Such measures include but are not limited to protective circuits and error prevention circuits for safe design, redundant design, and structural design. "Typical" parameters which may be provided in SCILLC data sheets and/or specifications can and do vary in different applications and actual performance may vary over time. All operating parameters, including "Typicals," must be validated for each customer application by customer's technical experts. SCILLC shall not be held liable for any claim or suits with regard to a third party's intellectual property rights which has resulted from the use of the technical information and products mentioned above. SCILLC does not convey any license under its patent rights nor the rights of others. SCILLC products are not designed, intended, or authorized for use as components in systems intended for surgical implant into the body, or other applications intended to support or sustain life, or for any other application in which the failure of the SCILLC product could create a situation where personal injury or death may occur. Should Buyer purchase or use SCILLC products for any such unintended or unauthorized application, Buyer shall indemnify and hold SCILLC and its officers, employees, subsidiaries, affiliates, and distributors harmless against all claims, costs, damages, and expenses, and reasonable attorney fees arising out of, directly or indirectly, any claim of personal injury or death associated with such unintended or unauthorized use, even if such claim alleges that SCILLC was negligent regarding the design or manufacture of the part. SCILLC is an Equal Opportunity/Affirmative Action Employer. This literature is subject to all applicable copyright laws and is not for resale in any manner.

**PUBLICATION ORDERING INFORMATION**

**LITERATURE FULFILLMENT:**

Literature Distribution Center for ON Semiconductor  
 P.O. Box 5163, Denver, Colorado 80217 USA  
 Phone: 303-675-2175 or 800-344-3860 Toll Free USA/Canada  
 Fax: 303-675-2176 or 800-344-3867 Toll Free USA/Canada  
 Email: orderlit@onsemi.com

**N. American Technical Support:** 800-282-9855 Toll Free  
 USA/Canada.

**Europe, Middle East and Africa Technical Support:**  
 Phone: 421 33 790 2910

**Japan Customer Focus Center**  
 Phone: 81-3-5773-3850

**ON Semiconductor Website:** www.onsemi.com

**Order Literature:** http://www.onsemi.com/orderlit

For additional information, please contact your local  
 Sales Representative