

# Spherical roller bearings, cylindrical and tapered bore

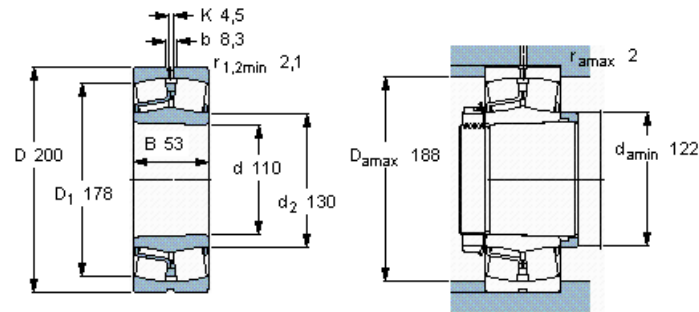

Principal dimensions			Basic load ratings		Fatigue load limit $P_u$	Speed ratings		Mass	Designation
d	D	B	dynamic	static		Reference speed	Limiting speed		
mm			C	$C_0$	kN	r/min	kg	-	* - SKF Explorer bearing
110	200	53	560	640	63	3000	6,85	22222 EK *	



Tapered bore, taper  
1: 12

### Calculation factors

- e 0,25
- $Y_1$  2,7
- $Y_2$  4
- $Y_0$  2,5