

543942 DGSL-10-10-PA Mini slide - Series till 07-2022

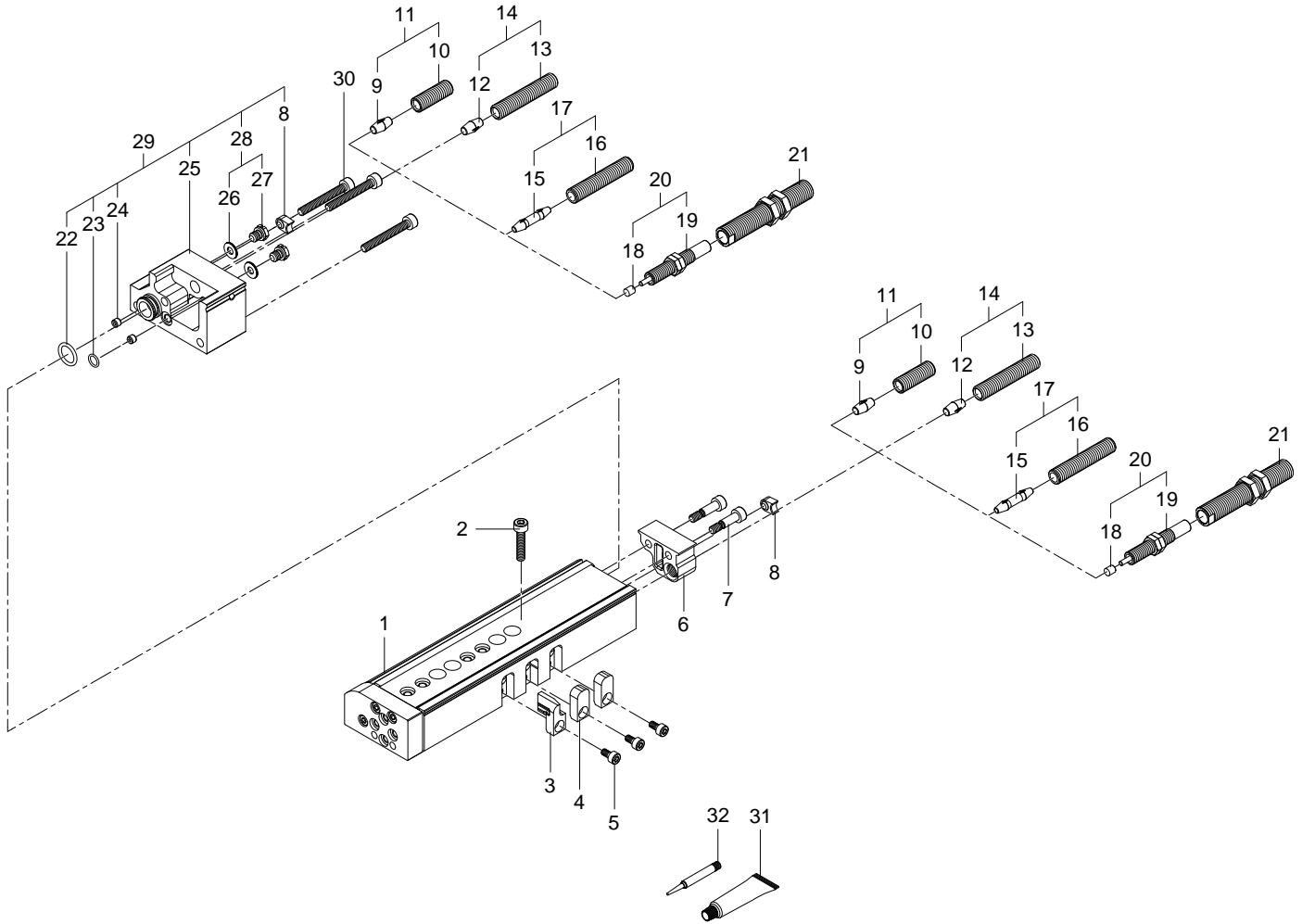

543942 DGSL-10-10-PA Mini slide - Series till 07-2022

Pos.	Part no.	Type	Note	Qty.	Unit
A	713746	DGSL-10-...- Set of wearing parts	Spare parts: 2, 9, 12, 15, 18, 22, 23, 26, 31, 32	1	PC
1		DGSL-10-10 Guide module	Not available	1	PC
2	205318	ISO 4762-M4X20-8.8 Socket head screw		1	PC
3	686785	DGSL-10 Stop		1	PC
4	686801	DGSL-10 Covering		2	PC
5	209537	ISO 4762-M4X8-8.8 Socket head screw	Tightening torque 2.9 Nm / 2.1 lbf ft	3	PC
6	8145936	DGSL-10 Moment compensator		1	PC
7		ISO 4762-M4X16-10.9 Socket head screw	Not available Tightening torque 3.2 Nm / 2.4 lbf ft	2	PC
8	699254	DGSL-10 Clamping component	Use locking compound. See position 32	2	PC
9	382090	5,9X7,1 Buffer element		2	PC
10		DYEF-S-M8-Y1 adjustment sleeve	Not available separately, see position 11	2	PC
11	1152536	DYEF-S-M8-Y1 Shock absorber	shock absorber -E	2	PC
12	382090	5,9X7,1 Buffer element		2	PC
13		DGSL-10-P adjustment sleeve	Not available separately, see position 14	2	PC
14	1179834	DYEF-M8-Y1 Shock absorber	shock absorber -P	2	PC
15	683973	DGSL-10-PFJ Buffer		2	PC
16		DGSL-10-P1 adjustment sleeve	Not available separately, see position 17	2	PC
17	548373	DYEF-M8-Y1F Shock absorber	shock absorber -P1	2	PC
18	707459	DYSC/W-4- Buffer		2	PC
19		YSRWF-4-6 Shock absorber	Not available separately, see position 20	2	PC
20	548070	DYSW-4-6-Y1F Shock absorber	Attention, please order position 21 as well shock absorber -Y11	2	PC
21	1165476	DAYH-4 reducing sleeve	Attention, please order position 20 as well shock absorber -Y11	2	PC
22		B-10X1-N-NBR75 O-ring ISO3601	Not available separately, see position A Grease using during assembly. See position 31	1	PC
23		B-6X1-N-NBR75 O-ring ISO3601	Not available separately, see position A Grease using during assembly. See position 31	1	PC
24		DGSL-10 Flow control plate	Not available separately, see position 29	2	PC
25		DGSL-10 Connection cap	Not available separately, see position 29	1	PC
26		OK-M5 Sealing ring	Not available separately, see position A	2	PC

Pos.	Part no.	Type	Note	Qty.	Unit
27		B-M5 B Plug screw	Not available separately, see position 28 Tightening torque 2 Nm / 1.5 lbf ft	2	PC
28	712005	B-M5-B-OK Blanking plug		2	PC
29	714230	DGSL-10-...-ET Connection cover module		1	PC
30	326601	ISO 4762-M3X30-8.8 Socket head screw	Tightening torque 1.3 Nm / 1.0 lbf ft Use locking compound. See position 32	3	PC
31	684474	LUB-KC1 SILIKONFREI 20ML Lubricating grease		1	PC
32	8181256	CYBERBOND TM44 TB1ML Adhesive bonding agent		1	PC